

Full Length Research Paper

A new gateway node for wireless sensor network applications

Murat DENER

Graduate School of Natural and Applied Sciences, Gazi University, 06500, Ankara, Turkey.

Received 30 June, 2015; Accepted 12 February, 2016

Wireless sensor network based applications have gained a significant importance in recent years. However, it creates problems when sending the detected data over distant stations even though establishment of sensor networks by means of ZigBee communication modules as the communication range of these modules are limited. For this reason, in this study, design of a gateway node which can be used in the sensor network applications was developed. The gateway node developed consists of a CC2530 ZigBee Module, an MSP430G2553 ultra low power microcontroller and a SIM900 GSM/GPRS module. As a result of this node, the sudden changes can be sent as data packets (SMS), also, the data can easily be monitored on web based and mobile platforms. It is anticipated that the study will be useful for the researchers conducting sensor network applications.

Key words: Wireless sensor networks, ZigBee, sensor node, gateway node.

INTRODUCTION

The wireless networks using sensors for monitoring physical or environmental conditions in diversified locations such as temperature, humidity, light, pressure, pollution, soil constituents, noise level, vibration and object movements in a cooperative way and containing devices working independently from each other are called "wireless sensor networks" (Akyildiz et al., 2002).

As for the nodes that are used in wireless sensor networks and that have the capabilities of calculation, perceptual data collection and communication with the other connected sensors in the network are called sensor nodes (Chong and Kumar, 2003).

Sensor nodes fundamentally consist of the main

constituents of a microcontroller, a transceiver, an external memory, a power source and a sensor (Gupta et al., 2013). The field of use of Wireless Sensor Networks increases each passing day. The Wireless Sensor Networks can be used in military applications containing guarding of battle grounds, monitoring of enemy movements, exploring of the land, tracking of military and personnel vehicles, monitoring of friendly forces and speeds and locations of the targets; in environmental applications containing forecasting of weather and air pollution, tracking of natural disasters such as flood, earthquake and forest fires, monitoring of agricultural activities and monitoring of animal farms; in medical

E-mail: muratdener@gazi.edu.tr.

Author(s) agree that this article remain permanently open access under the terms of the [Creative Commons Attribution License 4.0 International License](https://creativecommons.org/licenses/by/4.0/)

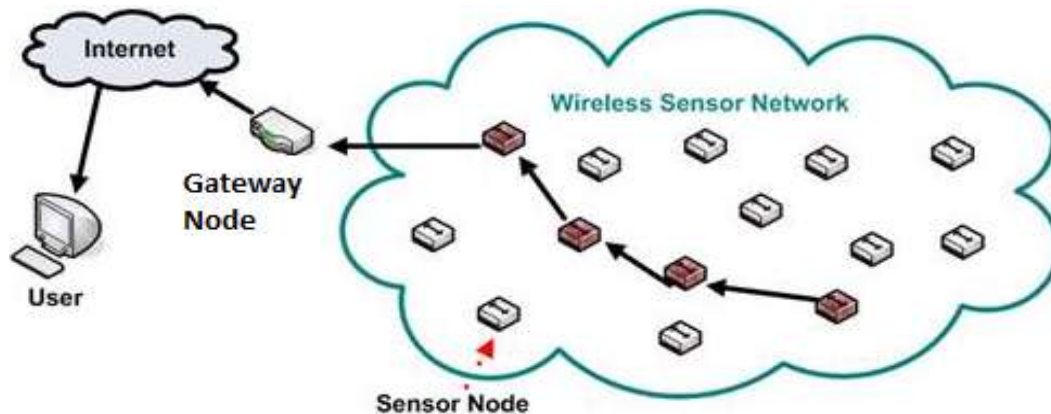

Figure 1. Wireless Sensor Network.

applications containing locating doctors in a hospital, monitoring of conditions of patients, guarding of the elderly and monitoring of various medical parameters; in commercial applications containing monitoring and locating vehicles, monitoring of power lines, tracking of young children by their parents, lighting control, control of traffic lights and fire systems; and in home automation applications containing smart home environments and building security systems (Carlos et al., 2007).

But, existing sensor nodes like TelosB, MicaZ, Mica2 etc, have no gateway node for sending information to distant stations. These nodes sense data and can send data only in a PC which is connected to a USB cable and to each other. For example, if you have a wireless sensor network in your farm, you can monitor obtained data with these nodes only in same farm. If you are in the home, this place is far from your farm, you cannot monitor the values. Therefore, these nodes cannot be used in many applications which require you to send your data to distant stations.

In this study, a gateway node was developed for ZigBee networks. Through the gateway node developed, the data detected from the sensor nodes in the medium can be sent to the distant stations with the help of GSM/GPRS technologies.

This rest of the paper is organized as follows. The general structure of the sensor networks is given in the 2nd part. In part 3, the related works are explained. While the hardware design of the sensor node developed is presented in part 4, the software design of the sensor node is presented in part 5. Testing and results are presented in part 6. The conclusions of the study are given in part 7.

OVERALL STRUCTURE OF WIRELESS SENSOR NETWORK SYSTEM

Wireless Sensor Networks consist of small-sized sensor nodes installed on the environment. These nodes carry,

by collaborating in a physical ground, what they learn from the physical world to the virtual world platform (Mayank, 2005). This is shown in Figure 1.

The data obtained from the physical environment by various sensors in sensor networks are wirelessly transferred onto their target data processing network by means of a collaboration method called from ear to ear. The gateway to the data processing network is called a gateway node. This node is a special node which is able to communication with the sensor nodes as well as with the communication network. The node is considered to be a static node with no energy issues and with a high calculation capability.

As for the sensor nodes, they are general units with limited energy and calculation capabilities that communicate through radio technology. These units are automatically placed and installed with a purpose to detect and monitor some conditions and phenomena in the detecting zone. The numbers can be from hundreds to thousands depending on the application. On Wireless Sensor Networks, the wireless communication between the sensor nodes in the environment is generally carried out via a ZigBee Module.

ZigBee (ZigBee Alliance, 2005) is a technology based on 802.15.4 standard that has been developed for Personal Area Networks consuming low power which is suitable for high level communication protocols. ZigBee is suitable for short ranged applications requiring low data transfer rates. ZigBee standard was designed for M2M applications and provides simple, secured communication means with low failure rate for M2M applications. As the data packet sizes, power consumption and complexity of technologies such as Wi-Fi and Bluetooth are too large, they are more prone to failures as compared to ZigBee networks. There are 3 tasks of devices in ZigBee networks.

1. Gateway: There is only one in a given network. It is responsible for the arrangement of the network structure of the network. Gateway needs to be started first in

ZigBee networks. It is the node in which memory, RAM and processing capacity features are the most advanced.

2. Router: It is responsible for relaying messages that have been sent to it to the other nodes (gateway or end devices) in the network. It does not process the data; it is just used as a router and for extending the range.

3. End device: It is installed on the sensors in the network and its task is to transfer the measurements it makes to the router or the gateway nodes.

As is known, the range of the sensor nodes in the ZigBee networks is limited. Thus, there is a limited communication range in ZigBee sensor networks. In the existing sensor nodes (TelosB, Mica2, MicaZ, etc.), the gateway node is formed by means of connecting it to a personal computer in the laboratory or the classroom and the applications are carried out this way. Therefore, the existing nodes are not usable in the applications containing hundreds of sensors distributed in the environment.

In this study, all issues were overcome and a new gateway node was developed for Wireless Sensor Networks.

RELATED WORKS

There are limited numbers of studies on gateway nodes that can be used for Wireless Sensor Networks. And most of the studies conducted consist of designs only. Yepeng et al. (2013) designed a gateway for the communication between ZigBee networks and the Internet in Smart Home technologies. They used an S3C2440 microprocessor, a JN5148 ZigBee module and a VT6656 as a WiFi Module. They converted the ZigBee Protocol data into WiFi protocol data. This way a gateway that can be used in a smart home technology was formed. Despite the fact that the node developed is used in smart homes, it cannot be used in different terrains where there would be no WiFi communication and other applications of the sensor networks. Thus, the scope of the study is limited.

Zhixiang and Jinxiang (2002) designed a gateway based on S3C2410 processor. They designed a new data sending protocol and degraded the differences between the ZigBee and the TCP/IP protocol; also, they designed a data sending management module. But the study conducted remained a theory. It was not put into implementation.

Zennaro et al. (2008) designed a new gateway node. They developed a prototype using development cards. Steenkamp et al. (2009) however, designed a gateway node on TinyOS using AT91RM9200 ARM development cards. The disadvantages of this study are that they use development cards. Wang et al. (2014) designed a gateway node using ZigBee and GPRS technologies. They used ARM S3C2440 as a processor. Song et al. (2008) designed a gateway node based on PXA270 processor using Linux. Wang et al. (2009) designed a ZigBee technology based gateway node using web

services. The node designed is for home or building automation applications. Sunitha et al. (2013) designed a ZigBee WiFi gateway node based on ARM7 LPC2148, ARM9 S3C2440 and embedded WiFi module. He et al. (2009) designed a ZigBee and GPRS technology based gateway node. They used S3C2410 processor. Manukonda and Nakkala (2009) designed a gateway node based on STM32W108 radio chip and embedded WiFi. All these studies consist of designs only.

However, in this study, a gateway node having a GSM and GPRS infrastructure which can be used with the existing sensor nodes was developed.

HARDWARE DESIGN

The gateway node is intended for reaching out to the sensor nodes available in the medium through distant stations and to control them. In the design of the sensor node CC2530 ZigBee module and MSP430G2553 processor was used. RXD, TXD and GND connections are established between the sensor node and the SIM900 GSM/GPRS node and the gateway node is thus obtained. The circuit diagram of the sensor node and SIM900 GSM/GPRS node is given in Figures 2 and 3.

The GSM/GPRS module is connected to the UART pin of the microcontroller through the pin J2. Thus, the communication of the GSM/GPRS module with the sensor node through serial communication protocol UART at 9600 baud speed will be established. The gateway node possesses all the features the sensor node possess. In addition to the codes of the sensor node codes for communicating with the GSM/GPRS module is added and sending of the data over the distant stations can be established.

The gateway node consists of four units: the power unit, transceiver, processing unit and GSM/GPRS Modem.

Power unit

The gateway node was designed in a way to be fed through a 12V/1A Adaptor. The feeding unit contains transformers for 4.2 V max. 2A GSM voltage and 3.3 V 100 mA RF unit voltage needed for 12 V entrance voltage. LM2576 Series, SIMPLE SWITCHER 3A Step-Down voltage regulator was used for 12 – 4.3 V transformer. Working with a 52 kHz Internal Fixed Frequency oscillator high level voltage regulation was obtained. LM1117-3.3 800 mA Low-Dropout Linear Regulator numbered LM1 was used for 4.2 – 3.3 V transformer. The feeding of the medium node connected is obtained through J3 terminal.

Transceiver

RF unit was designed in IEEE 802.15.4 standard used for personal domain networks using small low-power digital radio to support the typical networks such as wireless star topology and tree topology and the general mesh networks. Data security was aimed to be established by customising with high level communication protocols. The 3.3 V supply voltage is provided by LM1117-3.3 800 mA Low-Dropout Linear Regulator numbered LM1. In the RF unit of the gateway node IEEE 802.15.4 CC2530 ZigBee module was used. The working frequency is 2.4 GHz. The data transmission rate varies between 20 and 900 kilobit/second. The active running is 28 mA in RX mode, 68 mA in TX mode and varies between 1 and 200 μ A in Sleep Mode. It completes its transition from sleep mode to active mode in just 30 ms. The task of the RF unit is to transmit

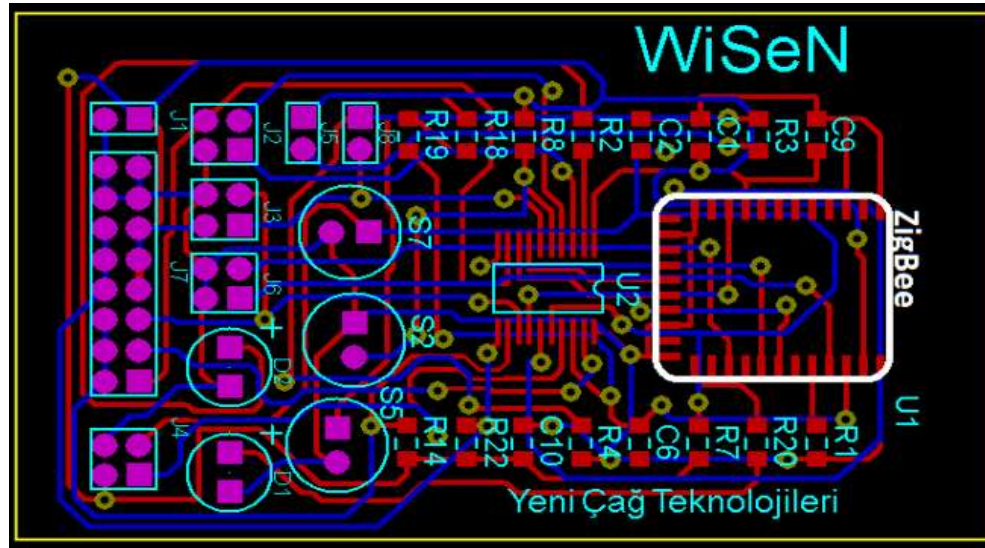

Figure 2. Sensor node.

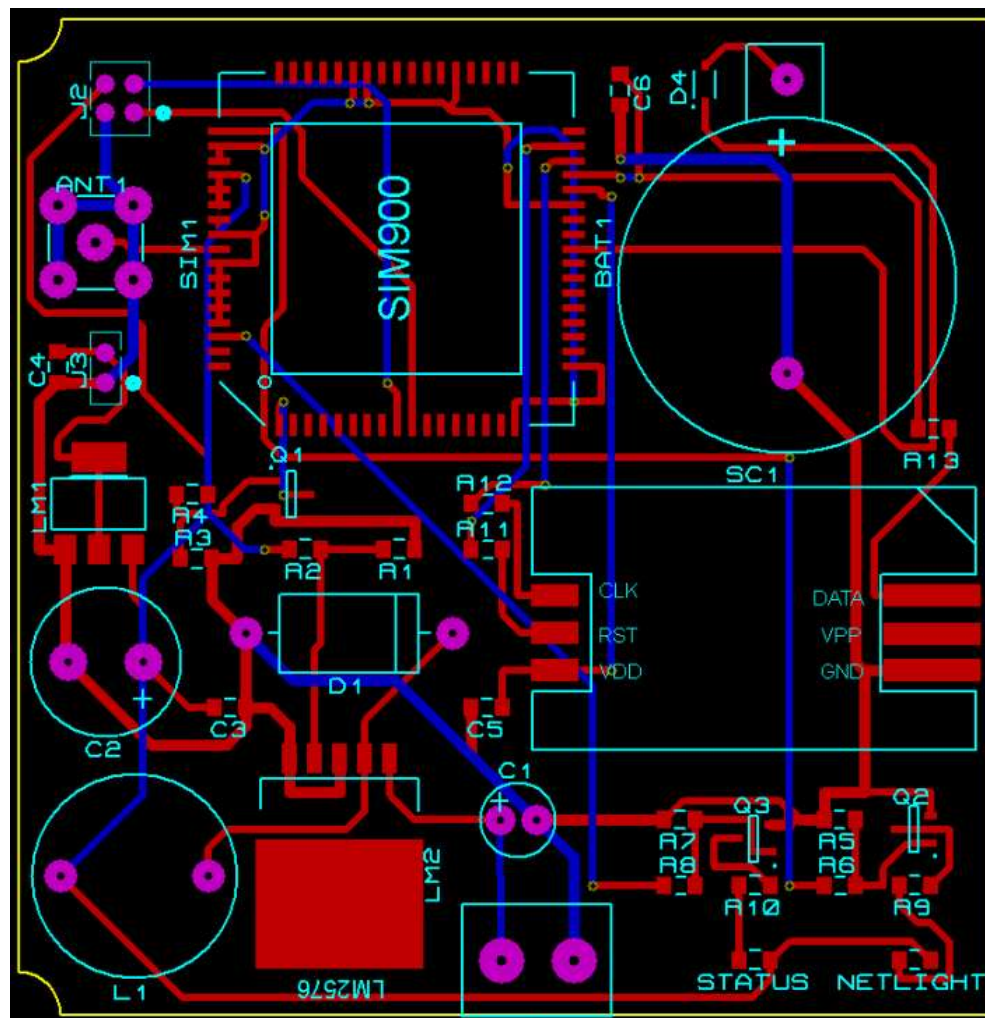

Figure 3. SIM900 GSM/GPRS node.

the data it collects from the sensor nodes in the environment over the network structure through the Serial UART module to the GSM/GPRS unit at a speed of 9600 baud from the J2 connector.

Processing unit

As it is known, the microcontrollers are micro-computers containing a microprocessor, a data and program memory, digital (Logical) inputs and outputs (I/O), analogue entries and other peripherals that add more power and functionality such as timers, counters, switches, analogue-to-digital converters put together on a single silicon chip. On the node, the MSP430G2553 model of the Texas Instruments company was used. The 3.3 V supply voltage is provided by LM1117-3.3 800 mA Low-Dropout Linear Regulator numbered LM1 on the circuit. Its task is to provide the coordinated working between the RF unit and the GSM/GPRS unit and to provide the transfer outside the sensor data it receives from the RF unit by means of the GSM/GPRS modem.

GSM/GPRS modem

SIM900 GSM/GPRS module of SIMCom Company in Quad-Band 850, 900, 1800, 1900 MHz frequency at 1 W 1800/1900 MHz power was used. There is one SIM card connection. The supply voltage of Max. 2A, in the range of 3,4 V to 4,5V is provided by the SIMPLE LM2576 series SWITCHER 3A Step-Down Voltage regulator as nominal 4.2 V 3A. Its task however, is to collect the data accumulated in the network structure in the central server via mobile data transfer over the Internet, in other words, it is the door of the sensor networks opening outwards.

Operation

Out of the 12 V, 1 A, 12 W input voltage 4 V SIM900 supply voltage is formed by SIMPLE SWITCHER 3A Step-Down Voltage Regulator. And gateway node voltage is formed by LM1117-3.3 800 mA Low-Dropout Linear Regulator. Through J1 terminal voltage is sent to the gateway node, and through J2 terminal serial data transfer is carried out at a speed of 9600 baud and the GSM and GPRS functions are conducted by means of AT commands. The on/off signal sent is strengthened over R4, R3 and Q1 by the MSP-PWRKEY pin and applied on the SIM900 Power Key input. CR2032 was used for the battery and the 1N4148 as well as the SIM900 memory. As for the StatusLED; the signal for turning on LED sent from the SIM900 is strengthened by the members R8, R7 and Q3 and the Status LED is turned on with the R10 current-limiting resistor. For NetLightLED, the signal for turning on the LED sent from the SIM900 is strengthened by the members R6, R5 and Q2 and the NetLight LED is turned on with the R9 current-limiting resistor. The SIM card of the relevant GSM operator is inserted into the SIM card slot connected into the circuit in order to establish communication in 800-900 and 1800-1900 MHz network frequencies. The circuit diagram of the SIM900 GSM/GPRS node is given in Figure 4. The gateway node designed can be used with other sensor nodes by means of connecting relevant ends into the SIM900 GSM/GPRS module.

SOFTWARE DESIGN

The software was developed in Code Composer Studio provided freely by the Texas Instrument company. The data coming from the sensor nodes in the environment arrive at the CC2530 ZigBee module available in the gateway node. The data arrived is processed by the MSP430 processor and sent to the GSM/GPRS

module. The MSP430 being used as a microcontroller communicates with the CC2530 ZigBee module being used as a transceiver over SPI line. It communicates with the GSM/GPRS module over the UART line. There are 2 conditions on the data coming to this GSM/GPRS module:

1. For standard applications where there is no threshold value, the data is directly saved on the database.
2. For critical application where there is a threshold value however, the data is saved on the data base as well as transactions such as sending a message/making a call to the registered numbers are performed. These situations are described in Figure 5.

PostgreSQL was used as the database. The data that come to the database however, can be transiently monitored and tracked over the web or mobile based application in real time. This was described in Figure 6. Data limitation on the general protocol run on ZigBee networks is shown in Table 1.

Due to the fact that the gateway node developed is programmable, this packet structure can be customised. The network table created by the network addresses assigned to the devices in the ZigBee network is given in the Figure 7.

By means of carrying out Channel and Address adjustments on the gateway node designed, the gateway node can even be used together with different sensor nodes.

TESTING AND RESULTS

In order to evaluate the performance of the gateway node, two tests were run:

1. CPU usage.
2. Power consumption.

Results are given below.

1. The CPU usage was very small in all conditions. Approximately, it was 1%.
2. Power supply ratings of the gateway node depend on factors like configuration and load on the node. The gateway with a 12V power supply and measured current consumption in 6 scenarios were powered:

1. Gateway Node is POWER DOWN mode
2. Gateway Node is SLEEP mode
3. Gateway Node is IDLE mode
4. Gateway Node is TALK mode
5. Gateway Node is DATA mode, GPRS (3 Rx, 2Tx)
6. Gateway Node is DATA mode, GPRS (4 Rx, 1 Tx)

Average supply currents are given in Figure 8. Figure 8 indicates that the average supply current is as follows:

Scenario 1 – 0.03 mA, Scenario 2 – 1.5 mA, Scenario 3 – 200 mA, Scenario 4 – 235 mA, Scenario 5 – 435 mA, Scenario 6 – 266 mA. Therefore, this gateway node can be used in wireless sensor network applications.

CONCLUSIONS

The study is on a development made on a gateway node

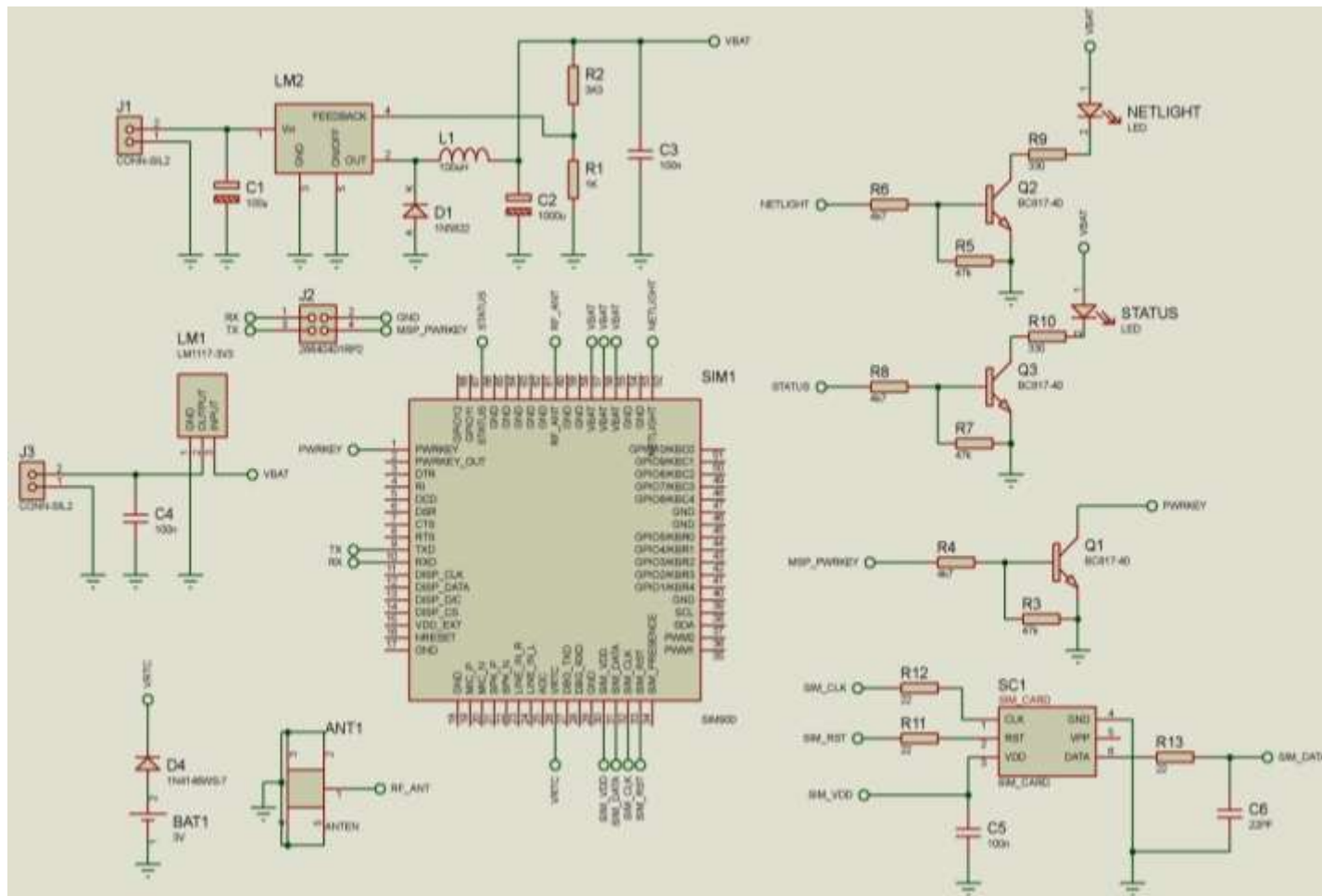

Figure 4. The circuit diagram of the SIM900 GSM/GPRS node.

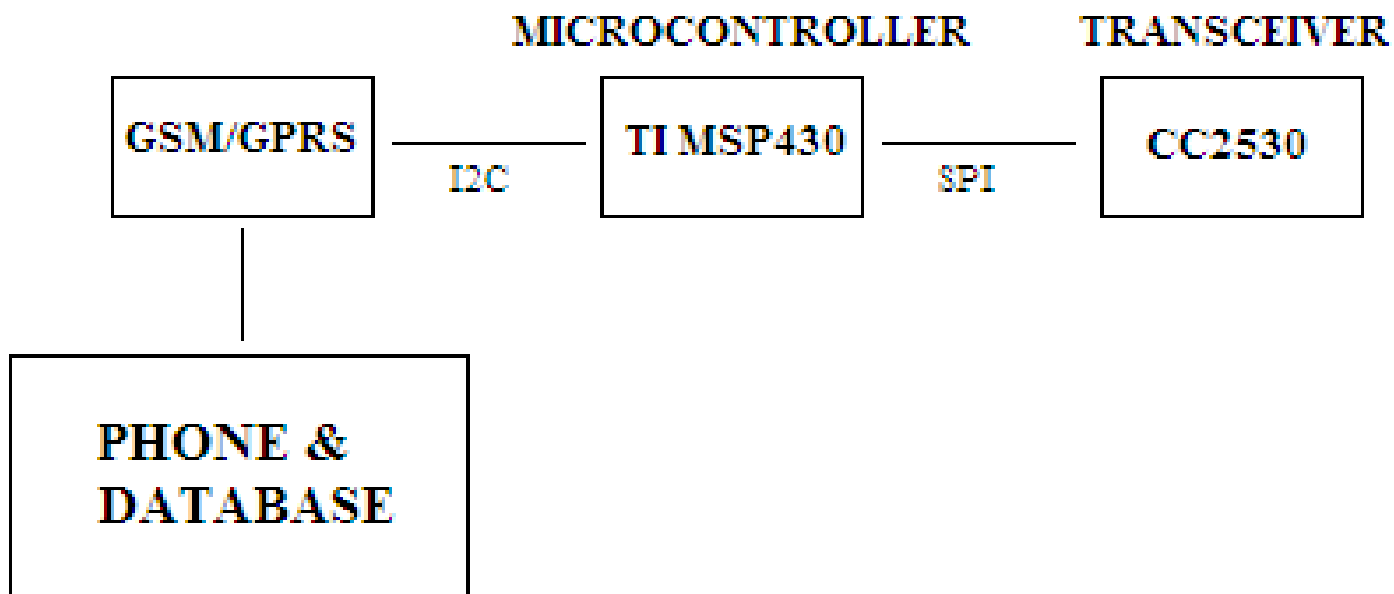

Figure 5. Structure of the Gateway Node developed.

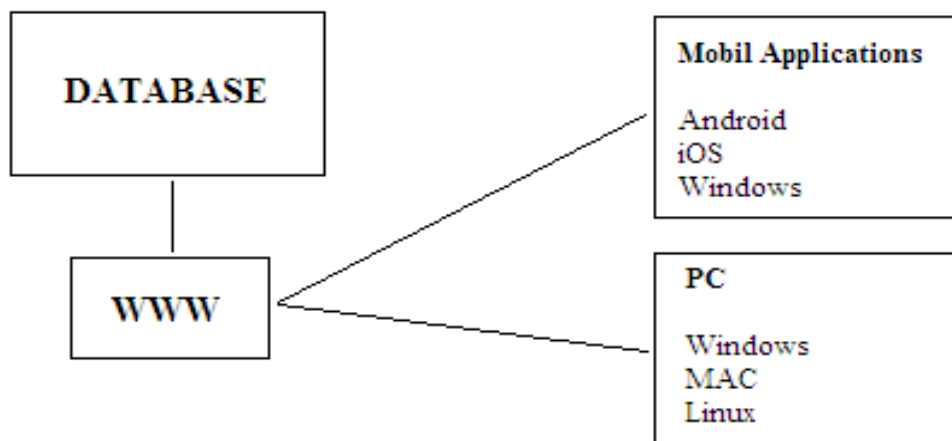

Figure 6. Database transactions.

Table 1. Data limitation of the general protocol run on ZigBee networks.

Octets: 2	1	0/2	0/2/8	0/2	0/2/8	Variable	2
Frame control	Sequence number	Destination PAN ID Addressing fields	Destination Address	Source PAN ID	Source Address	Frame Payload	FCS
MHR						MAC Payload	MFR

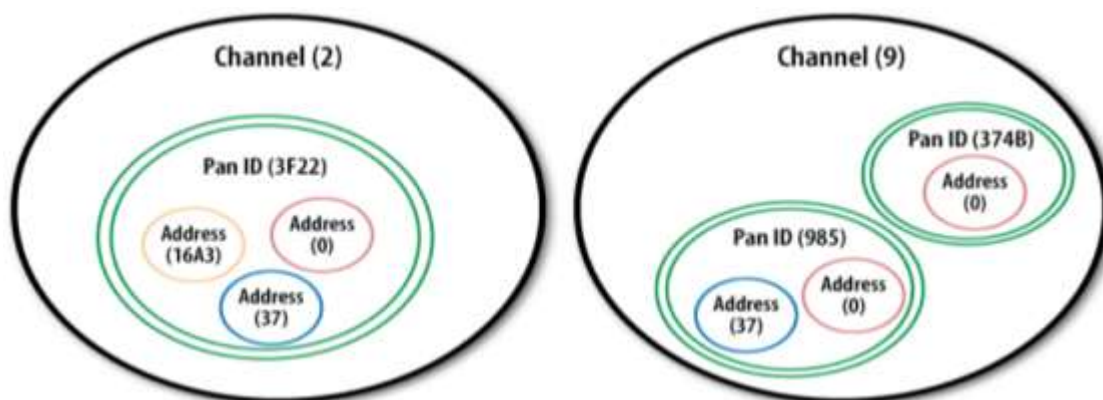

Figure 7. Channel, PAN ID, Address.

needed for the realisation of many wireless sensor network applications. By means of the new age gateway node prepared and designed for the purpose of developing a new and a user-friendly alternative, the detected data can be sent over the distant stations and can be monitored transiently. On the existing sensor nodes:

1. The software support is as much as given by the companies.
2. There is no alternative for gateway node. The node is connected to a PC and used as a gateway node in the

laboratories or classrooms.

On the gateway node developed however:

1. Data can be received from any wireless module.
2. The gateway node can directly communicate with the mobile phones as well as with the database.
3. The data can be traced over the web or mobile platforms in real time.
4. Software support can be provided fast and easily.

Since the gateway node is programmable, any desired

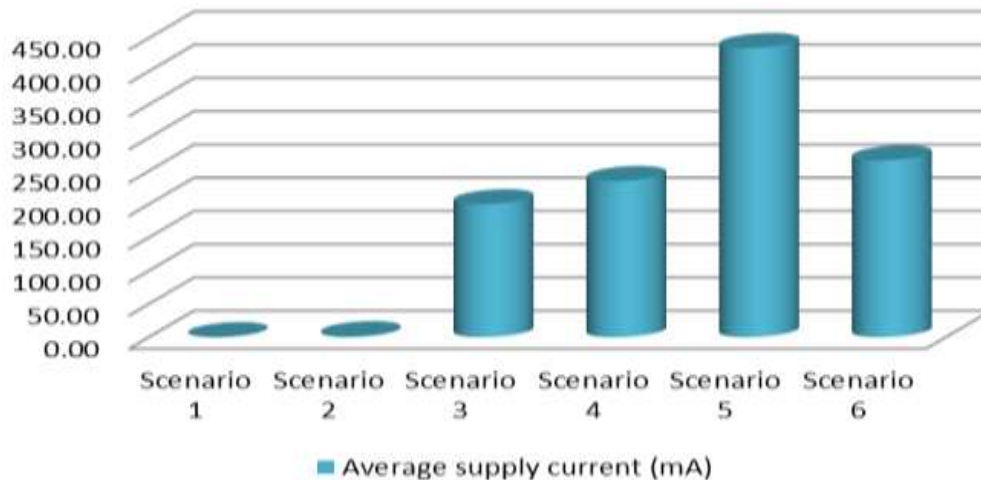

Figure 8. Average supply currents.

network structure can be established. This way, unnecessary power losses and program complications can be eliminated and new algorithms and techniques can be developed in terms of speed. Also, as a result of the gateway nodes being programmable:

1. An environment in which researches can be made in Wireless Sensor Networks was established
2. It was ensured that the theoretical knowledge applied in the Wireless Sensor Networks was reduced to a level that can be used in the daily life.

Thus, with the gateway node which is the subject for this study, a gateway node can be used in the areas requiring wireless sensor networks to be used such as smart home systems, building security systems, vehicle tracking systems, monitoring of power transmission lines, control of illumination systems, fire tracking systems, monitoring of patients, monitoring of medical parameters, earlier prediction of natural disasters, monitoring of agricultural activities, guarding of battle grounds and locating mobile targets. However, there is no such comprehensive and trouble-free solution in the known condition of the technique.

With the production of gateway node, rational, cheap, easy-to-use sensor nodes have been put into practise for people conducting researches in Wireless Sensor Networks and for Wireless Sensor Network applications in the field of application.

Conflict of Interests

The author has not declared any conflict of interests.

REFERENCES

Akyildiz IF, Su W, Sankarasubramaniam Y, Cayirci E (2002). A survey on sensor networks. *IEEE Commun. Mag.* 40(8):102-114.

- Carlos FG-H, Pablo HI-G, Joaquín GH (2007). Wireless Sensor Networks and Applications: A Survey. *IJCSNS Int. J. Comput. Sci. Netw. Secur.* 7(3):208-218.
- Chong C-Y, Kumar SP (2003). Sensor Networks: Evolution, opportunities, and challenges. *Proc. IEEE* 91(8):1247-1256.
- Gupta DK (2013). A Review on Wireless Sensor Networks. *Netw. Complex Syst.* 3(1).
- He HJ, Yue ZQ, Wang XJ (2009). Design and Realization of Wireless Sensor Network Gateway Based on ZigBee and GPRS. *Second International Conference on Information and Computing Science.*
- Manukonda R, Nakkala S (2015). The design and implementation of ZigBee-Wi-Fi Wireless Gateway. *Int. J. Comput. Sci. Netw. Secur.* 15:1.
- Mayank S (2005). A Survey of wireless sensor network, *EURASIP Journal on Wireless Communications and Networking.* pp. 774-788.
- Song P, Chen C, Li K, Sui L (2008). The Design and Realization of Embedded Gateway Based on WSN. *International Conference on Computer Science and Software Engineering.*
- Steenkamp LduT, Kaplan S, Wilkinson RH (2009). Wireless Sensor Network Gateway. *IEEE AFRICON, Nairobi, Kenya.*
- Sunitha N, Aruna Y, Devi S, Delip A (2013). The Design and Implementation of Wireless Gateway Using ZigBee Wi-Fi. *Int. J. Sci. Eng. Technol. Res.* 2:9.
- Wang W, Zou Y-X, Shi G, Zhu Y (2009). A Web Service based Gateway Architecture for Wireless Sensor Networks. 02:1160-1163.
- Wang Y, Si L, Liang S (2014). The Design of Wireless Sensor Network Gateway based on ZigBee and GPRS. *Int. J. Future Generat. Commun. Netw.* 7(2):47-56.
- Yepeng N, Fang M, Jianbo L, Jianping C (2013). Implementation of Wireless Gateway for Smart Home. *Commun. Netw.* 5:16-20.
- Zennaro M, Ntareme H, Bagula A (2008). On the design of a flexible gateway for Wireless Sensor Networks.
- Zhixiang Y, Jinxiang C (2013). The Design and Realization of Wireless Sensor Network Gateway Node. *Proceedings of the 2nd International Conference on Computer Science and Electronics Engineering.*
- ZigBee Alliance (2005). Zigbee specification. Technical Report Document 053474r06, Version 1.0, ZigBee Alliance.