

Full Length Research Paper

# Numerical investigation of flow characteristics and irradiance history in a novel photobioreactor

L. B. Wu, Z. Li\* and Y. Z. Song

School of Aerospace, Tsinghua University, Heat Transfer and Energy Conversion –The Key Laboratory of Beijing Municipality, Beijing, 100084, China.

Accepted 20 July, 2009

Mixing performance of photobioreactors where the microalgae grow up greatly affect the accessibility of nutrient substance as well as the availability of light for the cells, so it is of vital importance to properly design the geometry of photobioreactor. In this work, a kind of spiral photobioreactor was introduced. The flow characteristics of the fluid were obtained through computational fluids dynamics modeling. Cell trajectories of microalgae were determined by Lagrangian formulation and the light intensity histories of tracked cells were investigated by integrating Lagrangian approach with the irradiative model. The swirl numbers representing the mixing performances of the both photobioreactors were numerically calculated. Results show that strong swirl motions are formed in the cross-sections along axial coordinate of the spiral photobioreactor under laminar state, but no such vortice is observed for tubular photobioreactor. The light intensity histories of the tracked cells imply that the microalgae cells experience the so called light/dark cycle which is necessary to their growth. With high swirl number ranging from 0.1 to 0.45, the mixing performance of the spiral photobioreactor is much better than that of tubular PBR, indicating such innovative geometry is of great potential for mass culture of microalgae in the future.

**Key words:** Microalgae, mixing performance, spiral tube photobioreactor, flow characteristics, cell trajectories, light intensity history.

## INTRODUCTION

Microalgae accumulate biomass energy through the process of photosynthesis by absorbing light from outside world. The growth rate of microalgae is greatly affected by the systems designed for the culture of microalgae.

\*Corresponding author. E-mail: lizh@tsinghua.edu.cn. Tel.: +86-10-6278-1610. Fax: +86-10-6278-1610.

**Notation:**  $D$  - pipe diameter (m),  $I_D$  - direct solar irradiance,  $I_d$  - diffuse solar irradiance,  $L$  - length of the torus reactor (m),  $r$  - radial coordinate (m),  $R$  - pipe radius (m),  $Re$  - Reynolds number =  $\rho U_0 D / \mu$ ,  $S$  - the considered cross-sectional surface area,  $Sn$  - swirl number,  $U$  - mean axial velocity component ( $\text{ms}^{-1}$ ),  $U_0$  - mean bulk velocity ( $\text{ms}^{-1}$ ),  $V$  - mean circumferential velocity component ( $\text{ms}^{-1}$ ),  $z$  - axial coordinate (m),  $\mu$  - dynamic viscosity (Pa),  $\rho$  - fluid density ( $\text{kgm}^{-3}$ ).

Open systems (open pond) and closed systems named as photobioreactors (PBRs) are two alternative ways to attempt massive cultivation of microalgae. Due to the feasibility of controlled cultivation conditions, gaining high concentration of biomass and avoiding contamination from outside world, closed systems have proved to be more potential for large scale culture of microalgae. Therefore, many kinds of closed systems, such as stirred-tank reactors (Brucato et al. 1998; Ghadge et al., 2005; Lapin et al., 2006; Ogbonna et al., 1999), plate reactors (Hu et al., 1996), torus reactors (Pruvost et al., 2004, 2006), and tubular reactors (Borowitzka, 1999; Chini Zittelli et al., 1999; Del Campo et al., 2001; Pirt et al., 1983; Lee and Low, 1991; Harker et al., 1996; Watanabe and Saiki, 1997; Ugwu et al., 2002; Hall et al., 2003; Kaewpintong et al., 2007) have been discussed and investigated.

Compared with other kinds of PBRs, tubular PBR has the advantages of large illumination surface area and normally high biomass productivities (Ugwu et al., 2008),



**Figure 1.** A mass culture base of *Chlorella* in China.

and has been considered as one of the most promising PBRs for massive cultivation of microalgae. But in fact, few successful industrial applications of such kind of PBR for mass culture of microalgae have been reported. The problem is involved by the phenomena of photoinhibition caused by high light intensity illumination and photolimitation caused by cell's self-shading effects when the tubular PBRs are scaled up. A typical example of massive culture of microalgae is shown in Figure 1, which is a mass culture base for *Chlorella* in Gansu Province, China. The outer diameter and length of the each pipe are 0.085 m and 54 m, respectively. Theoretically, after 4 days of cultivation, the density of *Chlorella* can reach 2 g/kg. With an expected production of about 2200 kg/year (The total *Chlorella* liquid is about 24 tons. After about 4 days, half of *Chlorella* liquid is extracted, so the expected production per year is:  $12000 \text{ kg} \times 91 \times 2 \text{ g/kg} = 2184 \text{ kg}$ ), the practical production is quite unexpected of about only 300 kg/year. With an inner diameter of 0.075 m, the tubular PBR contains a large dark zone in the center of the pipes under mass and dense culture of *Chlorella*, indicating the microalgae cells at the inner part of the tube would not reach their growth condition for light. Therefore, the PBR performance characterized by mixing should be improved to enhance the intensity and the availability of light transferred to the microalgae cells (Merchuk et al.,

1998).

Static mixers were proposed and developed to generate effective mixing of microalgae fluid within tubular PBR and improve mass transfer performance inside tubular PBRs (Ugwu et al., 2002; Merchuk et al., 1998; Wu and Merchuk, 2001). Impellers of complex geometries and PBR bends were designed and investigated to invoke swirling motion of the microalgae fluid. With higher mixing efficiency than classical stirred tanks (Belleville et al., 1992; Nouri et al., 1997; Legrand et al., 1997), the torus PBRs combined with impellers were investigated for the flow patterns within the torus PBRs (Khalid et al. (1996), Khalid and Legrand (2001) and Pruvost et al. (2004, 2006).

In this paper, a kind of spiral tube PBR was introduced. The flow characteristics of the microalgae fluid within the spiral tube PBR was calculated by computational fluids dynamics (CFD) modeling software of FLUENT 6.2. Dean vortices were formed in the cross-sections of the spiral tube PBR under laminar state at  $Re = 500$ . Lagrangian formulation was used to determine the movements of microalgae cells. By integrating Lagrangian approach with the Discrete Ordinates (DO) radiation model, light histories of microalgae cells were numerical simulated. Ranging from 0.15-0.45, the swirl numbers calculated along the axial direction of the designed spiral tube PBR

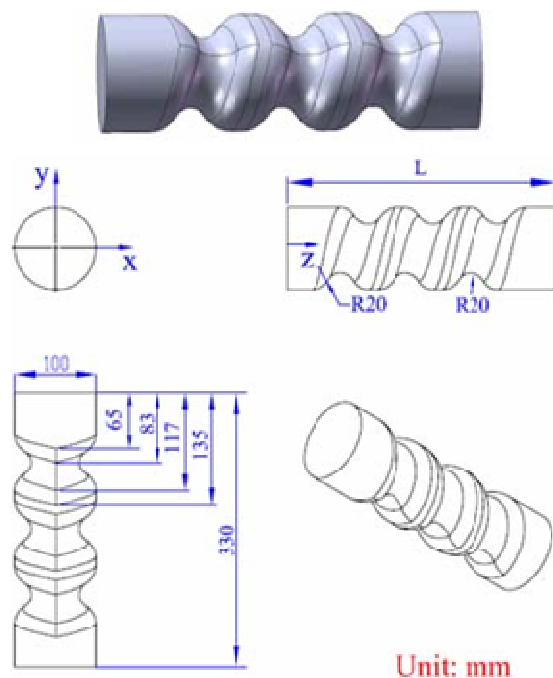

R20 represents that the profile radius is 20 mm.

**Figure 2a.** Schematic diagrams of the PBRs: for spiral PBR.

are much higher than that of tubular PBR (values of which are close to zero). Furthermore, the spiral geometry of PBR has larger illumination surface than tubular PBR. Combining these advantages of the spiral PBR together, it is conceivable that this high degree of mixing generated by the spiral tube PBR and low work consumption are of great potential for large scale commercial cultivation of microalgae in the future.

## DESCRIPTION OF THE SPIRAL TUBE PBRs

Schematic diagram of the spiral PBR is shown in Figure 2. The diagrams of Figure 2a and b are for spiral PBR and tubular PBR, respectively. Relative sizes of the PBRs are labeled in Figure 2. The assembly diagrams in Figure 2 were drawn by software Solidworks 2007. The engineering graphics were drawn by software AutoCAD 2004. With a mean bulk fluid velocity  $U_0 = 0.05$  m/s corresponding to a Reynolds number  $Re = 500$ , the microalgae fluid at the entrance of the PBRs is under laminar state.

## NUMERICAL METHOD AND DETAILS

### Mesh generation

Three-dimensional meshes of the PBRs were created by software ANSYS ICEM CFD with elementary tetra volumes. Periodicity of translational periodic type was

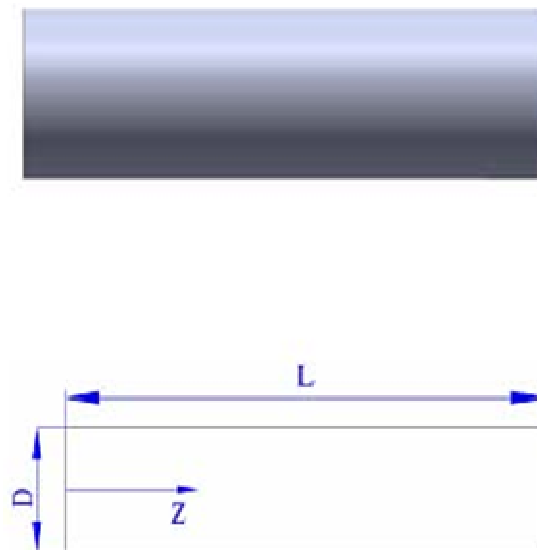

**Figure 2b.** Schematic diagrams of the PBRs: for tubular PBR.

defined for determining the boundary conditions of the PBRs. Tessellated meshes were employed for wall zones to decrease the effects of boundary.

## Simulation model and numerical details

Flow characteristics of microalgae fluid, light intensity histories of tracked cells and swirl numbers within the spiral PBRs were numerically simulated by Commercial software FLUENT 6.2. With a mean bulk fluid velocity  $U_0 = 0.05$  m/s, the Reynolds number  $Re$  equals to 500, therefore, the viscous model of laminar was chosen to determine the velocity profiles of microalgae fluid. Normally, the PBRs designed for massive cultivation of microalgae are very long (the length of each pipe is 54 m in the mass culture base for *Chlorella* in Gansu Province, China), so inlet flow of the PBRs can be regarded as fully developed state and Periodic Boundary Conditions can be employed for determining steady state flow dynamics of microalgae fluid.

The procedure of "SIMPLEC" was selected for pressure-velocity coupling with a "QUICK" interpolation scheme for momentum. The under-relaxation factors in FLUENT 6.2 were retained unchanged. Computation processes proceeded until all residual criteria convergence was achieved.

## NUMERICAL RESULTS AND DISCUSSION

### Velocity distributions of microalgae fluid

Numerical simulations of velocity field distributions are investigated by CFD modeling. With an inlet velocity of  $U_0 = 0.05$  m/s, the resulting velocity profiles of different

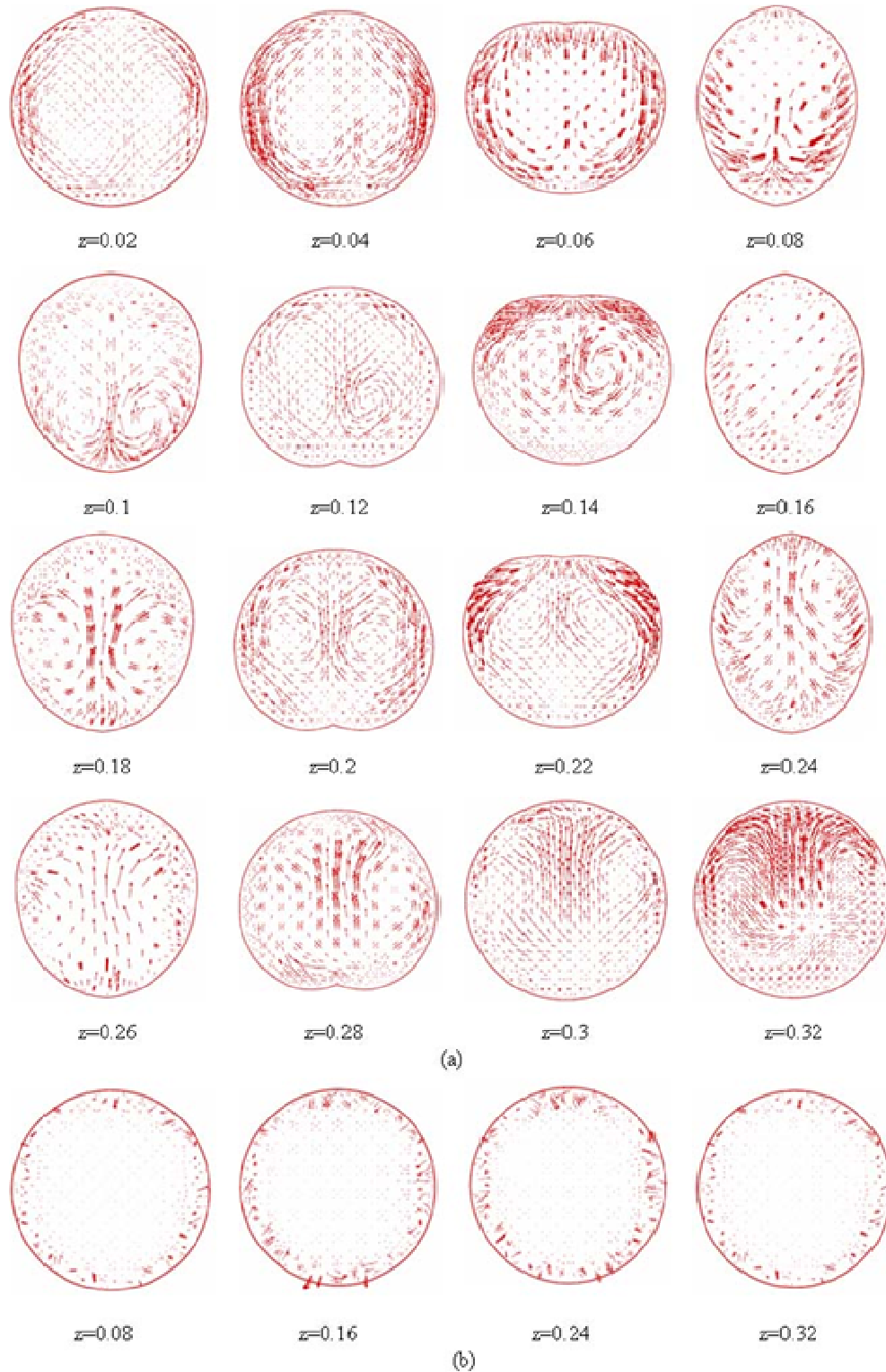

**Figure 3.** Evolution of the flow structure in different cross-sections of the PBRs: (a) for spiral PBR; (b) for tubular PBR.

cross-sections along axial coordinate of the spiral and the tubular PBRs are given in Figure 3. The cross-sectional planes along the axial coordinate range from 0.02 m to

0.32 m with an interval of 0.02 m. As shown in Figure 3a, strong Dean vortices were formed in cross-sections of the spiral tube PBRs under laminar flow state, indicating a

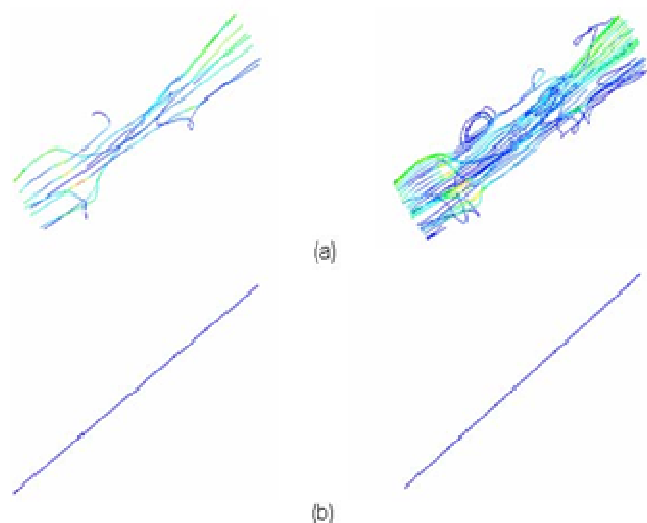

**Figure 4.** Example of cell trajectories determined by Lagrangian approach: (a) for spiral PBR; (b) for tubular PBR. Left: Number of simulated cells =5; right: Number of simulated cells =15.

high mixing condition is achieved. However, no vortice is formed in the cross-sections of the tubular PBR (Figure 3b).

It is well known that the growth rate of the microalgae cells is greatly affected by the Dean vortices motion of the microalgae fluid within the PBRs, which will realize the so-called light/dark cycle for microalgae cells circulating from the illuminated surface to the dark center. The Dean vortices motion generated by those stirred tank bioreactors (Brucato et al. 1998; Ghadge et al., 2005), the static mixers inside tubular PBRs or the impellers within torus PBRs implies that the microalgae fluids are in turbulent flow state. Then high work consumption is necessary to maintain the turbulent flow state of microalgae fluid inside the PBRs. However, Dean vortices motion generated by the spiral PBR is under laminar flow state of  $Re = 500$ . Furthermore, the strong swirling motion involved by the spiral PBR can maintain stable along the axial coordinate as shown in Figure 3a, which is different from the swirl decaying motion proposed by Pruvost et al. (2004, 2006). Therefore, this kind of proposed spiral PBR generating strong swirling motion under laminar flow state is of great potential for massive cultivation of microalgae. Results will be given in Section 4.4 as to the exactly swirl intensities between the spiral PBR and tubular PBR under laminar state.

#### Particle tracking of cell trajectories inside the PBRs

Lagrangian formulation was adapted to investigate the cell trajectories by injecting particles. A full description and its validation verification are given by Pruvost et al. (2008). For determining the trajectories of microalgae, the

velocity distributions of the microalgae fluid are previously identified through numerical calculation or experimental investigation (Perner-Nochta and Posten, 2007; Pruvost et al., 2008). The determination of cell trajectories were obtained by CFD modeling for the discussed PBRs in this paper as it has been proved to be an effective way to investigate flow dynamics inside torus PBRs (Pruvost et al., 2006, 2008).

The Discrete Random Walk Model (DRW) was employed to numerically ascertain the lifetime of the cell trajectories. Assume that the density of microalgae cells are the same as the fluid, mass effect of the microalgae cells on the flow field can be neglected. The correction of pathlines can be ignored as the diameters of microalgae cells are less than or close to  $10 \mu m$ , smaller than the Kolmogorov scale. Therefore, microalgae cells can be treated as passive tracers in cell trajectories calculation.

An example of particle tracing of cell trajectories is given in Figure 4 at an inlet velocity of  $U_0 = 0.05$  m/s. The diagrams of Figure 4a and b are the cell trajectories of the spiral and tubular PBRs, respectively. The injected cells' numbers are 5 and 15 for the left and right diagrams, respectively. Swirling and rotating motions are obtained for spiral PBR along the radial and axial coordinates which means the microalgae cells inside the spiral PBR could easily experience the light/dark cycle, while, the cell trajectories are almost identical for tubular PBR (In fact, the cell trajectories are not straight lines; they are vibrate a little along the axial direction (as shown in Figure 6b, while, the vibrations (smaller than  $10^{-3}$  m) are so small that they can not be reflected as compared to the diameter (equals to  $10^{-1}$  m) of the tubular reactor. So the cell trajectories for tubular reactor seems to be straight lines), indicating the microalgae cells have no obvious fluctuation of received light intensity and exchange of nutrient substance. The fluctuation of microalgae cells' radial positions and received irradiance are given in following photograph.

#### Radial position and irradiance history of the PBRs

By integrating the Discrete Ordinates (DO) radiation model, Lagrangian formulation was used to identify the radial positions and irradiance histories of tracked microalgae cells within the PBRs. Direct coupling of light transfer and flow dynamics has been studied by Pruvost et al. (2006,2008). By projecting trajectory along the axial direction of each PBR, received light irradiance and history for microalgae cell within the PBRs can be easily determined. The solar load in DO radiation model is composed by direct solar irradiance  $I_D$  and diffuse solar irradiance  $I_d$ . A schematic diagram of solar radiation is given in Figure 5 and the values of illumination parameters are given in Table 1.

An example of cells' displacement along the light gra-

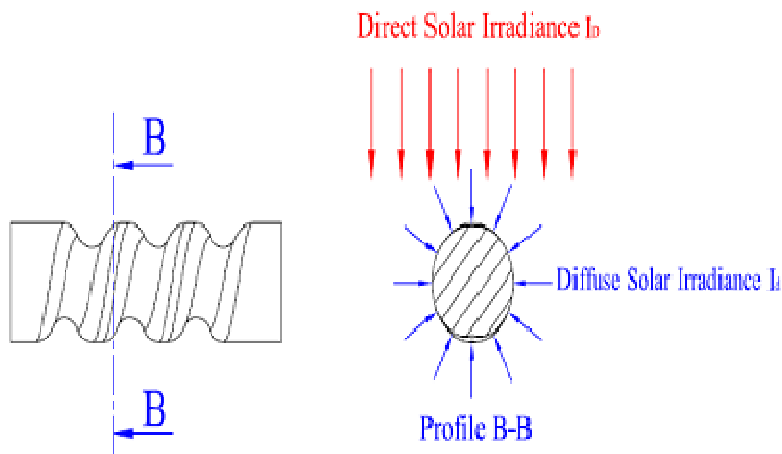

**Figure 5.** Schematic diagram of solar radiation for an arbitrary cross section of discussed PBRs.

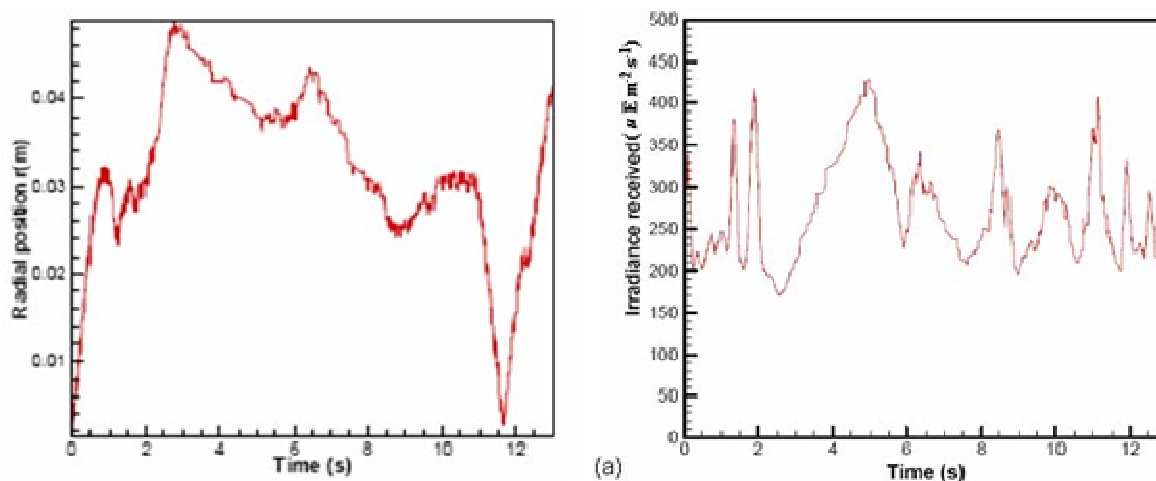

**Figure 6a.** Example of cell displacement along the light gradient (left) and of corresponding received irradiance (right) in the PBRs. For spiral PBR.

dient and of corresponding received irradiance is shown in Figure 6. As can be seen from Figure 6a, the microalgae cell are submitted to a complex fluctuating position regime and light irradiance zone caused by flow dynamics. The tracked cell experiences fast irradiance fluctuations of illumination as the cell flow through the lighted regime or dark periods, implying that the microalgae cell in the spiral PBR accomplishes the so called light/dark cycle necessary to their growth. But for tubular PBR, the position and light intensity of the tracked cell do not fluctuate apparently along the axial coordinate. From the point of availability and intensity of light for microalgae cells, spiral PBR is superior to tubular PBR.

### Swirl intensity of the PBRs

The swirl number  $Sn$  has been proved to be a qualified

criterion to determine the mixing characteristics of the torus PBRs (Pruvost et al. 2002). In this paper, the swirl number  $Sn$  was also employed to investigate the mixing performance for the spiral PBR. Following the definition of Gupta et al. (1984), the expression of the swirl number  $Sn$  for a cross-section can be written as,

$$Sn = \frac{\iint_S UVr \, dS}{\iint_S U^2 r \, dS} \quad (1)$$

Where  $U$  is the mean axial velocity component;  $V$  is the mean circumferential velocity component;  $r$  represents the radial distance and  $S$  is the considered cross-sectional surface area as shown in Figure 7a.

The swirl number evolution along the axial direction of

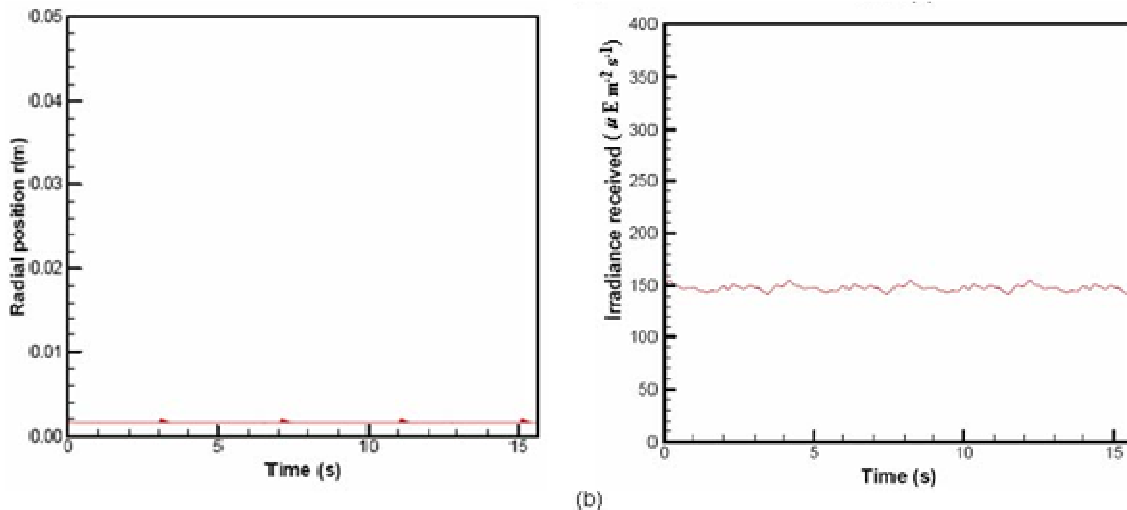

**Figure 6b.** Example of cell displacement along the light gradient (left) and of corresponding received irradiance (right) in the PBRs. For tubular PBR.

**Table 1.** Illumination parameters for the PBRs.

Direct solar irradiance $I_D$ ( $\mu E m^{-2} s^{-1}$ )	Diffuse solar irradiance $I_d$ ( $\mu E m^{-2} s^{-1}$ )	Absorption coefficient (1/m)	Scattering coefficient (1/m)
400	40	0.6	0

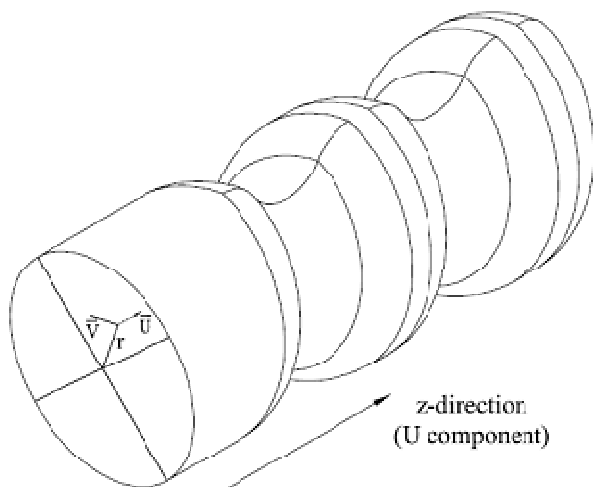

**Figure 7a.** Coordinate system for  $Sn$  calculation.

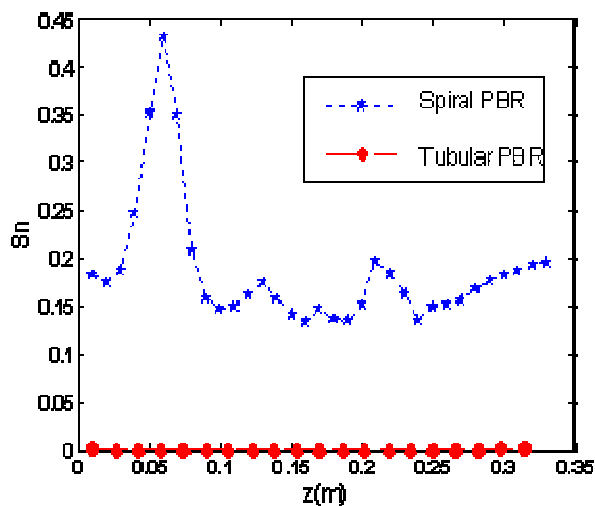

**Figure 7b.**  $Sn$  Evolution along z coordinates.

spiral tube and tubular PBRs are shown in Figure 7b. It is noticeable that the swirl numbers  $Sn$  of spiral tube PBR ranging from 0.1 - 0.45 are much higher than that of tubular PBR which are close to zero, meaning that the mixing performances of the cross sections for spiral PBR are much better than that of tubular PBR. With high swirl

numbers for spiral PBR proposed in this paper, the mixing performance of microalgae fluid under laminar state with  $Re = 500$  even better than the results of torus PBRs, ranging from 0 to 0.3 under turbulent state, obtained by Pruvost et al. (2004, 2006). This reflects that the novel geometry of spiral PBR needs much lower work consum-

ption (the pressure drop is only 30.45 Pa/m. Although the pressure drop for tubular PBR at  $Re = 500$  is only 1.94 Pa/m, much lower than spiral PBR at  $Re = 500$ . While, normally, the fluids within large scale tubular PBR are at turbulent state, which means the practical pressure drop for tubular PBR is very high. For instance, the pressure drop is 225 Pa/m for this tubular PBR under  $Re = 3450$  to reach high mixing performance). Meanwhile, the evolution values of swirl number  $Sn$  along z coordinate mostly fluctuate from 0.1 - 0.2, which means that swirling motions generated by the spiral PBR can maintain stable constructions along the axial coordinate and this phenomenon is verified by the velocity profiles in Section 4.1.

## Conclusion

A novel spiral PBR is introduced in this paper. Flow dynamics of microalgae fluid, radial positions and irradiance histories of tracked cells as well as velocity profiles and swirl numbers of cross sections inside the spiral PBR were numerically simulated. Hydrodynamic conditions of the PBRs imply that the cell trajectories of the spiral PBR rotate and twist more drastically than that of tubular PBR under laminar state of  $Re = 500$ . The swirl numbers representing the mixing performance of the spiral PBR ranging from 0.1 - 0.45 are much higher than the tubular PBR's, which are close to zero. Irradiance history of tracked cell for spiral PBR means that the light/dark cycle necessary to the growth of microalgae can be easily realized.

With high mixing performance and low work consumption, this kind of spiral tube PBR provides a new thought for designing PBRs and possible applications for massive and industrial cultivation of microalgae in the not far future.

## ACKNOWLEDGEMENTS

We greatly appreciate for the "985 Project" Foundation funded by Tsinghua University and the Chlorella culture base picture provided by Qian Xuesen Sand Industry Center Laboratory in Gansu Province, China.

## REFERENCES

- Belleville P, Nouri L, Legrand J (1992). Mixing characteristics in the torus reactor. *Chem. Eng. Technol.* 15 (4): 282-289.
- Borowitzka MA (1999). Commercial production of microalgae: ponds, tanks, tubes and fermenters. *J. Biotechnol.* 70(1-3): 313-321.
- Brucato A, Ciofalo M, Grisafi F, Micale G (1998). Numerical prediction of flow-fields in baffled stirred vessels: a comparison of alternative modelling approaches. *Chem. Eng. Sci.* 53(21): 3653-3684.
- Chini Zittelli G, Lavista F, Bastianini A, Rodolfi L, Vincenzini M, Tredici MR (1999). Production of eicosapentaenoic acid by *Nannochloropsis* sp. cultures in outdoor tubular photobioreactors. *J. Biotechnol.* 70 (1-3): 299-312.
- Del Campo JA, Rodríguez H, Moreno J, Vargas MA, Rivas J, Guerrero MG (2001). Lutein production by *Muriellopsis* sp. in an outdoor tubular photobioreactor. *J. Biotechnol.* 85(3): 289-295.
- Ghadge RS, Patwardhan AW, Sawant SB, Joshi JB (2005). Effect of flow pattern on cellulase deactivation in stirred tank bioreactors. *Chem. Eng. Sci.* 60(4): 1067-1083.
- Gupta AK, Lilley DG, Syred N (1984). *Swirl Flows*, Abacus Press, Cambridge.
- Hall DO, Fernandez FGA, Guerrero EC, Rao KK, Grima EM (2003). Outdoor helical tubular photobioreactors for microalgal production: modeling of fluid-dynamics and mass transfer and assessment of biomass productivity. *Biotechnol. Bioeng.* 82(1): 62-73.
- Harker M, Tsavalos AJ, Young AJ (1996). Autotrophic growth and carotenoid production of *Haematococcus pluvialis* in a 30 liter airlift photobioreactor. *J. Fermentation Bioengin.* 82(2): 113-118.
- Hu Q, Guterman H, Richmond A (1996). A flat inclined modular photobioreactor for outdoor mass cultivation of phototrophs. *Biotechnol. Bioeng.* 51(1): 51-60.
- Kaewpintong K, Shotipruk A, Powtongsook S, Pavasant P (2007). Photoautotrophic high-density cultivation of vegetative cells of *Haematococcus pluvialis* in airlift bioreactor. *Bioresour. Technol.* 98 (2): 288-295.
- Khalid A, Legrand J (2001). Energy dissipation distribution and mixing in a torus reactor. *Chem. Eng. Communications*, 185(1): 141-164.
- Khalid A, Legrand J, Rosant JM (1996). Turbulent flow induced by an impeller in a closed toroidal loop. *J. Fluids Eng.* 118(4): 677-684.
- Lapin A, Schmid J, Reuss M (2006). Modeling the dynamics of *E. coli* populations in the three-dimensional turbulent field of a stirred-tank bioreactor—A structured-segregated approach. *Chem. Eng. Sci.* 61 (14): 4783-4797.
- Lee YK, Low CS (1991). Effect of photobioreactor inclination on the biomass productivity of an outdoor algal culture. *Biotechnol. Bioeng.* 38(9): 995-1000.
- Legrand J, Guéguen J, Berot S, Popineau Y, Nouri L (1997). Acetylation of pea isolate in a torus microreactor. *Biotechnol. Bioeng.* 53(4): 410-414.
- Merchuk JC, Ronen M, Giris S, Arad S (1998). Light/dark cycles in the growth of the red microalga *Porphyridium* sp. *Biotechnol. Bioeng.* 59(6): 705-713.
- Nouri L, Legrand J, Popineau Y, Belleville P (1997). Enzymatic hydrolysis of wheat proteins. Part II. Comparison of performance of batch-stirred and torus reactors. *Chem. Eng. J.* 65(3): 195-199.
- Ogbonna JC, Soejima T, Tanaka H (1999). An integrated solar and artificial light system for internal illumination of photobioreactors. *J. Biotechnol.* 70(1-3): 289-297.
- Perner-Nochta I, Posten C (2007). Simulations of light intensity variation in photobioreactors. *J. Biotechnol.* 131(3): 276-285.
- Pirt SJ, Lee YK, Walach MR, Pirt MW, Balyuzi HHM, Bazin MJ (1983). A tubular photobioreactor for photosynthetic production of biomass from carbon dioxide: design and performance. *J. Chem. Technol. Biotechnol.* 33B: 35-38.
- Pruvost J, Legrand J, Legentilhomme P, Muller-Feuga A (2002). Trajectory Lagrangian model for turbulent swirling flow in an annular cell Comparison with RTD measurements. *Chem. Eng. Sci.* 57(7): 1205-1215.
- Pruvost J, Legrand J, Legentilhomme P, Rosant JM (2004). Numerical investigation of bend and torus flows-Part II: Flow simulation in torus reactor. *Chem. Eng. Sci.* 59(16): 3359-3370.
- Pruvost J, Pottier L, Legrand J (2006). Numerical investigation of hydrodynamic and mixing conditions in a torus photobioreactor. *Chem. Eng. Sci.* 61(14): 4476-4489.
- Pruvost J, Cornet JF, Legrand J (2008). Hydrodynamics influence on light conversion in photobioreactors: An energetically consistent analysis. *Chem. Eng. Sci.* 63(14): 3679-3694.
- Ugwu CU, Ogbonna JC, Tanaka H (2002). Improvement of mass transfer characteristics and productivities of inclined tubular photobioreactors by installation of internal static mixers. *Appl. Microbiol. Biotechnol.* 58(5): 600-607.
- Ugwu CU, Aoyagi H, Uchiyama H (2008). Photobioreactors for mass cultivation of algae. *Bioresour. Technol.* 99(10): 4021-4028.
- Watanabe Y, Saiki H (1997). Development of photobioreactor incorporating *Chlorella* sp. for removal of CO<sub>2</sub> in stack gas. *Energy Conversion Manag.* 38(19): 499-503.
- Wu X, Merchuk JC (2001). A model integrating fluid dynamics in photosynthesis and photoinhibition processes. *Chem. Eng. Sci.* 56(11): 3527-3538.