

Full Length Research Paper

Lectin receptor kinase LecRK-b2 localizes to plasma membrane and functions as a homodimer

Keqin Deng, Xiushan Li, Dashi Yu, Qiming Wang, Jianxin Zeng, Xiaoying Zhao, Dongying Tang and Xuanming Liu*

Bioenergy and Biomaterial Research Center, Bioscience and Biotechnology Institute, Hunan University, Changsha 410082, China.

Accepted 10 July, 2009

An *Arabidopsis* putative lectin receptor-like serine/threonine kinase gene, LecRK-b2, has been characterized. Confocal microscopy images showed that the LecRK-b2-GFP fusion protein is localized to plasma membrane. The results of yeast 2 hybrid showed that lectin domain of LecRK-b2 had self-interaction, while the kinase domain did not work. Split luciferase complementation assays confirmed the yeast two hybrid results and suggested that lectin domain was responsible for the dimerization of LecRK-b2 protein in plant. Furthermore, the recombinant LecRK-b2 protein exhibited autophosphorylation activity.

Key words: Lectin receptor kinases, subcellular localization, homodimer.

INTRODUCTION

Lectin receptor kinase (LecRK) is a class of putative plant receptor serine/threonine kinases with an extracellular legume lectin-like domain. The most obvious putative function of LecRK genes concerns the transduction of extracellular oligosaccharide signals (Barre et al., 2002). But it is not clear at present whether the lectin-like domain of LecRK can specifically bind carbohydrates. Recent studies suggested some other potential roles for these LecRK. LecRK could be involved in legume-rhizobia symbiosis and pathogens resistance. For instance, a B-lectin receptor kinase gene conferring rice blast resistance (Chen et al., 2006), 4 *Medicago* LecRK genes play potential role in the symbiosis with *Sinorhizobium meliloti* (Navarro et al., 2003). Gene transcription level of some LecRK also increases in the case of infection, natural ageing, wounding, and treatment by ABA (abscisic acid) or elicitors (Kim et al., 2000; Riou et al., 2002; Sasabe et al., 2007). It implies LecRK might play a role in biotic and

abiotic stress signal transduction. In addition, LecRK also functions in plant development. *Arabidopsis* LecRK gene SGC and *Brassica oleracea* gene SRK₆ has been found to take part in pollen development and self-incompatible (Wan et al., 2008).

Previous studies have proved that receptor-like kinase (RLK) usually exist as or function as homodimer or heterodimer. Some RLK can form oligomers in the absence of ligand (Giranton et al., 2000; Shimosato et al., 2007), while some homodimerization, especially heterodimerization, were ligand dependent (Wang et al., 1995; Baer et al., 2001; Schlessinger, 2002). Since many RLKs have been shown to be activated by dimerization (Spaargaren et al., 1991), receptor homodimerization is now viewed as insufficient for RLK activation (Jiang and Hunter 1999), rather, receptor homodimerization or oligomerization only serves to bring the intracellular domains of RLK in close proximity for transphosphorylation and recruitment of effector cytoplasmic proteins (Schlessinger, 2002).

There are about 42 LecRKs in *Arabidopsis*; only few of them have been studied. To date, there is no report about their structural module. Here we demonstrated that *Arabidopsis* lectin protein kinase LecRK-b2 is localized to plasma membrane. The results of yeast two hybrid and split luciferase complementation assays showed that

*Corresponding author. E-mail: sw_xml@hnu.cn. Fax: +86-0731-8821721.

Abbreviations: LecRK, Lectin receptor kinase; RLK, receptor like kinase; GFP, green fluorescent protein; LUC, luciferase; EDTA, ethylenediaminetetraacetic acid.

Table 1. Primers used in this study.

Primer name	Sequence 5'-3'	Enzyme site
b2GFPF	<i>GGGGACAAGTTTGTACAAAAAAGCAGGCTTCATGTCTCTGCTTCTAAAGATGTTATTA</i>	
b2GFPR	<i>GGGGACAAGTTTGTACAAAAAAGCAGGCTTCTTAGCGTCCACTAGAGAGAAACGAT</i>	
PBoutF	<i>CGCGGATCCATGTCTCTGCTTCTAAAGATGTTAT</i>	BamHI
PBoutR	<i>TGCACTGCAGAAGATCTTAGAACTCAACGACCGT</i>	PstI
PAoutF	<i>GAATTCATATGATGTCTCTGCTTCTAAAGATGTTA</i>	NdeI
PAoutR	<i>CGCGGATCCAAGATCTTAGAACTCAACGACCGT</i>	BamHI
PBinF	<i>CGCGGATCCAAGAGGAAGAAGTTCTTGAAGTTA</i>	BamHI
PBinR	<i>CGCGTGCAGCTTAGCGTCCACTAGAGAGAAACGAT</i>	Sall
PAinF	<i>GGGAATTCATATGAAGAGGAAGAAGTTCTTGAAGTTA</i>	NdeI
PAinR	<i>CGCGGATCCTTAGCGTCCACTAGAGAGAAACGAT</i>	BamHI
NLecrkNLuc-F	<i>AAAAGTACTATGTCTCTGCTTCTAAAGATGTTAT</i>	SacI
NLecrkNLuc-R	<i>ACGCGTCGACCTCAATAACTTCCAAGAACTTCTT</i>	Sall
NLecrkCLuc-R	<i>AAAAGTACTTCAATAACTTCCAAGAACTTCTT</i>	SacI
CLecrkNLuc-F1	<i>GGATCAAGAACGGTCGTTGAGTTC</i>	
CLecrkNLuc-R1	<i>TGCAGGCGTCCACTAGAGAGAAACGATT</i>	
CLecrkNLuc-F2	<i>TGCAGGATCAAGAACGGTCGTTGAGTTC</i>	PstI
CLecrkNLuc-R2	<i>GGCGTCCACTAGAGAGAAACGATT</i>	PstI
FLecrkNLuc-R	<i>ACGCGTCGACCGGTCCTACTAGAGAGAAACGATT</i>	Sall
FLecrkCLuc-R	<i>AAAAGTACTGCGTCCACTAGAGAGAAACGATT</i>	SacI
rLecrk-F	<i>CCGCTCGAGATGGACCCAACCGGTGGACAG</i>	XhoI
rLecrk-R	<i>CCCAAGCTTTTAGCGTCCACTAGAGAGAAACGAT</i>	HindIII

lectin domain was responsible for the dimerization of LecRK-b2 protein in plant. Furthermore, the recombinant LecRK-b2 protein exhibited autophosphorylation activity.

MATERIALS AND METHODS

35S:LecRK-b2:GFP construction and GFP observation

Constructs expressing LecRK-b:GFP fusion was prepared using the gateway system (Invitrogen). *LecRK-b2* cDNA was amplified with b2GFPF/ b2GFPR primers (Table 1). *Italic* sequences are BP transferase recognition sites. The PCR fragment was cloned into pDONR201 by BP reaction and confirmed by sequencing analysis, then subcloned into destination vector 35S-GW-GFP (Kan) for 35S:LecRK-b2:GFP construction through LR reaction. Gateway clone system was ordered from Invitrogen. 35S-GW-GFP (Kan) was a gift from F. Turck (Max-Planck Institute for Plant Breeding Research, Cologne, Germany). 35S:LecRK-b2:GFP was transformed into the *Arabidopsis thaliana* ecotype Columbia, using floral dip method (Clough and Bent 1998). Independently 35S:LecRK-b2:GFP transformed lines were used for GFP observation.

For observing GFP in transgenic plants, seeds of T2 transformants were surface sterilized and sown on the MS-Agar culture medium (0.5× MS salt and 0.8% Agar at pH 5.8) in a petri dish. After a cold treatment (4°C) for 3 days in the dark, the seeds were germinated and seedlings were grown in a growth chamber under a 16 h/8 h light/dark cycle at 23 ± 1°C. Light was supplied by cool-white fluorescent bulbs, reaching an intensity of approximately 80 μmol m⁻² s⁻¹. Roots of 5-day old seedlings were used for subcellular protein localization analysis using a laser scanning confocal microscope (ZEISS LSM 510 META). 8 independent transformant lines from each gene were used for GFP localization examination. To observe GFP in cell membranes, 0.4 M mannitol solution was applied to the roots on glass slides to induce plasmolysis.

Yeast 2-hybrid analysis

Experiments using the yeast two-hybrid system are as described (Liu et al., 2008), and according to the manufacturer's instructions (Matchmaker user's manual, Clontech, California). The lectin domain NLecRK-b2 (1-834 bp of LecRK-b2 cDNA) was PCR-amplified by using the primers PBoutF, PBoutR and PAoutF, PAoutR, and cloned into the bait vector pBridge and prey vector pGADT7 plasmids (Clontech), respectively. The kinase domain CLecRK-b2 (904-1971 bp of LecRK-b2 cDNA) were PCR-amplified by using the primers PBinF, PBinR and PAinF, PAinR and cloned into the pBridge and pGADT7 plasmids (Clontech), respectively. The bait plasmid and the prey plasmids were co-transformed into the yeast strain Y190. Incubate plates at 30°C until colonies appear (2 - 4 days).

To analyze LecRK-b2 domain interaction by the histidine auxotrophy assay, yeast cells harboring bait and prey plasmid were resuspended in sterile water and dropped onto SD medium-His/+3AT (50 mM) and +His plates and kept at 30°C for 2 days. For quantitative β-galactosidase assay, yeast cells were grown overnight in SD medium (-His), diluted 5 folds in YPD medium, grown for 3-5 h, to keep the cell density between 0.4 - 0.5 OD600.

For the β-galactosidase colony-lift assay, each transformant was grown on an agar plate at 30°C for 2 days. Then the yeast cells were scraped from the agar plate and painted on the Whatman paper filters. The filters with colonies were subjected to 3 cycles of freezing and thawing between liquid nitrogen and room temperature. The filters were then placed onto other filter papers presoaked with Z buffer (60 mM Na₂HPO₄, 40 mM NaH₂PO₄, 10 mM KCl, 1 mM MgSO₄, pH 7.0) containing 334 μg.ml⁻¹ 5-bromo-4-chloro-3-indolyl-D-galactopyranoside and incubated at 30°C for detecting galactosidase activity by observing the development of blue color. The plasmids for positive controls were pBridge-CRY2 and pGAD-T7-COP1.

For the β-galactosidase liquid culture assay, chlorophenol red-β-D-galactopyranoside (Calbiochem#220588) was used as substrate.

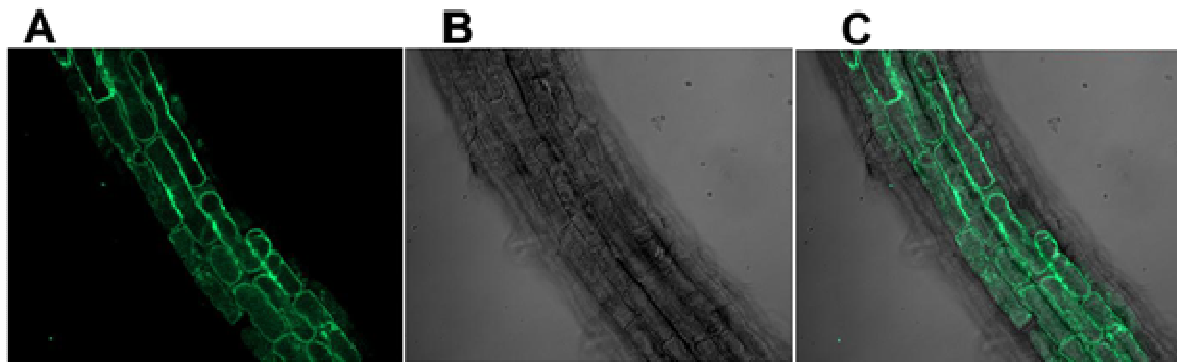

Figure 1. Confocal microscopy showing the protein subcellular localization of LecRK-b2::GFP in plasmolyzed root cells: A. fluorescence image, B. bright field image, and C. conformity of both (A) and (B).

Split luciferase complementation assay

Split luciferase (LUC) complementation assay was performed as described (Chen et al., 2008). NLecRK-b2 (1-933 bp of LecRK-b2 cDNA), CLecRK-b2 (802-1968 bp of LecRK-b2 cDNA) and full length LecRK-b2 (1-1968 bp of LecRK-b2 cDNA) was PCR-amplified with primers listed in Table 1 (italic sequences are restriction enzyme cutting sites) and inserted into 35S:NLUCor 35S:CLUC plasmids to construct the split LUC vectors. These split LUC vectors were used for transfection of protoplasts.

Protoplasts were isolated from 4-week-old Columbia-4 plants according to Sheen (<http://genetics.mgh.harvard.edu/sheenweb/>). 2×10^5 protoplasts were transfected with indicated constructs and incubated overnight in a 96-well microtiter plate before LUC activity was measured (Li et al., 2005). One millimolar luciferin was added to protoplasts and the materials were kept in dark for 6 min to quench the fluorescence. Relative LUC activity was measured using a Modulus microplate luminometer (Turner Biosystems). Each data point consisted of 3 replicates and 3 independent experiments were performed for each assay. *t* test was performed to determine statistic significance of differences at $P < 0.01$.

Expression and purification of recombinant rLecRK-b2 protein

The cDNA fragment (72 – 1971 bp) was amplified with primers listed in Table 1 and cloned to pCold TF vector. rLecRK-b2 was expressed as described on manufacturer's instructions (<http://www.takara-bio.com/>) and purified as described previously (Nishiguchi et al., 2002).

In vitro assay of recombinant proteins for kinase activity

The protein kinase activities were assayed by the method described previously (Schulze-Muth et al., 1996). The phosphorylation reaction was allowed to proceed at 25°C for 1 h. ^{32}P -labeled proteins were precipitated with 25% trichloroacetic acid, fractionated by 8% SDS-PAGE and autoradiographed.

RESULTS

LecRK-b2 localizes to plasma membrane

LecRK-b2 gene has a translated region of 1971 bp, encoding a protein of 656 amino acids. The prediction result

of SignalP 3.0 Sever (<http://www.cbs.dtu.dk/services/SignalP/>) shows that the predicted protein has an N-terminal signal peptide (amino acids 1-24) and a transmembrane domain (amino acids 278-301). The protein features on PlantsP (<http://plantsp.genomics.Purdue.edu/html/>) identified a legume lectin domain (amino acids 27-248) and a protein kinase domain (amino acids 334-615). To investigate the subcellular localization of the LecRK-b2, the full-length LecRK-b2 cDNA under the control of a 35S cauliflower mosaic virus (CaMv) promoter and with the C-terminal GFP tag was transformed into wild type Arabidopsis. T2 lines were used for GFP observation. The representative pictures were shown (Figure 1). The conformity result of fluorescence image and bright field image showed that GFP protein was absent in cell walls but mostly in plasma membrane after the root cells were plasmolyzed in 0.4 M mannitol. This indicates that LecRK-b2 encodes a membrane protein.

LecRK-b2 lectin domain can form homodimer in yeast

LecRK-b2 is a membrane protein; it is not suitable for normal yeast 2 hybrid systems. So the predicted transmembrane domain was truncated and the remaining N terminal (lectin domain, designated LLecrk-b2) and C terminal (kinase domain, designated KLeCRK-b2) was used for yeast 2 hybrid assay. Histidine auxotrophy assays (Figure 2A) showed that the yeast harboring pBridge-LLecrk-b2 and pGADT7-LLecRK-b2 could grow on histidin deficient SD medium, while the yeast harboring pBridge-KLeCRK-b2 and pGADT7-KLeCRK-b2 could not grow on histidin deficient SD medium. To reconfirm the protein-protein interactions, colony-lift filter assay and liquid culture assay (using chlorophenol red- β -D-galactopyranoside as substrate) was used. As shown in Figures 2B and 2C, the yeast harboring pBridge-LLecrk-b2 and pGADT7-LLecRK-b2 has weak β -galactosidase activity compare with positive control. In contrast, the yeast harboring pBridge-KLeCRK-b2 and pGADT7-KLeCRK-b2

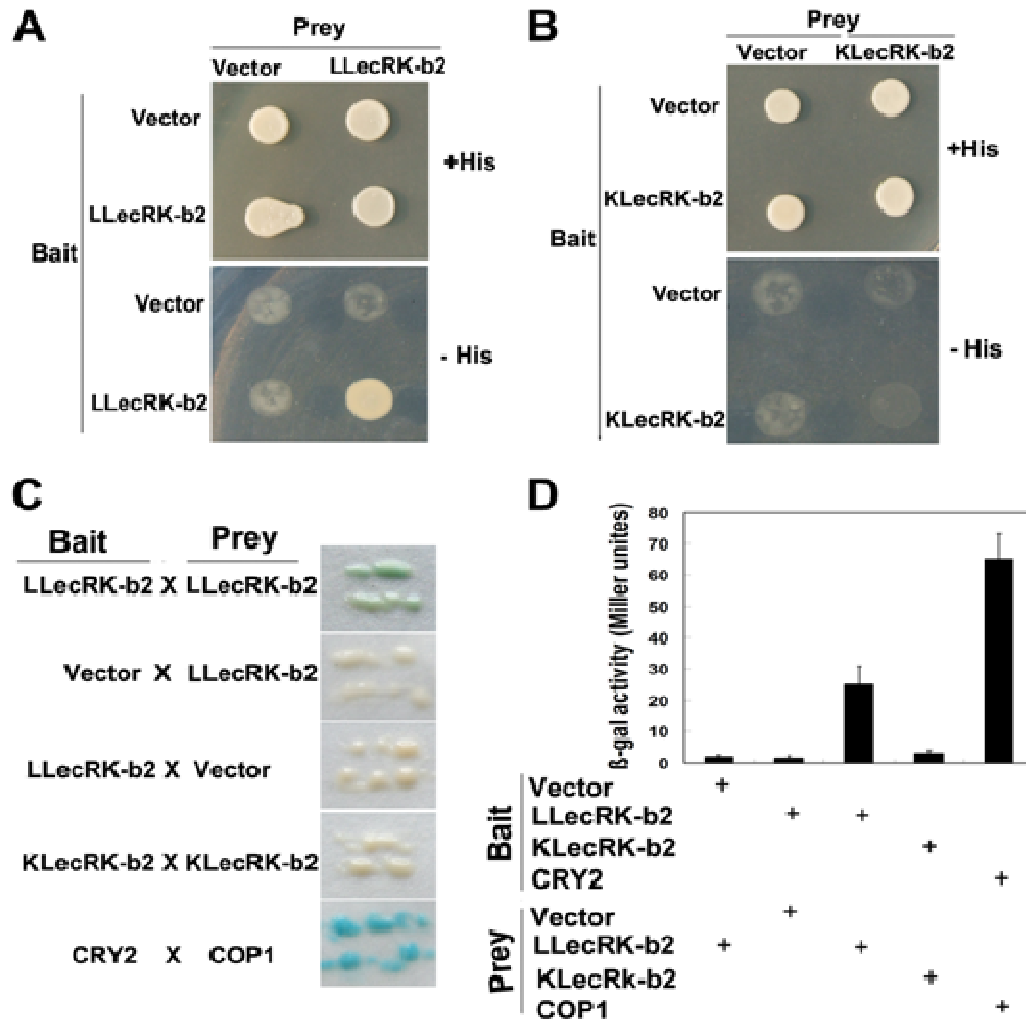

Figure 2. LecRK-b2 lectin domain can form homodimer. A. Histidine auxotrophy assays showing the interaction between LLecRK-b2 and LLecRK-b2, and the lack of interaction between KLecRK-b2 and KLecRK-b2. B. The galactosidase activity was assayed by the colony-lift method and observed by blue color development. The positive control shows the interaction of the CRY2 and COP1. C. Liquid culture assay using CPRG (chlorophenol red- β -D-galactopyranoside) as substrate. D. The data shown are representative of three independent experiments.

exhibit only background β -galactosidase activity. These results indicate that lectin domain LLecrk-b2 can interact with itself to form homodimer in yeast, but there is lack of interaction between the kinase domain of LecRK-b2 proteins.

Lectin domain is required for dimerization of LecRK-b2 *in vivo*

For further determination of the functional model of LecRK-b2 in plant, split LUC technology was employed. The extracellular domain (included transmembrane domain), intracellular domain (included transmembrane domain) and the full length LecRK-b2 were cloned to the CLUC and NLUC vector (Figure 3A). Quantification of LUC activity

in protoplasts expressing split LUC constructs (Figure 3B) showed that the NLecRK-b2-NLecRK-b2 interaction resulted in a significant increase in LUC activity. Similarly, co-expression of FLecRK-b2:NLUC with FLecRK-b2:CLUC in *Arabidopsis* protoplasts also resulted in strong complementation of LUC activity. In contrast, CLecRK-b2:NLUC coexpressed with CLecRK-b2:CLUC construct showed only background level LUC activity.

The autophosphorylation activity of Lecrk-b2

To test the autophosphorylation activity of LecRK-b2, gene for recombinant protein, rLecRK-b2 (Asp²⁵-Gly⁶⁵⁶), was expressed in *E. coli*. A methionine residue at the N-terminus was added to the original sequence. The predic-

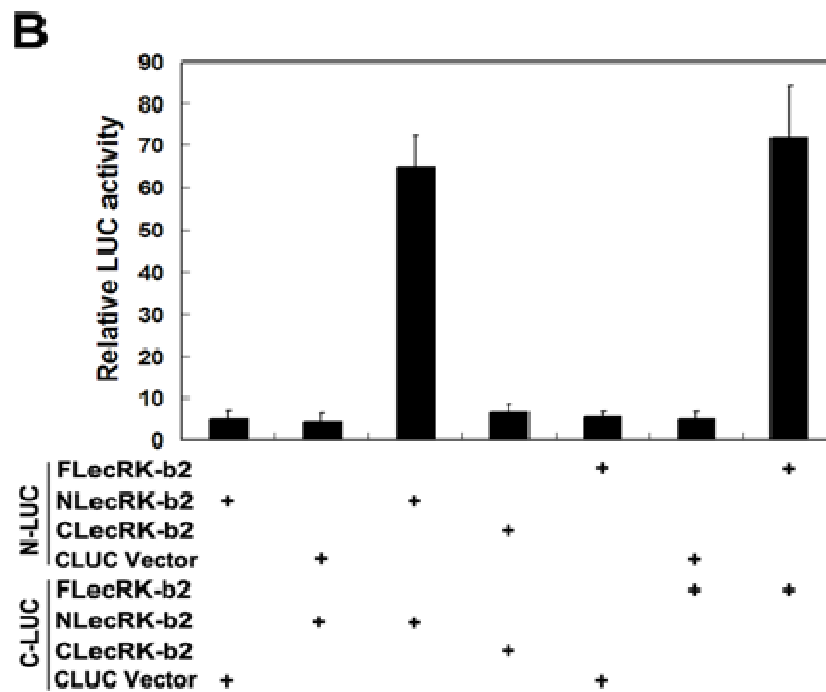
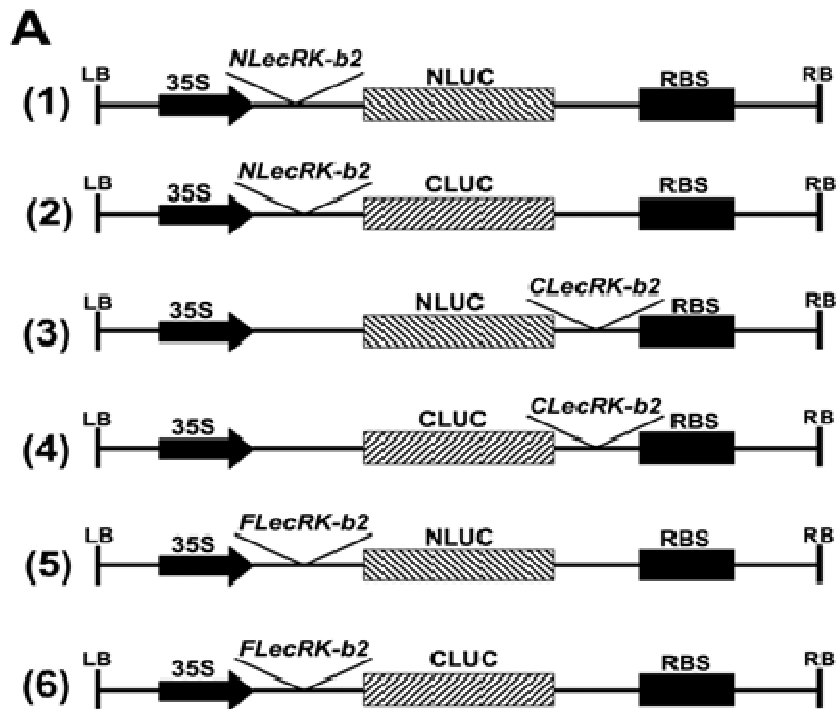

Figure 3. Split luciferase (LUC) complementation assay. A. split LUC vectors construct for complement assay; (1) and (2), NLecRK-b2 was cloned to the N-terminal of NLUC and CLUC; (3) and (4), CLecRK-b2 was cloned to the C-terminal of NLUC and CLUC; (5) and (6), FLecRK-b2 was cloned to the N-terminal of NLUC and CLUC. RBS, Transcription terminator derived from the Rubisco small subunit gene. B. Quantification of LUC activity in protoplasts expressing the split LUC constructs NLecRK-b2:NLUC and NLecRK-b2:CLUC, CLecRK-b2:NLUC and CLecRK-b2:CLUC, FLecRK-b2:NLUC and FLecRK-b2:CLUC. NLecRK-b2:NLUC and CLUC, NLUC and NLecRK-b2:CLUC, FLecRK-b2:NLUC and CLUC, NLUC and FLecRK-b2:CLUC were used as control. The data shown are representative of 3 independent experiments.

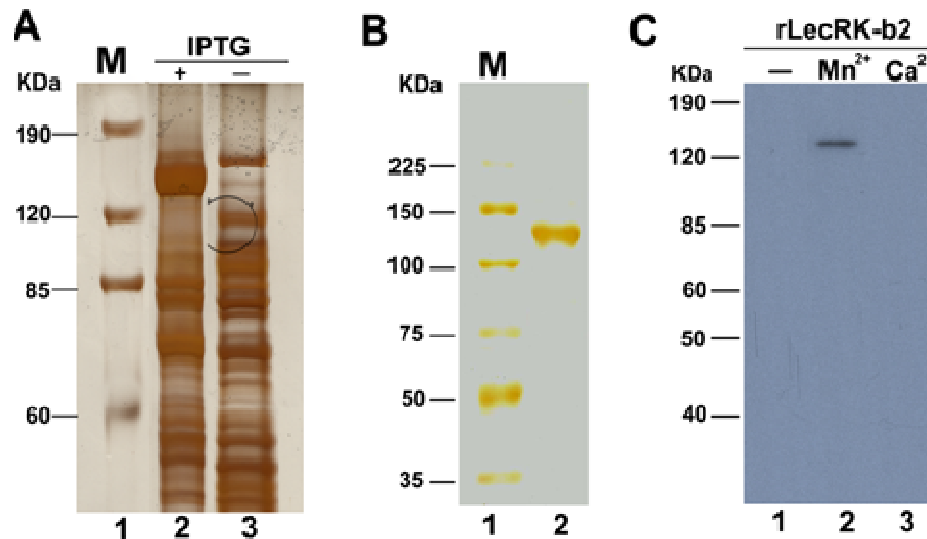

Figure 4. *In vitro* assay of recombinant proteins for kinase activity. A. Expression of recombinant rLecRK-b2 protein; lane 2, Protein expression inducing by 0.5 mM IPTG (Isopropyl β -D-1-Thiogalactopyranoside); lane 3, protein expression without IPTG. B. Purified recombinant rLecRK-b2 protein. In A and B the gel were stained with AgNO_3 . C. Assay for autophosphorylation of rLecRK-b2; 5 μg of the recombinant protein were used for phosphorylation assays with $[\gamma\text{-}^{32}\text{P}]\text{ATP}$. Divalent metal cations were added to the reaction mixtures; lane 1, 2 mM EDTA was added; lane 2, 10 mM MnCl_2 ; lane 3, 10 mM CaCl_2 .

ted molecular mass of rLecRK-b2 was 72 KDa. The expressed and purified recombinant protein on SDS-PAGE showed the roughly equivalent molecular mass to the predicted value (Figures 4A and 4B).

The phosphorylation activity of recombinant protein was assayed by using $[\gamma\text{-}^{32}\text{P}]\text{ATP}$ as a phosphate donor. rLecRK-b2 exhibited divalent metal cations dependent autophosphorylation activity (Figure 4C). When there were no free divalent metal cations (EDTA was added), there was no autophosphorylation activity. The autophosphorylation activity was detectable in the presence of Mn^{2+} . However, little activity was detected in the presence of Ca^{2+} .

DISCUSSION

GFP-LecRK-b2 fusion assays indicated that LecRK-b2 is a membrane protein. The transmembrane domain located between amino acids 278-301 maybe responsible for its subcellular localization. To date, many LecRks had been identified as membrane proteins, such as *Arabidopsis* protein LecRKA4.1 (Xin et al., 2009) and *Nicotiana benthamiana* protein NbLRK1 (Kanzaki et al., 2008). They play a major role in extracellular signal perception and also control a wide range of physiological responses in plants.

Legume lectins had been demonstrated to form oligomers in plants (Hamelryck et al., 1996). The lectin domain of LecRK-b2 has high sequence identity to legume lectin. It is no doubt lectin domain of LecRK can form dimer. The

yeast 2 hybrid results confirmed this hypothesis. It also indicated that this dimerization was ligand independent. Split luciferase complementation assays further confirmed the yeast 2 hybrid results and suggested that lectin domain was responsible for the dimerization of LecRK-b2 protein in plant.

Furthermore, the recombinant LecRK-b2 protein exhibited Mn^{2+} autophosphorylation activity. A similar requirement for metal ions for phosphorylation activity has been reported. For example, RLK5 from *Arabidopsis* and pNLPk from lombardy poplar autophosphorylated in the presence of Mn^{2+} . Mn^{2+} may also contribute to the homodimerization (Horn and Walker, 1994; Nishiguchi et al., 2002), because lectin oligodimer formation is divalent metal ion dependent (Hamelryck et al., 1996).

ACKNOWLEDGMENTS

This research was supported by the grants from National Natural Science Foundation of China (30600368; 30770-200;30871325).

REFERENCES

- Baer K, Al-Hasani H, Parvaresh S, Corona T, Rufer A, Nolle V, Bergschneider E, Klein HW (2001). Dimerization-Induced Activation of Soluble Insulin/IGF-1 Receptor Kinases: An Alternative Mechanism of Activation. *Biochemistry*, 40: 14268-14278.
- Barre A, Herve C, Lescure B, Rouge P (2002). Lectin Receptor Kinases in Plants. *Crit. Rev. Plant. Sci.* 21: 379-399.
- Chen X, Shang J, Chen D, Lei C, Zou Y, Zhai W, Liu G, Xu J, Ling Z,

- Cao G, Ma B, Wang Y, Zhao X, Li S, Zhu L (2006). A B-lectin Receptor Kinase Gene Conferring Rice Blast Resistance. *Plant J.* 46: 794-804.
- Chen H, Zou Y, Shang Y, Lin H, Wang Y, Cai R, Tang X, Zhou JM (2008). Firefly Luciferase Complementation Imaging Assay for Protein-Protein Interactions in Plants. *Plant Physiol.* 146: 368-376.
- Giranton JL, Dumas C, Cock JM, Gaude T (2000). The Integral Membrane S-locus Receptor Kinase of Brassica has Serine/threonine Kinase Activity in a Membranous Environment and Spontaneously Forms Oligomers in Planta. *PNAS*, 97: 3759-3764.
- Hamelryck TW, Dao-Thi MH, Poortmans F, Chrispeels MJ, Wyns L, Loris R (2008). The Crystallographic Structure of Phytohemagglutinin-L. *J. Biol. Chem.* 271: 20479-20485.
- Horn MA, Walker JC (1994). Biochemical Properties of the Auto-phosphorylation of RLK5, a Receptor-like Protein Kinase from *Arabidopsis thaliana*. *Biochim. Biophys. Acta*, 1208: 65-74.
- Jiang G, Hunter T (1999). Receptor Signaling: When Dimerization is not Enough. *Curr. Biol.* 9: R568-R571.
- Kanzaki H, Saitoh H, Takahashi Y, Berberich T, Ito A, Kamoun S, Terauchi R (2008). NLRK1, a Lectin-like Receptor Kinase Protein of *Nicotiana benthamiana*, Interacts with *Phytophthora infestans* INF1 Elicitor and Mediates INF1-induced Cell Death. *Planta*, 228: 977-987.
- Kim YS, Lee JH, Yoon GM, Cho HS, Park SW, Suh MC, Choi D, Ha HJ, Liu JR, Pai HS (2000). CHRK1, a Chitinase-Related Receptor-Like Kinase in Tobacco. *Plant Physiol.* 123: 905-916.
- Liu H, Yu X, Li K, Klejnot J, Yang H, Lisiero D, Lin C (2008). Photoexcited CRY2 Interacts with CIB1 to Regulate Transcription and Floral Initiation in *Arabidopsis*. *Science*, 322: 1535-1539.
- Navarro-Gochicoa MT, Camut S, Timmers ACJ, Niebel A, Herve C, Boutet E, Bono JJ, Imbert A, Cullimore JV (2003). Characterization of Four Lectin-Like Receptor Kinases Expressed in Roots of *Medicago truncatula*. Structure, Location, Regulation of Expression, and Potential Role in the Symbiosis with *Sinorhizobium meliloti*. *Plant Physiol.* 133: 1893-1910.
- Nishiguchi M, Yoshida K, Sumizono T, Tazaki K (2002). A receptor-like Protein Kinase with a Lectin-like Domain from Lombardy Poplar: Gene Expression in Response to Wounding and Characterization of Phosphorylation Activity. *Mol. Genet. Genomics*, 267: 506-514.
- Riou C, Herv C, Pacquit V, Dabos P, Lescure B (2002). Expression of an *Arabidopsis* Lectin Kinase Receptor Gene, *lecRK-a1*, is Induced during Senescence, Wounding and in Response to Oligogalacturonic Acids. *Plant Physiol. Biochem.* 40: 431-438.
- Sasabe M, Naito K, Suenaga H, Ikeda T, Toyoda K, Inagaki Y, Shiraishi T, Ichinose Y (2007). Elicitor-responsive Lectin-like Receptor Kinase Genes in BY-2 Cells. *Mitochondrial DNA* 18: 152-159.
- Schlessinger J (2002). Ligand-Induced, Receptor-Mediated Dimerization and Activation of EGF Receptor. *Cell* 110: 669-672.
- Schulze-Muth P, Irmiler S, Schroder G, Schroder J (1996). Novel Type of Receptor-like Protein Kinase from a Higher Plant (*Catharanthus roseus*). cDNA, Gene, Intramolecular Autophosphorylation, and Identification of a Threonine Important for auAto and Substrate Phosphorylation. *J. Biol. Chem.* 271: 26684-26689.
- Shimosato H, Yokota N, Shiba H, Iwano M, Entani T, Che FS, Watanabe M, Isogai A, Takayama S (2007). Characterization of the SP11/SCR High-Affinity Binding Site Involved in Self/Nonself Recognition in *Brassica* Self-Incompatibility. *Plant Cell*, 19: 107-117.
- Spaargaren M, Defize LH, Boonstra J, de Laat SW (1991). Antibody-induced Dimerization Activates the Epidermal Growth Factor Receptor Tyrosine Kinase. *J. Biol. Chem.* 266: 1733-1739.
- Clough SJ, Bent AF (1998). Floral Dip: a Simplified Method for *Agrobacterium*-mediated Transformation of *Arabidopsis thaliana*. *Plant J.* 16: 735-743.
- Wan J, Patel A, Mathieu M, Kim SY, Xu D, Stacey G (2008). A lectin Receptor-like Kinase is required for Pollen Development in *Arabidopsis*. *Plant Mol. Biol.* 67: 469-482.
- Wang H, Peters GA, Zeng X, Tang M, Ip W, Khan SA (1995). Yeast Two-hybrid System Demonstrates that Estrogen Receptor Dimerization Is Ligand-dependent in Vivo. *J. Biol. Chem.* 270: 23322-23329.
- Xin Z, Wang A, Yang G, Gao P, Zheng ZL (2009). The *Arabidopsis* A4 Subfamily of Lectin Receptor Kinases Negatively Regulates Abscisic Acid Response in Seed Germination. *Plant Physiol.* 149: 434-444.