

Full Length Research Paper

Application of Fuzzy-neural networks in multi-ahead forecast of stock price

Gholamreza Jandaghi^{1*}, Reza Tehrani², Davoud Hosseinpour³, Rahmatollah Gholipour⁴ and Seyed Amir Shahidi Shadkam⁴

¹Faculty of Management, Qom College, University of Tehran, Iran.

²Faculty of Management, University of Tehran, Iran.

³Faculty of Management, Allameh Tabataba'i University, Tehran, Iran.

⁴Faculty of Management, University of Tehran, Qom Campus, Qom, Iran.

Accepted 5 February, 2010

Today, investment by purchasing stock-share constitutes the greater part of economic exchanges of countries and a considerable amount of capital is exchanged through stock markets in the whole world. National economies are strongly influenced by the operation of stock markets; in addition, stock market as an available means for investment is of special importance for both investor and the receiver of investment. The most important part of this business is to obtain more profits through estimating future stock prices. This research with a probe in a sample of the whole population of the study involves the data and financial record of SAIPA auto-making company which is a member of Iranian stock, aims at the prediction of stock price. The prediction was done by the two linear and nonlinear models for one ahead and multi ahead in stock price by using exogenous variable of stock market cash index, and the results show the preference of nonlinear neural-Fuzzy model to classic linear model and verify the capabilities of Fuzzy-neural networks in this prediction.

Key words: One-ahead forecast, multi-ahead forecast, ARIMA linear model, neural networks, Fuzzy-neural model.

INTRODUCTION

The ability to predict the stock price to meet the fundamental needs of investors and market-makers for gaining more benefits is a memorable subject; this issue has attracted lots of audiences among the economic societies. Stock markets are influenced by many factors and this feature has created a high unreliability in this field. Price changes is a small index of the whole market data, and as financial markets are always tied with social events, by only considering price schemes we can not reach a suitable prediction in the stock price. Researchers have used a variety of means and models for these purposes. Among them we can mention technical and empirical methods and predictions in time series and methods based on intrinsic value of stock share and models based on artificial intelligence in the derivation of dominative patterns of the stock. From 1943, researches were shaped by Mc.Culloch and Walter

Pitts's searches on the simulation of every mathematical and logical equations computation. Firstly, in 1988, Helber White introduced the usage of neural networks in economic predictions. In these studies, the value of neural networks in the prediction of nonlinear models was introduced, and these techniques provide ability to decode the stock market (White, 1993). Kamiyo et al. (1990) used the prediction ability of a simple neural network which was equal to the most advance economy assessment models, to identify stock price patterns and predict stock market behavior (Kamiyo et al., 1990). In 1990, some researchers called Kimot T., Asakawa K., Yoda M. and Takeoka M. introduced the stock market prediction system by the use of neural networks. In that study they maintained that nonlinear learning and neural network's high ability have unique features in contrast to expert systems (Kimot et al., 1990).

In 1997, Raman Lawrence, using neural networks in a research attempted to predict stock prices. In this research the usage of neural networks in prediction is investigated and neural networks, with the pattern

*Corresponding author. E-mail: jandaghi@ut.ac.ir.

identification and discovery capabilities in non linear and chaotic systems, where assessed with more precision and more efficiency. The operations of common techniques in the market like technical analysis, fundamental analyses and regression techniques were compared to neural networks operations. Lawrence (1997) investigated the Efficient Market Hypothesis (EMH) with Artificial Neural Networks (ANN) and Chaos theory. Birgul et al. (2003) used neural networks attempted to predict Istanbul stock exchange market index value. In that research they investigated the results of different kinds of neural networks and classic method prediction, and the results show the preference of neural models to linear models and the other result was the suitability of feed-forward networks for one ahead forecast stock price. Azar and Fsar (2006) modeled the prediction of stock price by Fuzzy-neural networks approach. In this research neural networks and ARIMA models of price data were investigated and neural networks models showed unique properties of quick convergence, high precision, strong ability of function approximation, and in operation criteria they showed noticeable superiority in prediction. Stock holders usually use technical and fundamental analysis or a combination of these two. Technical analyses or chartists are looking for the historical patterns of stock price to predict its future changes. Fundamental analyses which are more common include the evaluation of a company by analyzing and interpreting the major influencer factors of economy, industry and company. Among the major parts of basic analyses is the assessment of financial status and company operation.

Artificial neural networks are intelligent systems which are inspired by the brain. These systems with unique properties such as the ability to learn, generalization and resistance against error can be suitable candidates for predictions in an environment with very complex logic. They do not equal the biological brain, however from two view points, they were similar, one similarity is compounding from individual blocks and another is relation between compounds that apply by networks (Hagan et al., 1996).

The purpose of this study is to drive a model based on Fuzzy-neural networks for the prediction of stock price in exchange, and this research will seek to compare the prediction ability in different time intervals by means of Box Jenkins method in Autoregressive Integrated Moving Average (ARIMA) model. The prominent feature of this study is the ability to do multi-ahead predictions which are seldom attended to in previous studies.

MATERIALS AND METHODS

Prediction in stock exchange

Contrary to fundamental approach which is based on stock and sale interests, economic growth rates, governmental rules and regulations, the chartists believe that the assessment of the intrinsic

value of any stock share is not easy, but previous prices reflect the future prices, so the study of previous records of price can be a great and influential help in determining the future price (Jones, 2003).

In the beginning of 20th century, Dow Theory was established, and was later known as modern technical analysis. In the beginning, Dow's theory was not a complete compound but it was gradually completed by assembling the components of Charles Dow's writings during years, and William Hamilton developed it for the prediction of market changes. The following are Dow's thoughts which were the primary principles of his theory.

1. Price represents all data.
2. Price changes are not completely accidental.
3. What has happened (price backgrounds) is much more important than its reason (why it has happened) (Stephen et al., 1998).

From 1970 by the publication of the first studies by Eugene Fama, the American economist, there appeared many debates about the concept of efficient market known as Efficient Market Hypothesis (EMH) in scientific meeting.

According to studies, three kinds of efficient markets are introduced which are classified according to the efficiency of market. A market is called efficient if abnormal and anomalous interest is not gained by means of the data existent in the market. He classified the efficient market hypotheses to three different levels; in each of these three levels the prices completely reflect the data of that level. The three levels introduced by Fama for efficient stock market involve weak, half strong, strong and efficient forms (Fama, 1969; Jones, 2003).

Stock market information in the research is classified according to this hypothesis, and different variables which are taken from common indexes in the market are used. Among important indexes are the total return index (TEPIX) in market that shows the whole market price change and is computed as weight average and involves the stock share of all the companies accepted in stock, and in the case the company's symbol is closed or is not traded for some time, the last trade price will be included in the index. The number of stock shares published by the companies is the criterion for weighting in that index. Another important index is cash efficiency and price that in addition to price apply cash dividend on it. This index was added to stock index in 1998 with base equal to the TEPIX. Cash efficiency index is a reflection of the general status of cash dividend paid by the companies and it is obtained by the division of total return index by cash efficiency and price index.

ARIMA nonlinear model

These models are opposite to structural models that are naturally multivariable and expressing the changes in one variable by changes in current and past amounts in other explanatory variables. Time series models are not only founded on theory, but they try to express experientially the features related to observed data. An important set of these models are ARIMA models family.

Gorge Box and Gwilym Jenkins were the first persons who offered a method for estimating these models in 1976. Their method is a practical one which includes four steps of transformation and pre-processing, identification, estimation and diagnostic checking. This method mostly uses the autocorrelation coefficient and partial autocorrelation coefficient (Neter et al., 1992).

One of the problems in ARIMA linear models with Box Jenkins's method is lack of the application of the model on nonstationary time series and this feature leads to the great preparation of time series. Among other disadvantages, we can mention the wide stages and limitation in the extraction of a model with expected precision in prediction. These models are restricted to the diagnosed pattern,

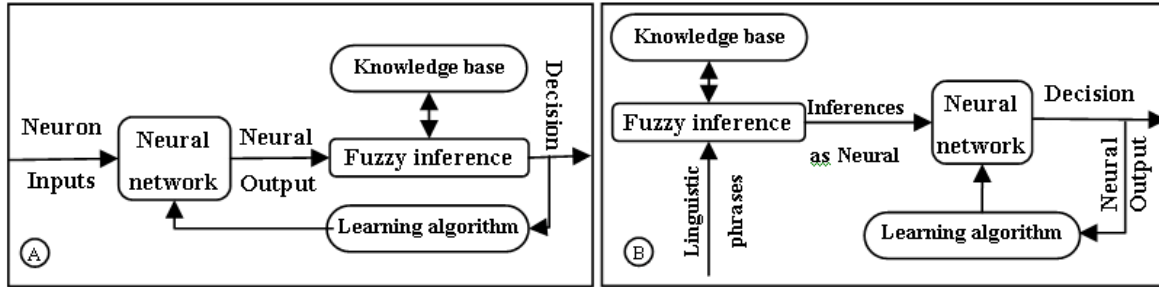

Figure 1. The basic structure of the two types of Fuzzy-neural systems.

Table 1. The comparison between neural networks and Fuzzy inferential systems.

Neural networks	Fuzzy inference systems
Prior rule-based knowledge cannot be used	Prior rule-based can be incorporated
Learning from scratch	Cannot learn (use linguistic knowledge)
Black box	Interpretable (if-then rules)
Complicated learning algorithms	Simple interpretation and implementation
Difficult to extract knowledge	Knowledge must be available

Ref: Abraham, 2001.

and occasionally the disorder or change in social structures that have direct influence on cause and effect of markets and economic routines in line with society, and may lead to the inability of linear models in estimating the suitable prediction. Their advantage is the explicit arithmetic pattern in the model that facilitates understanding the model for human being.

Fuzzy inference systems

Fuzzy logic offers a means for working with vague features. Fuzzy logic is an explicit way for linking the input space to output space. Fuzzy inference system can utilize the experience and knowledge of an expert by means of the Fuzzy inference rules offered in if-then forms. Fuzzy inference processing includes five steps: input fuzzification, exertion of Fuzzy operators, usage of inference methods, assembling all the inputs and defuzzification.

For gaining a suitable inference system it is necessary for the researchers to study in that subject and express it in a symbolic form completely, correctly and comprehensively. Unavoidably, Fuzzy inferential systems are moving toward deficiency because, although the experts are not willing to mention, the necessary knowledge for these systems is not available well, in addition, expressing subjects to the knowledge correctly and symbolically is very difficult (Nishina et al., 1997).

Compounding artificial neural networks with Fuzzy inferential system

The goal is a learning system to transfer professional behavior to Fuzzy rules. Gaining more information will lead to deeper understanding by brain and finally greater Fuzzy rules for achieving transforming information to rules. Artificial neural networks and Fuzzy models are used in many practical fields, and each one has advantage and disadvantage. Consequently with successful

compound of these two methods, today, Fuzzy-neural networks modeling is applied and used. Fuzzy-neural networks employ Fuzzy understanding system and the ability for neural learning. So, Fuzzy-neural system is able to model the unreliability and inner lack of precision of the data due to using the learning ability of Fuzzy-neural networks. Performance of systems is influenced by the domain of the problem and comparison to mere neural networks, it yields better results. Another advantage of Fuzzy-neural networks to mere neural network system is its inferential ability by means of logical rules in specific states. Depending on the type of the inferential system in use and sequence of structure, the unified Fuzzy-neural system can be divided into different types (Abraham, 2001). Figure 1 shows the approaches of the two inferential systems. Learning algorithms of neural networks are used for the identification and improvement of Fuzzy inferential system indexes. One important aspect for the system is to offer more precise interpretations about "if-then" Fuzzy rules, because Fuzzy system's principle is translating the vague scientific concepts (Jang and Sun, 1995). For a better comparison between neural networks and Fuzzy system, some of their major differences are given in Table 1.

Adaptive Neuro-Fuzzy inference system (ANFIS)

One of the most important Fuzzy systems is the adaptive Fuzzy neural inference systems (ANFIS). In such systems, the inference Fuzzy system uses neural networks to compensate for the weak points of Fuzzy reasoning. Their major advantage is that they can use neural networks learning ability, and prevent the expensive consumption of time for adjusting the rules of inferential motor in the Fuzzy reasoning system. In practice, there is no restriction in the functions of adaptive networks-nodes, unless they need to be derivative. The only structural limitation of network shapes is their being feed-forward. In contrast to these minor limitations, adaptive networks usage has increasingly and widely developed in practical fields. Below a class of adaptive networks was investigated which

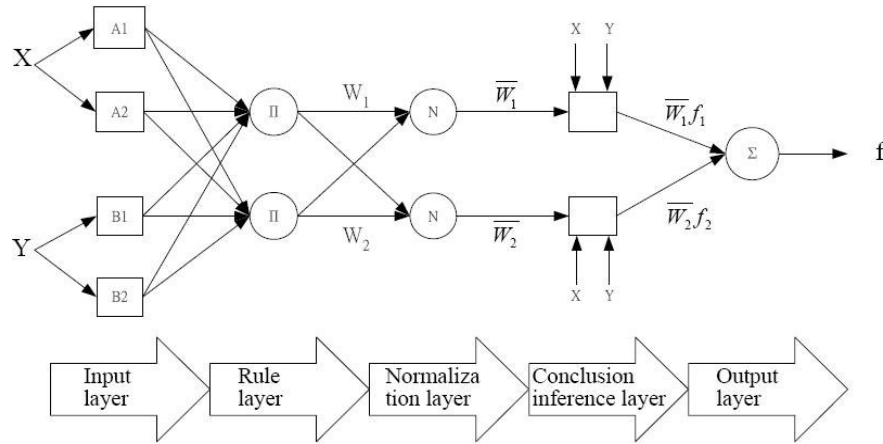

Figure 2. Structure of an Adaptive neural network.

are practically equivalent to Fuzzy inferential systems, with a structure similar to Figure 2 (Jang, 1993). Imagine, there is Fuzzy system which includes two input variables and one output variable and the following rules are the two Takagi Sugeno's if-then rules in it.

Rule

one: *if x is A₁ and y is B₁ then f₁ = p₁.x + q₁.y + r₁*

Rule

two: *if x is A₂ and y is B₂ then f₂ = p₂.x + q₂.y + r₂*

The ANFIS layers and nodes are defined as the following:

First layer: every node in this layer is a square node with a node function. $O_i^1(x) = \mu_{A_i}(x)$, so X is the input to *i*th node and A_{*i*} is the linguistic label (small, large, medium) suitable for this node function. In other words, O_i^1 is the membership function and it specifies a degree of membership for X in A set. Usually, $\mu_{A_i}(x)$,

bell shaped function and Gaussian function with a maximum amount of 1 and a minimum amount of 0. When their parametric values change, the shapes of function change accordingly and different forms are devoted to membership function in this layer. Parameters in this layer are as premise parameters and they are also known as left hand side parameters (LHS) (Jang et al., 1997).
 Second layer: Every node in this layer is presented like circle with a product sign (Π) which yields the input signal coefficient as product.

$$O_i^2(x) = \mu_{A_i}(x) \times \mu_{B_i}(x) \tag{1}$$

Third layer: every node in this layer is a circle with N label. In this layer the ratio of *i*th rule's firing strength to the sum of all the amounts of the previous layer's Fuzzy rules' firing strength is calculated:

$$O_i^3(x) = \bar{w}_i = \frac{w_i}{w_1 + w_2} \quad ; \quad i = 1, 2 \tag{2}$$

The output of this layer is the normalized firing strength. Forth layer: Every node in this layer is a square with a function like the following:

$$O_i^4(x) = \bar{w}_i f_i = \bar{w}_i (p_i x_1 + q_i x_2 + r_i) \tag{3}$$

In which \bar{w}_i is output of the forth layer and $\{p_i, q_i, r_i\}$ are the parameters of the set. They are also known as right hand side parameters (RHS). The parameters of this layer are considered as constant. One suitable way for determining the constant parameters is the use of the least square error algorithm.

Fifth layer: the single node of this layer has Σ label which computes the total output of the sum of all input signals as follows:

$$O_i^5 = \sum_i \bar{w}_i f_i = \frac{\sum_i w_i f_i}{\sum_i w_i} \tag{4}$$

ANFIS uses past-propagation learning to compute premise (parameters related to membership function identification) and uses the estimation of error rate decline for priority of parameters (Jang, 1993).

Learning in Fuzzy-neural systems

The basic learning rule of adaptive networks is based on the gradient descent and chain rule, which was proposed by Werbos in the 1970's. However, due to the state of artificial neural network research at that time. Werbos' early work failed to receive the attention it deserved. In the following presentation, the derivation is based on the Jang's work (Jang, 1991a, 1991b) which generalizes the formulas in study of Rumelhart et al. (1986) and Whitley et al. (1996). Since the basic learning rule is based on the gradient method which is notorious for its slowness and tendency to become trapped in local minima, researchers such Jang Proposed a hybrid learning rule which can speed up the process substantially both the batch learning, the pattern learning and the pattern learning (Jang, 1993).

Here we proposed a hybrid learning rule which combines the gradient method and the least squares estimate (LSE) to identify

Table 2. Two passes in the hybrid learning procedure for ANFIS.

Components	Forward pass	Backward pass
Premise parameters	Fixed	Gradient descent
Consequent parameters	Least squares estimate	Fixed
Signals	Node outputs	Error rates

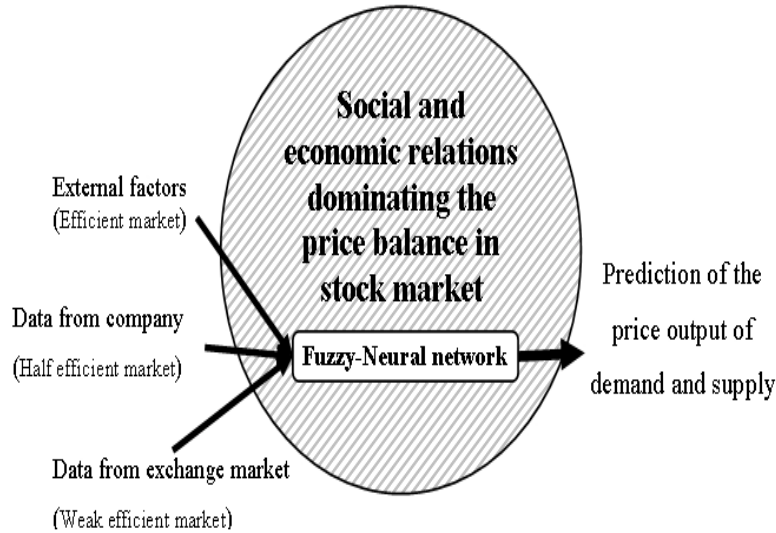

Figure 3. The conceptual model of the research (inspired from EMH theory).

parameters. It combines the gradient method and the least squares estimate to update the parameters in an adaptive network. Each epoch of this hybrid learning procedure is composed of a forward pass and a backward pass. In the forward pass, we supply input data and functional signals go forward to calculate each node output. In the backward pass, the error rates (the derivative of the error measure on each node output) propagate from the output end toward the input end, and the parameters in are updated by the gradient method. The comparison of the features of forward and backward pass is given in Table 2 in this form: First part: The input patterns are propagated and when it is assumed that logical parameter of the current cycle are considered as constant in training information, the prior optimum parameters are estimated by repeating the least square error average process. Second part: In the second part the patterns are repeated again and in this epoch, the past-propagation mechanism is used to correct the logical parameters while the prior parameters are held constant. This scheme is used as long as learning procedure is needed. For Fuzzy-neural systems with Mamdani influences the learning with superior techniques (past-propagation learning) and is applied for the purpose of training and modifications of the membership functions parameters (Jang, 1993; Kosko, 1993).

Statistical population of research

The population of this study is the stocks distributed in stock exchange of Iran. Stock price as the feature under investigation in the population is the subject of this study which originates from stock market activities and society of investors reactions to the recent revolutions. This study focused on the trend analysis and studied the stock behavior in an accepted company in stock market

and used a model to investigate the Fuzzy-neural network-s prediction ability.

METHODOLOGY OF THE STOCK PRICE PREDICTION MODEL

Figure 3 shows influences of the informational factors on stock price in exchange market according to efficiency market hypothesis that forms the conceptual model of this study. The purpose of this study is to create prediction model for stock price which select the most influential factor in weak efficient market, and use them by classical statistic methods and artificial intelligence to simulate the complex interactions in exchange environment.

Regarding the conceptual model presented in Figure 3, Fuzzy-neural device will be used for a simulation of complex interactions, estimation of stock price and linear modeling with use for investigating the Fuzzy-neural-s modeling ability. Software tools for prediction of stock price in both modeling method are presented below and collection and preparation of information is preformed by Access and Excel 2003 software.

1. Nonlinear Fuzzy-neural modeled by ANFIS adaptive network for non-linear model simulation, Matlab version 2007b software is used.
2. Linear ARIMA modeled by Box Jenkins techniques for linear model simulation, Eviews version 5.0 is used.

Case study of this article

With the help of some of stock exchange experts, we identified the companies accepted in Iranian stock exchange based on criteria

that has been required for prediction model and finally, after random selection of the names of some companies, the companies possessing primary qualifications was selected. As among classical statistic models suitable for the stock price prediction by price backgrounds, autoregressive and moving average models are applicable and the major model of research is based on Fuzzy-neural networks, it is clear that the requirements of these models are the discriminatory factors for selecting the sample (the company). Some of the required factors are having enough interchange events in stock market and having experience of steady stock exchange in consecutive days and with natural price scheme as well as access to company financial records during price derivation. Finally, regarding the election stages, SAIPA Company was selected form among the members of Iranian stock exchange organization. Time span of the study is from the beginning of the time that data banks of stock market organization presented price information together with exogenous variable of stock market. This information is available in time intervals from 2001/04/10 in database of Iranian stock exchange organization. In this study, regarding conceptual model, the research variables are classified as the following:

1. Previous records of the stock.
2. Previous records in stock market.

The major variable of this study which is used in time series is the last price of stock exchanged by SAIPA, and regarding preference in the usage of endogenous variables in the model, one data is selected as the most suitable from the data represented in weak efficient market (stock markets indexes). For exogenous variables, each stock records and stock market indexes in every opening of the stock hall are used, which are recorded from 2005/11/27 to 2008/05/25 with 490 records in official website of Iranian stock exchange. Regarding the conceptual model of the study its variables are classified as the following:

1. The major variable: The last traded price on board every day.
2. Variables from stock records: the amount of shares exchanged every day and the value of exchanged shares in every day.
3. Variables from stock market records: the total return index, the weight index of fifty superior companies, index of industry, the cash and price efficiency, the cash efficiency, the price index of fifty superior companies
4. The selected exogenous variables: value of exchanges, the amount of exchanges, total return index of the whole stock, index of industry, the weight index of fifty superior companies, price index of fifty superior companies and cash efficiency.

Investigation and preprocessing of data in input variables

The first step in using the model, is preparing the input data to take most advantages from statistical models and artificial intelligence. The price of stock usually undergoes changes beyond natural interactions of supply and demand. The cash dividends payable among stock holders and increase of capital through appropriation of stock or bonus stock and breaking of stock are some of the factors that directly affect the price of stock in exchange market, in other words they create the diluted prices (Jahankhani et al., 1995). The effect of dividend, after every phase of dividing the interest and decline of price, equals the amount of interest, and for modifying the price series the amount of the dividends interest is reduced from the pay-date and before according to the following formula:

The price after payment of dividends interest = The price before meeting – the dividends interest paid (5)

The effects of increasing capital on previous prices should also be

modified according to growth ratio, using the following formula:

$$P_2 = \frac{P_1 + \beta I}{1 + \alpha + \beta} \quad (6)$$

In which P_1 is the growth before capital increase, P_2 is the price after capital increase, I is the nominal value of each stock, β is the growth percentage from cash shared by stock holders and α is the percentage of the capital growth from deposits.

Interval investigation in exogenous variables

Application of exogenous variable increases model's inferential ability and the model uses the exogenous variable as the factor having regular and more stable rules in relation to the stock price itself and this feature offers more rule-governed predictions (in relation to predictions merely based on stock behavior experience). The best candidates should be investigated from the viewpoint of cross-correlation with intervals larger or equal to a day before in the exogenous variables during 2005 to 2008. It is apparent in social and economical interactions. Because every change in the variables in stock market does not show its effects completely at the same time and the best way of investigating the exogenous variables is through "cross-correlation". The results of this investigation for exogenous variables in time series during 2005/11/27 to 2008/05/25 (with 490 data) was the one day before of "cash efficiency index" with the best and largest correlation equal to 0.855.

Preparation of input data in nonlinear modeling with Fuzzy-neural systems

Input data should be normalized for analysis in neural networks, because input neurons should enter the network in equal scales because large data affect the importance of small data and cause error in weight distribution scheme. So in these networks we first prepare the input data to meet the needs of the model in use. But in Fuzzy-neural networks, depending on the architecture design, this issue may not be sensitive and complicated. In ANFIS Fuzzy-neural networks on which we had been focused for prediction and are among compound Fuzzy-neural systems, input structure transports the data through Fuzzy inference system.

So regarding the primary needs of Fuzzy systems, they should cover domain of variables, in fact this is the normalization of input data. But keep in mind that the second purpose of input data normalization is defining the limits of variables and in doing so, we let the system to know the upper and lower limits of the variables. In Fuzzy systems, this can be done by determining the upper and lower limits of Fuzzy systems, but the problem is that membership functions especially Gaussian and bell shaped functions are less sensitive to large numbers. So we normalize the input data in the last modified stock price series and exogenous variable of the cash index of market (Berry et al., 2004). For normalization of data we use the following formula:

$$Normalized \ data = \left(\frac{x_t - (x_{min} - |0.2 x_{min}|)}{(x_{max} + |0.2 x_{max}|) - (x_{min} - |0.2 x_{min}|)} \right) \quad (7)$$

In this formula a maximum increase of twenty percent and a minimum decline of twenty percent are taken into account to cover the probable domain change in prediction period. In this system normalization is carried out under the Fuzzy or linguistic variables and other normalization is carried out for the continuum of input

Table 3. Properties of one-ahead prediction by ANFIS in price series.

Criteria	375 observation	115 testing data
Prediction domain	one day-ahead forecast	one day-ahead forecast
MSE	1089	468.1
MAD	10.01	16.71
R-square	0.9952	0.9931

data into the Fuzzy system. The data included 490 data that are formed in daily periods for each appearance on the stock hall board and to be able to apply it, the existent data are divided with the ratio of one to three into 375 training data or model approximation and 115 testing data for checking the model.

The architecture of the network for prediction

Typology of the network includes number of the network layers, number of the outputs, type of the membership functions and linguistics variables which are of network properties. ANFIS networks have a known structure which has developed as in Figure 2. These networks include five layers. Among the architectural properties that should develop for the model, it can mention the number of input variables and linguistic variable and membership function's types. In neural networks, because the inner operation of the network is not clear, trial and error and experience is often used for identification of architecture. Unavoidably, many of the ANFIS models should be investigated with different topologist for attaining the optimum model. The model with minimal error indexes and maximize R-square is better model. The most important limitation is that with increasing the number of input variables the number of network parameters progressively increase. For testing the models in this study, the programming Matlab 2007b software is used for different input variable sets of time series in ANFIS system and reach to an optimum model. These variables constitute a schema which will introduce time series to the network and exogenous is the side variable that was selected in the cross-correlation analysis.

As in Fuzzy-neural networks, there is no specific arithmetic pattern for the estimation of parameters, the model identifies the coefficients by learning and forms new membership functions. As these parameter modifications are carried out in input/output membership functions, they cause the formation of nonlinear model for which the best learning is applied by hybrid method (Hagan et al., 1996). That identification of a suitable model is done through repetitive trials and experiments for different components of the architecture of ANFIS networks and for finding the suitable model for it, different models are tested by the use of ANFIS module implemented in Matlab software. On the other hand, regarding the demonstration in preference comparison of ANFIS Fuzzy-neural network operation to ARIMA linear model, series modeling data set and exogenous variable with equal interval times, thus is focused on to attain equal conditions for both of the models. So estimation of prediction model has attempted with 375 modeling data and 115 testing data. Different input variable set were identified and inserted in the series with a range of about 100 latter time intervals: as the following:

$$input = \{ts(t - a), ts(t - b), ts(t - c), \dots, cash\ efficiency(t - 1)\} \dots$$

$$: \{a, b, c, \dots\} \in Random[0,100]$$

(8)

For investigating our expectations from the model, two series of

prediction is carried out, one is the several days prediction in which the model predicts several future days by its current training that has been called multi-ahead forecast and the other one is the one day prediction in which the network employs modeling epoch training and uses the real data for the prediction of only one day after and was called one-ahead forecast. Neural model tries to minimize its errors in relation to favorite results. So the best model for one-ahead forecast is the one which has the least errors in its prediction for one day after by the use of the real data of previous days. While the best model for multi-ahead forecast is the one which has the least errors in its estimation of the price of next several days by the use of latter predicted data.

RESULTS

One day prediction

To select the best predictive model in this research, About 500 input variable sets in models were tested. The best ANFIS model was selected based on parameters set of input variables in regards to the best predictive performance indexes, as the following:

$$input = \{cash\ efficiency(t - 1), ts(t - 1)\} \tag{9}$$

ANFIS model with the input variables of the previous day's cash efficiency index $input\ 1 = cash\ efficiency(t - 1)$ and previous day stock price $input\ 2 = ts(t - 1)$ was able to forecast with determination coefficient 0.9971, by 375 primary modeling data for the whole range of 490 data. This prediction can be accounted for in conditions completely equal to one-ahead forecast in ARIMA model for same test data. Although the model uses real data in the test range, it does not improve learning and its parameters on test data. As the results and real criteria for prediction are shown in Table 3, SAIPA stock price prediction for the whole range of price time series (490 real data from 2005/11/27 to 2008/05/25) by the thought model in modeling data range (375 prior data). As can be seen from Table 3, the R-square of the training data is 0.9952 showing a good fit. When the model was tested on 115 testing data, it showed a reasonably good performance in prediction. Predicted stock price on testing data after denormalizing operation, is presented in a graph in Figure 4. This is called the first ANFIS model. The upper graph in Figure 4 shows the actual and forecasted graphs

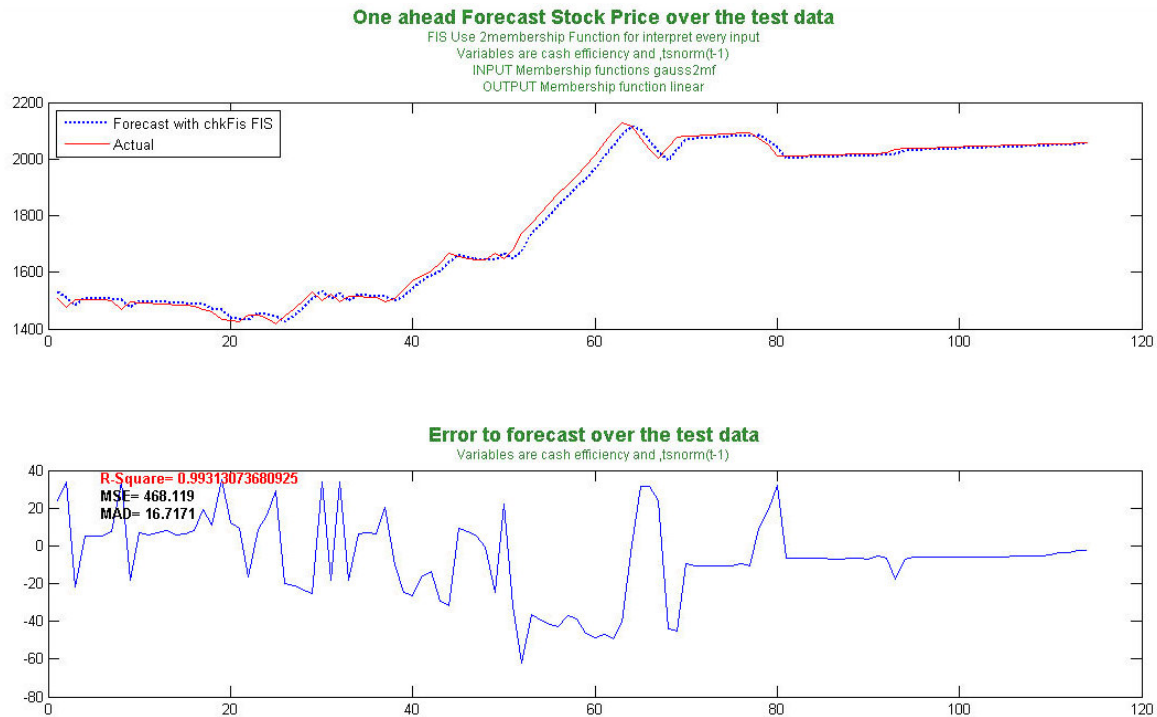

Figure 4. One-ahead prediction of the first ANFIS model in stock price of SAIPA.

Table 4. Properties of multi-ahead prediction by ANFIS in price series.

Criteria	375 observation	115 testing data
Prediction domain	375 days-ahead forecast	115 days-ahead forecast
MSE	13753	20564
MAD	82.51	120.33
R-square	0.9086	0.6982

over the test data. The solid line is the graph of the actual data and the dashed line shows the forecasted graph which seems reasonably good forecast. The lower graph shows the error of the forecast over the test data.

Multi-ahead prediction

One solution for multi-ahead forecast is training the network for such predictions, this means that the network predict its future range and then modify its coefficients according to estimated errors in future range which is beyond the domain of this study and needs a lot of probe and change in network structure.

The other solution is that ANFIS network estimate price at next day according to its existent structure with forecasted price on later period. To achieve this property, we investigated models with input variable set in 100 interval times by programming in Matlab software and ANFIS module. This program by applying the predictions

of itself in its input presented the ability for investigating the predictions of the several next days. The result of the investigation of multi-ahead prediction of different variable set in ANFIS model is the following:

$$input = \{cash\ efficiency(t-1), ts(t-1), ts(t-64)\} \tag{10}$$

In this variable set, the model was able to obtain the best multi-ahead prediction among the several investigated set, with deterministic coefficient in testing data equal to 0.908 and 0.698 in modeling data domain. The summary of the results of this model are illustrated in Table 4. 115 day-ahead prediction of SAIPA stock price based on the whole domain of price time series (490 real data from 2005/11/27 to 2008/05/25) by the trained model in modeling data domain (375 primary data) is illustrated in a graph in Figure 5 after demoralizing operation. It is necessary to mention that the reason for increase in

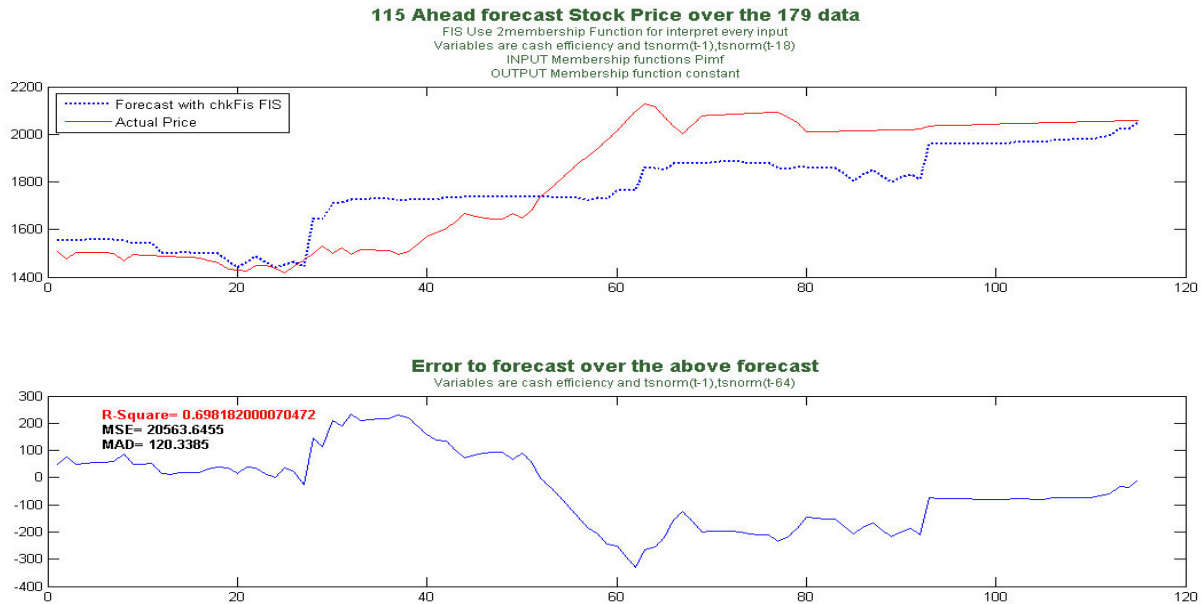

Figure 5. Multi-head prediction of the ANFIS model in stock price of SAIPA.

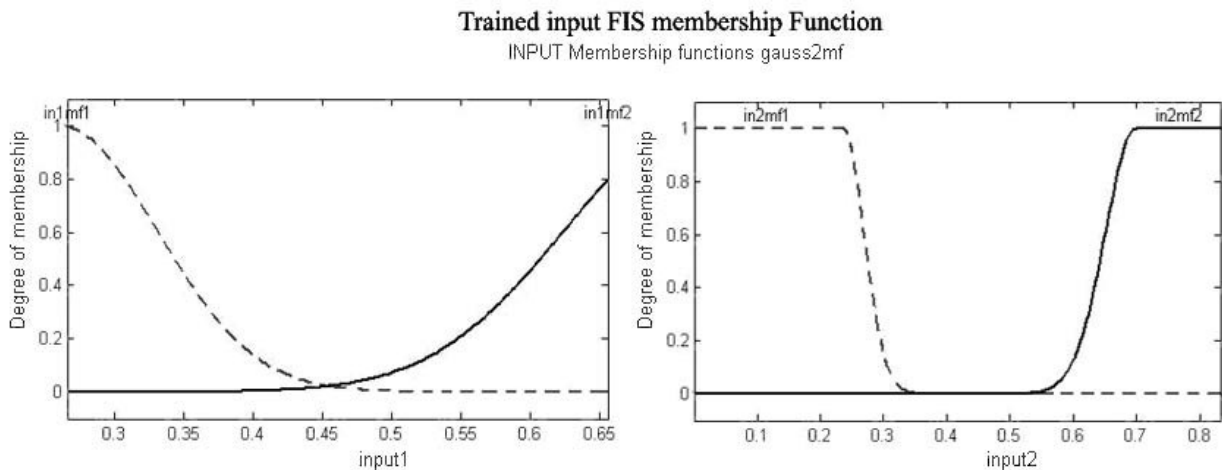

Figure 6. Membership functions of the first ANFIS model after training.

prediction domain to 179 is that input data includes 64 previous time interval of prediction domain. This is termed as the second ANFIS model. The upper graph in Figure 5 shows a weak fit for second ANFIS model rather than first model. The error of the forecast is seen in the lower graph of Figure 5. This means that the 115-ahead forecast has a weak performance.

Structural investigation of superior models in order to Inputs

The first model by receiving two inputs, stock price of previous day and cash index of previous day stock

market, became the best predictors of the current day among the tested models. This model is obtained from seven random input variable set in 100 latter time interval and six membership function for forming fuzzification structure in Fuzzy inference unit tested, such as: Gaussian, linear, triangular, trapezoid, sign, bell-shaped and slope functions. The second model achieved a better estimate in multi-ahead forecast with adding a new variable on prior input variable set. This variable (t-64) reduced the dependence of output on recent data and prepared the suitable data for predictions of the next several days. Figure 6 illustrates the input membership functions after training process in first Fuzzy-model with two variables and Figure 7 shows the input functions of

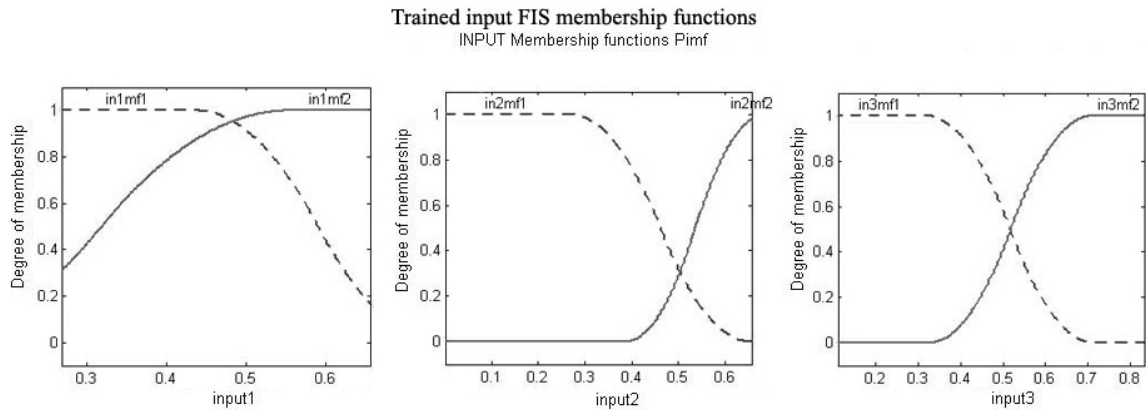

Figure 7. Membership functions of second ANFIS model after training.

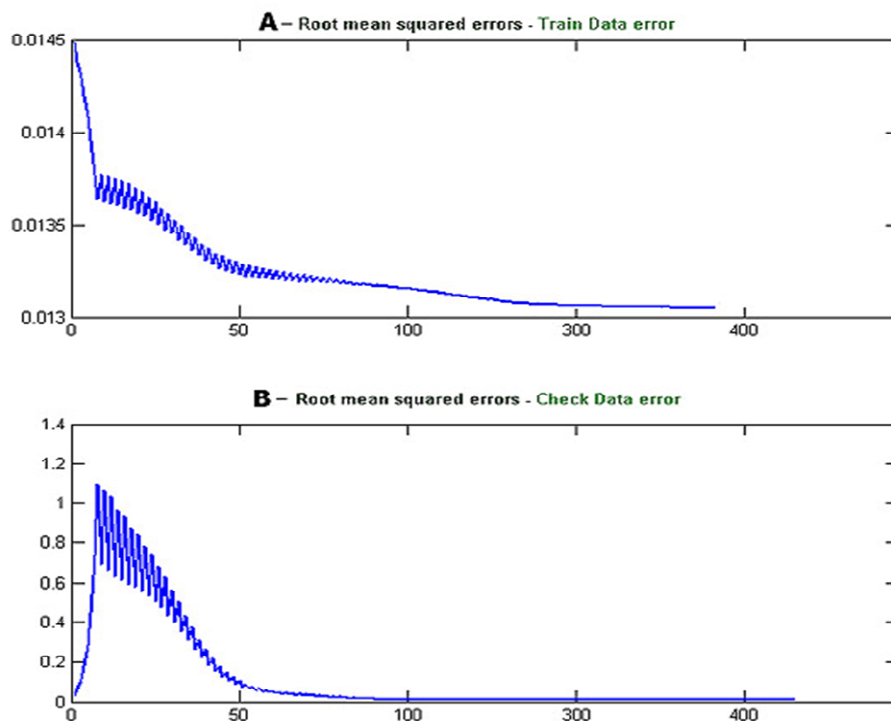

Figure 8. Training error in different epoch in A- training data, and B- testing data.

second ANFIS model after trained on 375 training data with the three input variable and two linguistic fuzzification variables.

Error amount in every training epoch of superior models

After every iteration model training, the model that receives the amounts from the beginning to the end of 371-day training domain and error amount of the model next epochs (training times of every input set) gets

improved. Error amount in training epochs in different sequences on first ANFIS model is illustrated in Figure 8a, and error amount in test data in different sequences is illustrated in Figure 8B.

Model testing and analysis

For making sure of model operation, the prediction by Box-Jenkins classic device was also investigated. We use both models for the same time periods and exogenous variables and compare the results of the two

Table 5. Prediction indexes in Linear and Fuzzy-neural models.

Models	Criteria	375 observations modeling data		115 observations testing data	
		One-ahead	375 day-ahead	One-day ahead	115 day-ahead
ARIMA	MSE	2900.51	76029.82	582.20	43239.82
	MAD	17.44	213.03	17.29	190.90
	R-square	0.9872	0.6646	0.9912	0.3500
ANFIS	MSE	1089	13753	468.1	20564
	MAD	10.01	82.51	16.71	120.33
	R-square	0.9952	0.9086	0.9931	0.6982

models according to the medium of the square of error (MSE), medium of the absolute deviation (MAD) and deterministic coefficient (R-square) criteria, to reach a better model.

Superiority of Fuzzy-neural model

For investigating the model ability to classical models, the most popular linear prediction model, the time series ARIMA technique of Box-Jenkins method is used. In ARIMA linear models, two kinds of one-ahead and multi-ahead predictions are presented. The only prediction model predicts the stock price of next day by real data of previous days, and the multi-ahead forecast model, according to the model properties, predicts in the test data, without using the real data, whereas every estimate apply for further forecast. the model driven from Box-Jenkins method employs two periodical autoregressive and two moving averages and exogenous variable of cash index of one prior day, like ARIMA (2,0,2), as the following:

$$y_t = \mu + \phi_1 y_{t-1} + \phi_2 y_{t-2} + \theta_1 u_{t-1} + \theta_2 u_{t-2} + v \times \text{Exogenous variable} \tag{11}$$

In which μ is the mean of price series and ϕ_i is autoregressive of the i^{th} period coefficient and θ_j is the moving average coefficient of j^{th} period and V is the coefficient of exogenous variable (cash efficiency index of one prior day).

As mentioned in result, ARIMA linear model are less efficient in multi-ahead prediction, because in these models, after autoregressive period in ARIMA models (in linear model of this research, t-2) and after that period under Fuzzy-neural input variables (in Fuzzy-neural models of this research, t-1, t64), the prediction moves constantly. This is also true about neural networks, with regard to the nature of stock price and its complexities. By the application of exogenous variables in linear ARIMA and non-linear Fuzzy-neural models, the multi-ahead predictions improved. The results of linear model

against the first Fuzzy - neural networks (one - ahead prediction section) and the second Fuzzy-neural networks (multi-ahead predictions section) are assembled in Table 5. Identification coefficient index which shows explanation ability of dependent variable of research by dependant variables) are more prominent in Fuzzy-neural models, while other prediction indexes such as medium of the Square error (MSE) or absolute prediction error average (MAD) posses less amounts in all types and domains of Fuzzy-neural networks' predictions. So the Fuzzy-neural models showed their superiority in stock price predictions.

DISCUSSION

In this research, future stock price in stock exchange was forecasted by cash efficiency index as exogenous role and time series of stock price with Fuzzy-neural and ARIMA models. After preparing data of occurring series, the results of accomplished modeling in linear and Fuzzy-neural model were investigated separately and in same conditions and then these were compared with the perspectives of one-ahead and multi-ahead prediction, and the superiority of the Fuzzy-neural models in these predictions was verified.

As mentioned in introduction, some researchers also developed the application of Fuzzy-neural network on prediction stock price, but rarely long-term forecast is considered. Most research is based on neural network and Fuzzy-neural model applying to prediction stock price. This research develops its scope to predicting multi-ahead forecast over all periods of test data by contributing exogenous variable from exchange market.

One reason for this superiority is neural networks learning ability, because regarding reality Fuzzy-neural networks gain, the current patterns of the stock price include: interactions and influence of exogenous variables from training data and using it. This feature of understanding stock status is like human brain and by using the experience of previous stock behavior attempts to predict its future behavior. Because of complexity in effecting elements on stock price in exchange, Fuzzy-neural intelligent networks along new developed com-

puters and magic software, performed more precision and rapidity. In these models, massive and complexity
914 Afr. J. Bus. Manage.

calculation for learning and improving stages could be discussed that likewise exist in advanced linear models such as ARIMA.

In addition, multi-days perditions by contributing cash efficiency index in model can verify ability of Fuzzy-neural networks and it presented similar results about stock shares of SAIPA auto-making Iranian company.

REFERENCES

- Abraham A (2001). *Neuro-Fuzzy Systems: State-of-the-Art Modeling Techniques, Connectionist Models of Neurons, Learning Processes, and Artificial Intelligence*, Springer-Verlag Germany, Jose Mira and Alberto Prieto (Eds.), Granada, Spain. pp. 269–276.
- Azar A, Afsar A (2006). Stock price prediction modeling with Fuzzy-neural network approach, *J. Trade Studies*, autumn, 40: 33-38.
- Berry Michael JA, Gordon Linoff (2004). *Data mining techniques: for marketing, sales, and customer relationship management*, 2nd ed. Wiley, pp. 232-250.
- Birgul Egeli, Meltem Ozturan, Bertan Badur (2003). Stock Market Prediction Using Artificial Neural Networks, *Proceedings of the 3rd International Conference on Business*, June 18-21, Hawaii. pp. 1-8.
- Fama Eugene F (1969). Efficient Capital Markets: A Review of Theory and Empirical Work. In: *J. Finance, Papers and Proceedings of the Twenty-Eighth Annual Meeting of the American Finance Association* New York, N.Y. December. 25(2): 383-417.
- Hagan MT, Demuth HB, Beale M (1996). *Neural network design*, PWS Publishing Company, Boston. p. 712.
- Jahankhani A, Parsaiyan A (1995). *Securities exchange*. First print, SAMT Publications. Tehran. Iran.
- Jang Roger JS (1991). Fuzzy modeling using generalized neural networks and Kalman filter algorithm". In *Proc. of the Ninth National Conference on Artificial Intelligence (AAAI-91)*, pp. 762–767.
- Jang Roger JS (1991). Rule extraction using generalized neural networks". In *Proc. of the 4th IFSA World Congress*, p. 82–86 (in the *Artificial Intelligence*).
- Jang JR (1993) ANFIS: adaptive-network based Fuzzy inference systems", *Department of Electrical Engineering and Computer Science, University of California, Berkeley, IEEE Trans. On Systems, Man and Cybernetics*, 23: 665-685.
- Jang Roger JS, Sun CT (1995). "Neuro-Fuzzy Modeling and Control", *The Proceedings of the IEEE*, 3(83): 378-406.
- Jang Roger JS, Chuen-Tsai Sun, Eiji Mizutani (1997). *"Neuro-Fuzzy and Soft Computing: A Computational Approach to Learning and Machine Intelligence"*, MATLAB Curriculum Series, Upper Saddle River, NJ, Prentice Hall.
- Jones Charles P (2003). "Investments: Analysis and Management", 8th Edition, translation in, Tehrani R., Noorbakhsh A., (2007). "Investment management". Negahe Danesh publication. Iran. pp. 9-52, 68-72, 180-210, 295-307.
- Kamijo KI, Tanigawa T (1990). "Stock Price Pattern Recognition: A Recurrent Neural Network Approach". In: *Proceedings of the IEEE International Joint Conference on Neural Networks*. San Diego. pp. 215–221.
- Kimot T, Asakawa K, Yoda M, Takeoka M (1990). "Stock market prediction system with modular neural network." *Proceedings of the International Joint Conference on Neural Networks*. (pp. 1-6). San Diego, CA.
- Kosko Bart (1993). *Fuzzy Thinking: The New Science of Fuzzy Logic*". Hyperion press, New York. pp 148-247, 198-255.
- Lawrence R (1997). "Using Neural Networks to Forecast Stock Market Prices" *Department of Computer Science-University of Manitoba*.
- Neter John, Wasserman William, Whitmore GA (1992). "Applied Statistics", 4th ed. Allyn & Bacon publication Inc., September 1992, pp. 1102-1210.
- Nishina T, Hagiwara M (1997). "Fuzzy inference neural network", *Neuro-computing*, 14: 223 – 239.
- Rumelhart DE, Hinton GE, Williams RJ (1986). "Learning internal representations by error propagation" In D. E. Rumelhart and James L. McClelland, editors, "Parallel Distributed Processing: Explorations in the Microstructure of Cognition. 1 chapter 8, pages 318-362. The MIT Press.
- Stephen J. Brown, William N, Goetzmann, Alok Kumar (1998). "The Dow Theory: William Peter Hamilton's Track Record Reconsidered" *The J. Finance*. . LIII, No. 4. August 1998.
- White H (1993). Economic prediction using neural networks: The case of IBM daily stock returns". In *Neural Networks in Finance and Investing*, chapter 18, pages 315–328. Probus Publishing Company.
- Whitley D, Rana S, Dzuber J (1996). "Evaluating evolutionary algorithms." *Artificial Intelligence*. Aug 1996. 85(1-2): 245-276.
- Source of research Data, Web site of source data available at: www.irbourse.com , access date: 2008, August.