

*Full Length Research Paper*

# Quantitative analysis of optimal access charge of voice over internet protocol (VoIP)

Sung-Uk Park<sup>1</sup> and SoonHu Soh<sup>2\*</sup>

<sup>1</sup>Department of Policy Research, KISTI, Daejeon, South Korea.

<sup>2</sup>Division of Business Administration, Wonkwang University, Iksan, South Korea.

Accepted 31 March, 2011

Due to the expansion of service-based competition in the telecommunications market, the business on VoIP (voice over internet protocol) has emerged in service market. In this paper, the mathematical model to examine the welfare effect of access charge in the telecommunication market through the new VoIP providers entering the market was analyzed. The study also analyzes the simple model in two markets with independent demands. This paper examines the social optimal access charge and the viable industry Ramsey optimal access charge according to the entering of VoIP in telecommunication market. So, it compared two results in order to find some economic conclusions. Next by extending the basic model into the model with interdependent demands of VoIP companies; the study also calculate the social optimal access charge and viable industry Ramsey optimal access charge and compare the obtained results. Finally, it discusses some policy-relevant conclusions for the telecommunication industry.

**Key words:** VoIP, social optimal access charge, second-best access charge, independent demand, interdependent demand.

## INTRODUCTION

VoIP (voice over internet protocol) technology is a rapidly expanding field. More and more VoIP components are being developed, while existing VoIP technology is being deployed at a rapid pace. According to Ahuja and Ensor (2004), this growth is fueled by two goals: decreasing costs and increasing revenues. Network and service providers see VoIP technology as a means of reducing their cost of offering existing voice-based services and new multimedia services. Service providers also view

VoIP infrastructure as an economical base on which to build new revenue generating services. As deployment of VoIP technology becomes widespread and part of a shared competitive landscape, this second goal will become more important with service providers working to increase their market bases. Especially, Korea Communications Commission plans to add a separate VoIP service that is different from existing Public Switched Telephone Network (PSTN) services. It will be provided after being allocated to service areas and frequencies within the key communication infrastructure after categorizing VoIP as "an electronic communication service to be provided over the internet regardless of service areas by using electronic communication systems". The ministry also plans to designate VoIP as a key communication service by amending the Telecommunications Act after giving the number '0N0 (040 or 070)' for VoIP so that users can distinguish between VoIP and the PSTN. Once VoIP is included in the policy, the VoIP providers distinguishing local and long-distance calls (local number is expected to be used) and the VoIP providers (using 0N0) providing services regardless of service area will

\*Corresponding author. E-mail: [soonhu@wonkwang.ac.kr](mailto:soonhu@wonkwang.ac.kr). Tel: +82-63-850-6238.

**Abbreviations:** VoIP, Voice over internet protocol; PSTN, public switched telephone network; ISP, internet service providers; ITSPs, internet telephony service providers; ADSL, asymmetric digital subscriber line; HFC, hybrid fibre-coaxial; MVNO, mobile virtual network operator, VoBB, voice over broadband; LAN, local area network; PC, personal computer; IP, internet protocol; VFRO, viable firm Ramsey optimum; VIRO, viable industry Ramsey optimum; IAP, internet access providers

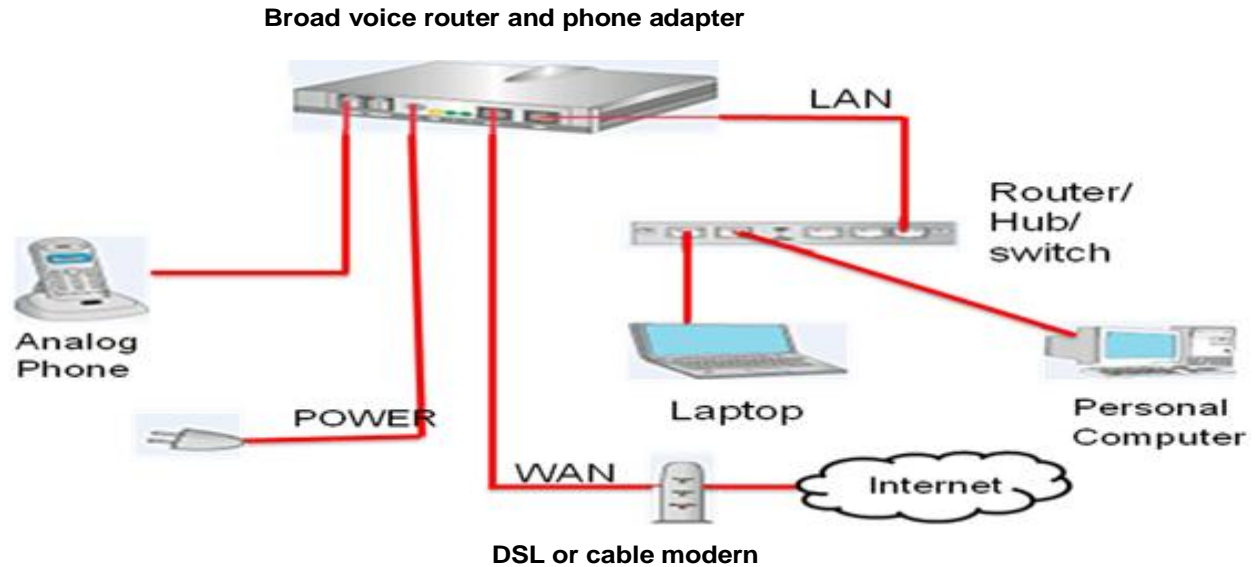

**Figure 1.** Example of VoIP adapter setup in residential network (Wikipedia, 2010).

will pay Internet service providers (ISP) in order to provide telephone services just like PSTN. Therefore, when major VoIP providers provide VoIP services to ISP, calculating optimal access charges will become a major issue.

As of 2010, there were over 90 VoIP providers in Korea, including the major telecommunications service providers KT, SK Broadband, LG, and Samsung Networks, as well as special ITSPs (Internet Telephony Service Providers) such as Anyuser Net, Serome Technology and KNSARAM Computer. LG, is one of the major VoIP providers, and is providing VoIP services for a base price of 2,000 won Asymmetric Digital Subscriber Line (ADSL), 1,000 won Hybrid fibre-coaxial (HFC), and 39 won for three minutes of every local and long-distance call. The VoIP costs of SK Broadband are similar to the local and LM calls provided by KT, while the base price is 62 to 80% cheaper and long-distance calls are 55, 78 and 85% cheaper for one, two and three minutes, respectively. When VoIP is included as part of the 'Internet telephony', the access charges will affect the prices of major VoIP providers. The most important factor in the government's decision regarding the access charge is that of improving the public welfare as much as possible without reducing the investments made by existing companies. Also, optimal access charges for VoIP must be determined by considering the interdependency between VoIP and PSTN. Therefore this study focuses on a comparative analysis of the demand for independent and interdependent data networks in order to figure out how to determine the access charges once VoIP has been officially recognized in the data network market by considering the above factors. Extending the discussions by Park (1998) and Kim and Park (2004, 2005), especially Kim and Park

(2004) examine the optimal access charge of MVNO (Mobile Virtual Network Operator) is different depending on demand function. So, we consider two different demand types of VoIPs, either case of independent demand or case of interdependent demand. The organization of this paper is as follows. First a brief overview of VoIP is given and then the basic model of analysis is presented. Finally, the results from economic model are discussed and the conclusion concerning the VoIP business and policy is provided.

## OVERVIEW OF VoIP

VoIP is a general term for a family of transmission technologies for delivery of voice communications over Internet Protocol (IP) networks such as the Internet or other packet-switched networks. Other terms frequently encountered and synonymous with VoIP are IP telephony, Internet telephony, voice over broadband (VoBB), broadband telephony and broadband phone by Wikipedia (2010). In Korea, VoIP is defined as those phone services provided over the Internet and not through other existing telephone networks, while a VoIP provider is defined as a telecommunication service provider that provides VoIP services by installing and using telecommunication systems. VoIP services include all types of voice communication over the Internet without specific calling or service areas, and the services can be provided through portable wired devices, wireless local area network (LAN), mobile Internet, and wireless Internet. In short, the main characteristic of VoIP is that it has all the features of wired/wireless voice and data communication by Kim and Park (2005). The existing interconnection

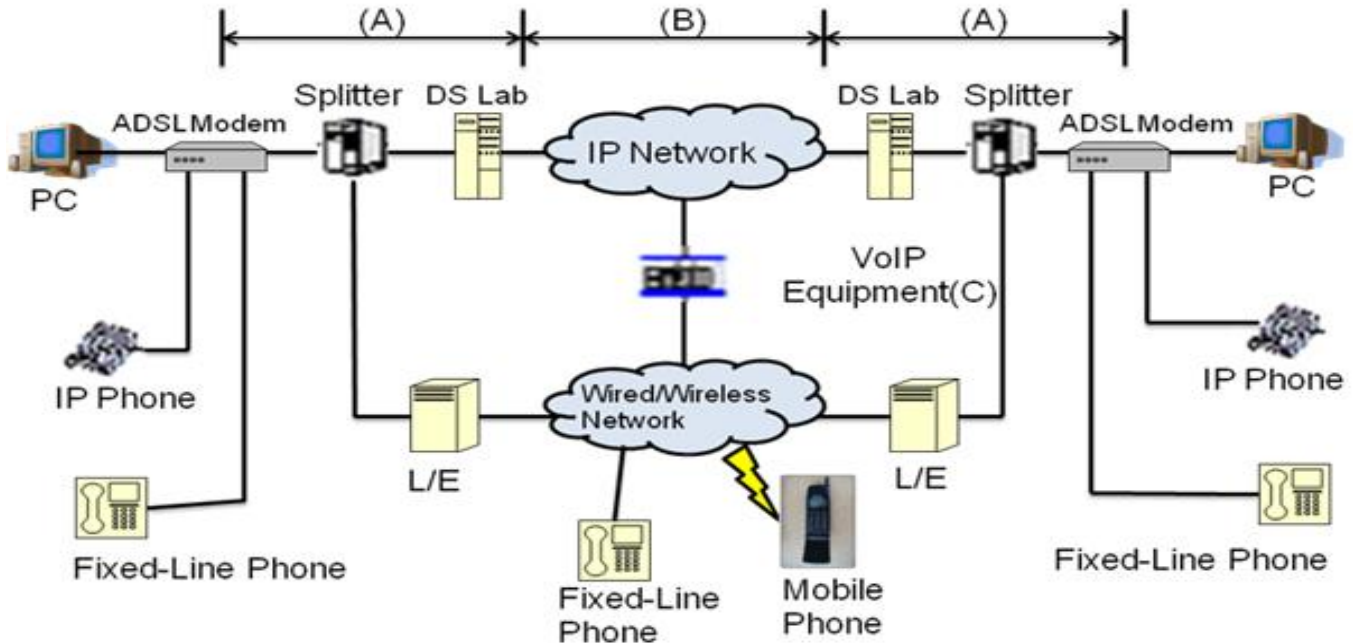

Figure 2. VoIP connection network.

system cannot be applied once the new VoIP service has been implemented. This is because VoIP is a form of voice communication from the point of view of service and a form of data in terms of network. But once the VoIP policy is established, the connection cost can be calculated for each component of the VoIP network. Figure 2 shows how a VoIP access charge (network cost) on the VoIP connection network can be charged (Kim and Park, 2005). Section (A) represents the high-speed internet access network, (B) represents the backbone internet networks (ISP network, IX network, etc.) and (C) the VoIP equipment (G/W, G/K, proxy server, etc.). The key VoIP providers issued with a common prefix number (0N0-ABYY-YYYY) will be paid for IP Phone-to- Personal computer (PC) but not for PC-to-PC calls, and pay the access charges (outgoing) to the internet access providers (IAP) and the ISP (Internet Service Provider). In the case of PC-to-IP Phone, VoIP providers charge users and pay the access charges (incoming) to the IAP and the ISP. In the case of IP Phone-to-IP Phone, VoIP providers charge users and pay access charges for both incoming and outgoing calls to the IAP and the ISP. This study only covers IP Phone-to-IP Phone calls.

#### SCENARIOS OF MODEL ANALYSIS

In relation to the principles of deriving access charge levels, there is a fundamental issue of allocation of charges between network owners and competing entities within the same market. However, the recent trend of fixed line and mobile convergence and introduction of integrated communication services has increased competition between different markets, which has made the allocation issue even more critical. Cave et al. (2002) dealt with the

economic characteristics of the sector, which define the industry's structure. Laffont and Tirole (1996) pointed out that in relation to determination of access charges, introduction of competition is the key factor for the telecommunications, electricity, gas and other industries. Larson and Lehman (1997) made a study that defined the essence of the materials used in production by monopolists (upstream) and the attributes of efficient access charge levels. Regarding the Ramsey Price Determination Policy, which is used here, the efficient ECPR was induced in special circumstances. Prieger (1996) stressed the importance of public welfare in relation to Ramsey Price Determination Policy, in the case a company, which is under regulatory control, but does not act as a monopolist would. De Bijl and Peitz (2009) analyzed the effect of access regulation and retail price regulation of PSTN networks on the adoption of a new technology in the form of VoIP. Park (1998) and Kim and Park (2004, 2005) applied and expanded the independent models and the interdependent models in telecommunication market. Optimal access charge levels will be studied based on the information provided above; using both the independent demand case and Interdependent demand case. The model used here assumes that an existing carrier exists as a monopoly in the upstream market and in the downstream market that existing and new company competes together in the VoIP market of local IP market. The basic model for the quantitative analysis is based on the Leite et al. (1997) and Park (1998) models. It is assumed to constant returns to scale. And not considered fixed cost of entrant.

#### Case of independent demand

In this case, the profits for existing companies and new entrants of VoIP providers are as follows. We applied and expanded a model of Park (1998) and Kim and Park (2004, 2005).

$$\begin{aligned}\Pi^I &= p_1 q_1^I + p_2 q_2^I + \alpha q_2^{VoIP} - c_1 (q_1^I + q_2^I + q_2^{VoIP}) - c_2 q_2^I \\ \Pi^{VoIP} &= (p_2 - \alpha - c_2) q_2^{VoIP}\end{aligned}$$

Taking a look at the profit for existing companies  $\Pi^I$ ,  $p_1q_1^I$  is income of the upstream market,  $p_2q_2^I$  is income of the downstream market,  $\alpha q_2^{VolP}$  is access charges received by new entrants,  $c_1(q_1^I + q_2^I + q_2^{VolP})$  is the cost incurred by the upstream market and  $c_2q_2^I$  is the cost incurred by the downstream market. In relation to  $\Pi^{VolP}$ , new entrant VoIP profits,  $p_2q_2^{VolP}$  is income of the downstream market,  $\alpha q_2^{VolP}$  is access charges disbursed to existing companies,  $c_2q_2^{VolP}$  is cost incurred by the downstream market. In this model, the upstream market is assumed to comprise of only existing companies in a monopolistic market while the downstream market is assumed to be a competitive market with multiple new entrants. Market equilibrium due to competition  $q_1^I, q_2^I, q_2^{VolP}$  is as follows.

$$\frac{\partial \Pi^I}{\partial q_1^I} = p_1 + p_1 q_1^I - c_1 = 0 \quad (1)$$

$$\frac{\partial \Pi^I}{\partial q_2^I} = p_2 + p_2^2 q_2^I - c_1 - c_2 = 0 \quad (2)$$

$$\frac{\partial \Pi^{VolP}}{\partial q_2^{VolP}} = p_2 + p_2^2 q_2^{VolP} - \alpha - c_2 = 0 \quad (3)$$

In order to ascertain the difference in change of the results relating to access charges, the implicit functions of (2 and 3) is used to make a partial differentiation in regards to access charges. By using Kramer's equation (Laffont and Tirole, 2000; Tirole, 1989), results are as follows.

$$\frac{dq_2^I}{d\alpha} > 0, \frac{dq_2^{VolP}}{d\alpha} < 0, \frac{dq_2}{d\alpha} < 0$$

If access charges were to rise, the quantity of existing companies would increase while the quantity of VoIP providers and the downstream market would both decrease. In case the maximization of social welfare is deemed to be optimum end-result, the maximization of the social welfare variable  $W$  is desired.

$$\begin{aligned} \text{Max } W &= V(q_1, q_2) + \Pi^I + \Pi^{VolP} \\ &= \int_0^{q_1} p_1(v)dv - p_1 q_1 + \int_0^{q_2} p_2(v)dv - p_2 q_2 + p_1 q_1^I + p_2 q_2^I - c_1(q_1^I + q_2^I) - c_2 q_2^I \end{aligned}$$

Henceforth, looking at  $W$  which is the factor that maximizes  $W$ , it is as follows:

$$\text{Subsequently, } p_2^F = c_1 + c_2 \quad (4)$$

Values derived from (1 and 4) is expressed as  $q_1^F, q_2^F$ . For (2 and 3) the equation for profit maximization is as follows.

$$2p_2 + p_2^2 q_2^* - \alpha - c_1 - 2c_2 = 0 \quad (5)$$

When social welfare maximization conditions (4 and 5) are matched then the equation is as follows.

$$2(p_2 - c_1 - c_2) = \alpha - p_2^2 q_2^* - c_1$$

$$\text{So, } \alpha^F = c_1 + \frac{c_1 + c_2}{\eta_2} < c_1 \quad (6)$$

As seen by (6), first best access charge is not equal to marginal cost pricing but in fact access charge is determined at a point below the marginal cost pricing level. An analysis can be made using VFRO (Viable Firm Ramsey Optimum), which assumes a company's profit is over 0 or VIRO (Viable Industry Ramsey Optimum), which assumes an industry's profit is over 0. As VFRO has more stringent conditions compared to VIRO, we will apply VIRO. If we express this in the form of a Lagrange formula, it is as follows.

$$\text{Max } L = W + \lambda(\Pi^I + \Pi^{VolP})$$

If express this in the form of a Lagrange formula, it is as follows.

$$\text{Max } L = W + \lambda(\Pi^I + \Pi^{VolP}) = V + (1 + \lambda)(\Pi^I + \Pi^{VolP})$$

The optimum of  $q_2$  value is as follows.

$$\frac{p_2^S - c_1 - c_2}{p_2^S} = -\frac{\lambda}{1 + \lambda} \frac{p_2^2 q_2}{p_2} = -\frac{\lambda}{1 + \lambda} \frac{1}{\eta_2} \quad (7)$$

So, it can be express as the solution derived by (1 and 7) as  $q_1^S, q_2^S$ . (7) is the second-best result value taking into account corporate profits. As seen by (5).

$$\alpha^S = \left(\frac{1 - \lambda}{1 + \lambda}\right) \frac{p_2}{\eta_2} + c_1 \quad (8)$$

$$\text{So, } \alpha^S = \left(\frac{1 - \lambda}{1 + \lambda}\right) \left(\frac{c_1 + c_2}{\eta_2 + \lambda}\right) + c_1 < c_1 \quad (9)$$

Access fee may have been determined below unit cost but survival is possible.

### Case of interdependent demand

In this case, the profits for existing companies and new entrants of VoIP providers are as follows. We applied and expanded a model of Kim and Park (2004, 2005) and Park (1998).

$$\Pi^I = p_1 q_1^I + p_2 q_2^I + \alpha q_2^{VolP} - c_1(q_1^I + q_2^I + q_2^{VolP}) - c_2 q_2^I$$

$$\Pi^{VolP} = (p_2 - \alpha - c_2) q_2^{VolP}$$

The follow-on conditions are as follows.

$$\frac{\partial \Pi^I}{\partial q_1^I} = p_1 + p_1^1 q_1^I + p_2^1 q_2^I - c_1 = 0 \quad (10)$$

$$\frac{\partial \Pi^I}{\partial q_2^I} = p_1^2 q_1^I + p_2 + p_2^2 q_2^I - c_1 - c_2 = 0 \quad (11)$$

$$\text{Max } W = V(p_1(q_1, q_2), p_2(q_1, q_2)) + (\Pi^I + \Pi^{VolP}) = V(p_1(q_1, q_2), p_2(q_1, q_2)) + p_1 q_1^I + p_2 q_2 - c_1(q_1^I + q_2) - c_2 q_2$$

Henceforth, looking at  $q_2$ , which is the factor that maximizes  $W$ , it is as follows.

$$\frac{\partial W}{\partial q_2} = p_2 - c_1 - c_2 = 0 \quad (13)$$

Consequently,  $\hat{p}_2 = c_1 + c_2$ .

The values derived from (10 and 13) is expressed as  $\hat{q}_1^F, \hat{q}_2^F$ . Same as the independent demand case, marginal cost pricing where consumer surplus and producer surplus is maximized is realized. To determine the first best access charge for the downstream market, the profit maximization conditions (11 and 12) are applied.

$$\text{Consequently, } \hat{\alpha}^F = c_1 + \frac{c_1 + c_2}{\eta_2} + \frac{\partial p_1}{\partial q_2} \hat{q}_1^F.$$

A comparison can be made between the independent demand case. Consequently,  $\hat{p}_1^2 \geq 0$ , and if the relationship is of substitution

$\hat{\alpha}^F \geq \alpha^F$  and  $\hat{p}_1^2 < 0$ , if the relationship is complementary  $\hat{\alpha}^F < \alpha^F < c_1$ . There is also a possibility that  $\hat{\alpha}^F < c_1$ , if the

relationship is of substitution and  $\hat{\alpha}^F > c_1$ , if it is complementary. If corporate profits are included in the analysis as was done in the independent demand model, the formula is as follows.

$$\text{Max } W = V(p_1(q_1, q_2), p_2(q_1, q_2)) + (\Pi^I + \Pi^{VolP}).$$

$$\text{The optimum } q_2 \text{ value is } \frac{\partial L}{\partial q_2} = 0 \quad (14)$$

The solution derived from 10) and 13) is expressed as  $\hat{q}_1^S, \hat{q}_2^S$ . Then 14) is applied.

$$\frac{p_2 - c_1 - c_2}{\hat{p}_2} = -\frac{\lambda}{1 + \lambda} \left( \frac{p_1^2 \hat{q}_1^S}{\hat{p}_2} + \frac{p_2^S \hat{q}_2^S}{\hat{p}_2} \right)$$

The afore result is the second-best result value taking into account

$$\frac{\partial \Pi^{VolP}}{\partial q_2^{VolP}} = p_2 + p_2^2 q_2^{VolP} - \alpha - c_2 = 0 \quad (12)$$

The solution derived above is expressed as,  $\hat{q}_1^*, \hat{q}_2^*$ . In case, the maximization of the social welfare variable  $W$  is desired.

corporate profits. If  $\lambda = 0$ , it becomes the first-best value, which means the condition is insignificant. Combining Equation (11 and 12) results in

$$\hat{\alpha}^S = c_1 + \frac{1 - \lambda}{1 + \lambda} \left( \frac{c_1 + c_2}{\eta_2} + p_1^2 \hat{q}_1^S \right).$$

Here,  $\hat{p}_1^2 \geq 0$ , hence if the relationship is of substitution basis

both  $\hat{\alpha}^S \geq c_1$  and  $\hat{\alpha}^S < c_1$  is possible.  $\hat{p}_1^2 < 0$ , and if it is

complementary  $\hat{\alpha}^S < c_1$ . In any case, if the relationship is of

substitution basis there is a possibility  $\hat{\alpha}^S > c_1$ . This applies only if

market  $q_1$  is relatively large than market  $q_2$ , which can be translated into a case where the quantity of the upstream market is larger than the aggregate quantity of the downstream market. However, if the size of the two markets is similar, even if  $q_1 \cong q_2$  has a complementary relationship if  $|p_1^2| < |p_2^2|$  then  $\hat{\alpha}^S < c_1$ .

## ANALYSIS RESULTS

The results from economic model are as follows;

In the case of independent demand, first the rise in access charges may increase the volume of existing companies but it decreases the volume of new entrant VoIPs and the whole downstream market (competitive market). Secondly, the first best price of the upstream market (monopolistic market) is equal to the marginal cost of the market while the first best price of the downstream market (competitive market) is equal to the marginal cost of the upstream market plus the marginal cost of the downstream market. Thirdly, the first best access charge based on the economic model is  $\hat{\alpha}^F = c_1 + \frac{c_1 + c_2}{\eta_2} < c_1$  and the economic significance of this

formula is that access fee level is determined at a point below the marginal cost of existing companies and is inversely proportional to  $\eta_2$ . In the case price elasticity of the downstream market increases, access charge declines while a decrease in price elasticity leads to arise

in access charge. Furthermore, access charge level cannot be determined through marginal cost pricing and in fact is determined at a point below marginal cost. Fourthly, when corporate profitability is accounted for the second best access fee level is deemed to be

$$\alpha^S = \left( \frac{1-\lambda}{1+\lambda} \right) \left( \frac{c_1+c_2}{\eta_2+\lambda} \right) + c_1 < c_1$$

and although it is below marginal cost, it is a level where operations are sustainable.

In case of Interdependent demand the results are as follows; First, same as the independent demand model the marginal cost pricing formula is  $\hat{p}_2 = c_1 + c_2$ . Secondly, the first best access charge level based on the economic model is  $\hat{\alpha}^F = c_1 + \frac{c_1+c_2}{\eta_2} + \frac{\partial p_1}{\partial q_2} q_1$  and comparing this to the independent demand model then  $p_1^2 \geq 0$  hence, if the relationship is of substitution basis  $\hat{\alpha}^F \geq \alpha^F$  and  $p_1^2 < 0$ , if the relationship is complementary  $\hat{\alpha}^F < \alpha^F < c_1$ . There is also a possibility that  $\hat{\alpha}^F < c_1$ , if the relationship is of substitution and  $\hat{\alpha}^F > c_1$ , if it is complementary.

In case the relationship is of substitution basis, the access charge for the interdependent model is higher than for the independent model and also can be higher than marginal cost of  $c_1$ .

However, if the relationship is complementary, the access charge is higher for the independent model, but lower than marginal cost.

Thirdly, if corporate profitability is considered the second best access charge level is  $\hat{\alpha}^S = c_1 + \frac{1-\lambda}{1+\lambda} \left( \frac{c_1+c_2}{\eta_2} + p_1^2 q_1 \right)$ .

Then  $p_1^2 \geq 0$ , hence, if the relationship is of substitution

basis then both  $\hat{\alpha}^S \geq c_1$  and  $\hat{\alpha}^S < c_1$  are possible. It is clear the second best access charge level is higher for the interdependent model than the independent model.

On the other hand  $p_1^2 < 0$ , which in turn means if the relationship is complementary  $\hat{\alpha}^S < c_1$ . Subsequently, the second best access charge level for the interdependent model and the independent model are lower than marginal cost.

## Conclusions

Rapid proliferation of the local and mobile telephony is evident globally. However, the IAP and the ISP are seeing continued consolidation with active mergers and

acquisitions between carriers and many countries are experiencing a decrease in carrier numbers. Market leaders are domineering the downstream competitors in terms of market share and hence the IP telephony market is transforming from a competitive market to an oligopoly. Countries are now proactively formulating policies and measures to boost competition within the IP phone market and companies are also devising ways of providing IP phone to services without a license by taking advantage of VoIP. Despite the benefits anticipated from the introduction of VoIP, the issue relating to access charges for existing carriers will emerge. In this research paper, a study was made on how access charge is to be determined following the introduction of VoIP by taking into consideration a case where demand is deemed to be independent and a case where demand is interdependent. In particular, for the interdependent model, access charge was different when accounting for whether a substitution or complementary relationship was existent in the market. Through a detailed analysis, we found that the optimal access charge for the interdependent model is higher than the independent model if demand for VoIP is of a substitution based relationship and also optimal access charge is higher than marginal cost. However, if the relationship is complementary, the access charge is lower than the marginal cost of the upstream market. Henceforth, in case of VoIP, if there are disputes with existing carriers in relation to network and bandwidth usage, whether the relationship is of substitution or complementary basis should be confirmed first and then reflected in the access charge determination policy.

## ACKNOWLEDGEMENT

The authors would like to thank the editor-in-chief, Professor Wilfred Isioma Ukpere and the anonymous reviewers for their thoughtful suggestions which helped to improve the quality of the paper. This paper was supported by Wonkwang University in 2011.

## REFERENCES

- Ahuja SR, Ensor R (2004). VoIP: What is it Good for? *Mag. Queue*, 2(6): 48-55.
- De Bijl P, Peitz M (2009). Access regulation and the adoption of VoIP. *J. Regul. Econ.*, 35(2): 111-134.
- Cave ME, Vogelsang I, Majumdar SK (2002). *Handbook of Telecommunications Economics, Structure, Regulation, and Competition*. North-Holland, Vol. 1.
- Kim BW, Park SU (2004). Determination of the Optimal Access Charge for the Mobile Virtual Network Operator System. *ETRI J.*, 26(6): 665-668.
- Kim BW, Park SU (2005). A Study on a Model for Determining Optimal VoIP Access Charge. Portland International Center for Management of Engineering and Technology, HB-10.1.
- Laffont JJ, Tirole J (1996). Creating Competition through Interconnection: Theory and Practice. *J. Regul. Econ.*, 10(3): 227-256.
- Laffont JJ, Tirole J (2000). *Competition in Telecommunications*. The MIT Press.
- Larson AC, Lehman DE (1997). Essentiality, Efficiency, and the Efficient

- Component-Pricing Rule. *J. Regul. Econ.*, 12(1): 71-80.
- Leite AN, Santos V, Seabra MC (1997). Instrument Insufficiency in Access-Pricing Regulation of Telecommunications. *Global Networking Joint Conference*, pp. 292-299.
- Park SU (1998). The Introduction of Competition in the Network Industries, and the Welfare of Access Charge. Master's thesis. Chonnam National University. South Korea.
- Prieger JE (1996). Ramsey Pricing and Competition: The Consequences of Myopic Regulation. *J. Regul. Econ.*, 10(3): 307-321.
- Tirole J (1989). *Theory of Industrial organization*. The MIT Press.
- Wikipedia (2010). Voice over Internet Protocol. [http://en.wikipedia.org/wiki/Voice\\_over\\_Internet\\_Protocol](http://en.wikipedia.org/wiki/Voice_over_Internet_Protocol).