

Full Length Research Paper

The Hsp40-Hsp70 chaperone machinery of *Plasmodium falciparum*

Eva-Rachele Pesce* and Gregory L. Blatch

Biomedical Biotechnology Research Unit, Department of Biochemistry, Microbiology and Biotechnology, Rhodes University, Grahamstown 6140, South Africa.

Accepted 4 December, 2008

***Plasmodium falciparum* is the protozoan parasite responsible for the most virulent form of malaria. The majority of the asexual stages of its life cycle occur in the human erythrocyte. Since the infected erythrocytes undergo dramatic structural and functional changes upon parasite infection, malaria research has been focusing on investigating the proteins potentially involved in host cell modifications. Molecular chaperones are believed to play an important role in erythrocyte remodelling as many of these proteins are predicted to be exported into the erythrocyte cytoplasm. A family of molecular chaperones that has recently received much attention is the heat shock protein family (Hsps), and in particular members belonging to the 40 and 70 kDa heat shock proteins classes (Hsp40s and Hsp70s). This review summarises the latest *in silico* and *in vivo* data available on *P. falciparum* Hsp40s and Hsp70s.**

Key words: *Plasmodium falciparum*, malaria, Hsp40s, Hsp70.

INTRODUCTION

Malaria is a worldwide disease, which affects more than 500 million people annually (World Health Organization, 2007). There are four species of *Plasmodium* parasites that infect humans: *Plasmodium malariae*, *Plasmodium ovale*, *Plasmodium vivax* and *Plasmodium falciparum*. The most virulent and dangerous form of malaria is caused by *P. falciparum*. The life cycle of *P. falciparum* occurs in two host organisms: anopheline mosquito and human. During its life inside the human host, the parasite invades firstly the hepatocytes and subsequently the erythrocytes. The etiology of the disease is closely associated with the asexual stages of *Plasmodium*; in fact the burst of infected erythrocytes accounts for the fever episodes typical of malaria. The parasite resides in the host erythrocyte within the parasitophorous vacuole (PV). Since the mature erythrocyte lacks most of the organelles, protein synthesis and trafficking machinery, *P. falciparum* needs to modify the host cell in order to be able to develop and survive. Structural and functional remodelling of the erythrocyte includes the establishment in the erythrocyte cytoplasm of new membranous called knobs at the surface of

the host cell (Kilejian, 1979). The Maurer's clefts are considered to function as a specialised parasite compartment for the trafficking of parasite proteins to the erythrocyte plasma membrane. Among such proteins are knob-associated histidine-rich protein (KAHRP) and *P. falciparum* erythrocyte membrane protein 1 (PfEMP1) which are destined to the knobs (Kilejian et al., 1977; Baruch et al., 1995; Smith et al., 1995; Su et al., 1995). The knobs have been associated with the ability of parasitised erythrocytes to adhere to the endothelial cells. The adhesion is mediated by PfEMP1 which binds host receptors like chondroitin sulphate A (CSA) and CD36 (Rogerson et al., 1995; Baruch et al., 1997). Cytoadherence of infected erythrocytes to the endothelium allows the parasite to prevent clearance by the spleen, and can cause severe cerebral malaria when the infected erythrocytes circulate in the brain capillaries (Aikawa, 1988; Craig and Scherf, 2001). To be able to modify the erythrocyte, *P. falciparum* exports several proteins across its plasma membrane and the PV to the erythrocytes cytoplasm and erythrocyte plasma membrane. Recently, two independent studies have identified a pentameric motif (RxLxE/Q/D) referred to as *Plasmodium* export element (PEXEL) or host targeting (HT) signal which is proposed to mediate the transport of parasite proteins to the host erythrocyte. This has led to the identification through bioinformatics analysis of a so-called malaria ex-

*Corresponding author: E-mail: e.pesce@ru.ac.za. Tel: +27-46-603-8672. Fax: +27-46-622-3984.

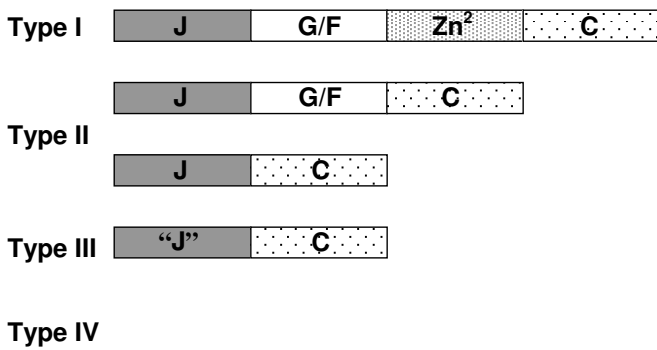

Figure 1. Schematic representation of *P. falciparum* Hsp40 proteins classified according to their domain organisation. **J**, J domain containing the highly conserved HPD motif; **G/F**, Gly/Phe-rich region; **Zn²⁺**, cysteine-rich zinc-binding domain; **C**, C terminus domain; **“J”**, J domain which does not contain the highly conserved HPD motif.

portome (Hiller et al., 2004; Marti et al., 2004). However, it has to be kept in mind that several exported proteins do not contain a PEXEL/HT motif. The exportome is predicted to consist of 300 - 400 proteins including the variant PfEMP1, kinases, phosphatases, putative transporters and heat shock proteins (Kooij et al., 2006; Sargeant et al., 2006). Heat shock proteins (Hsps) are highly conserved proteins, many of which function as molecular chaperones. Molecular chaperones are implicated in protein folding, prevention of protein aggregation and misfolding, protein transport, and assembly of multi-protein complexes (Ellis, 1987; Fink, 1999; Feldman and Frydman, 2000). The level of expression of Hsps is typically enhanced by stress conditions such as an increase of temperature but in general many Hsps are constitutively expressed. There is evidence that Hsp70 and Hsp90 chaperones play an important role in parasite survival during the stressful conditions of the intra-erythrocytic stages of *Plasmodium*, especially during the febrile episodes associated with malaria. PfHsp70-1 (*P. falciparum* Hsp70-1) expression is increased upon heat stress, and it has been found to be expressed at high levels during all intra-erythrocytic stages of the malaria life cycle. PfHsp90 (*P. falciparum* Hsp90) is believed to be crucial for cytoprotection and growth of the parasite (Biswas and Sharma, 1994; Joshi et al., 2002; Banumathy et al., 2003; Pavithra et al., 2004). In addition to being a significant component of the parasite exportome, molecular chaperones were identified as one of the major class of proteins residing in the PV (Nyalwidhe and Lingelbach, 2006). The presence of several molecular chaperones in the PV implies a potential pivotal role played by this class of proteins in the translocation of protein across the PV membrane to the host cell cytoplasm. Furthermore, proteomics analysis has revealed the possible presence of some chaperones in the Maurer's clefts suggesting that those chaperones may be part of the trafficking machinery used by the parasite to ensure the transport of the

exportome proteins to the erythrocyte plasma membrane (Vincensini et al., 2005). It is interesting to note that host chaperones may also be involved in trafficking of parasite proteins (Banumathy et al., 2002). It emerges, therefore, that parasite Hsps may possess a dual function: within the parasite they would ensure cytoprotection of the parasite and within the erythrocyte cytoplasm they would aid in the remodelling of the host cell. *P. falciparum* appears to possess a large number of Hsps belonging to the Hsp40 class (Hsp40s). Moreover several of the Hsp40s are predicted to be exported. This review focuses on the Hsp40 chaperone machinery of *P. falciparum* as well as on the Hsp70s which are natural partners of Hsp40s.

P. falciparum HSP40 proteins

Hsp40s generally functions as co-chaperones of Hsp70s. They deliver the substrate protein to Hsp70 and modulate the Hsp70 activity by interacting with its substrate-binding and ATPase domains (Cheetham et al., 1994; Kelley, 1998; Suh et al., 1998; Young et al., 2003). Typically, Hsp40s contain the highly conserved J domain which is fundamental for successful interactions between Hsp40s and Hsp70s. The J domain is approximately 70 amino acids long and composed of four α -helices (I-IV). It is characterised by the presence of the highly conserved HPD (His-Pro-Asp) motif which enables Hsp40s to stimulate the ATPase activity of Hsp70s (Tsai and Douglas, 1996). In addition to the N-terminal J domain, a canonical Hsp40 possesses a Gly/Phe-rich region (GF domain), a cysteine-rich zinc-binding domain and a C-terminal substrate-binding domain (Cheetham and Caplan, 1998). According to their domain organisation, Hsp40s are usually classified into three types: type I Hsp40s contain all four domains described above; type II Hsp40s lack the cysteine-rich zinc binding domain; and the type III Hsp40s contain only the J domain which in this type is not necessarily located at the N-terminus. Bioinformatics analysis has revealed that the *P. falciparum* genome encodes at least 43 Hsp40s. Interestingly, the parasite Hsp40 machinery exhibit a further Hsp40 type referred to as type IV. Type IV Hsp40s contain a J domain like other Hsp40s, but the HPD motif is not conserved (Botha et al., 2007) (Figure 1). The presence of this unique class of proteins in *P. falciparum* and other apicomplexa could reflect a more complex strategy used by parasites to regulate parasite and perhaps host Hsp70s.

Type I Hsp40s

In addition to bioinformatics analysis, recent microarray and high-throughput mass-spectrometry studies have given some insight into *P. falciparum* transcriptome and proteome of the different parasite life stages (Florens et al., 2002; Bozdech et al., 2003; Le Roch et al., 2003; Florens et al., 2004). Of the 43 Hsp40s encoded on the *P. falciparum* genome, only two belong to the type I class: PF14_

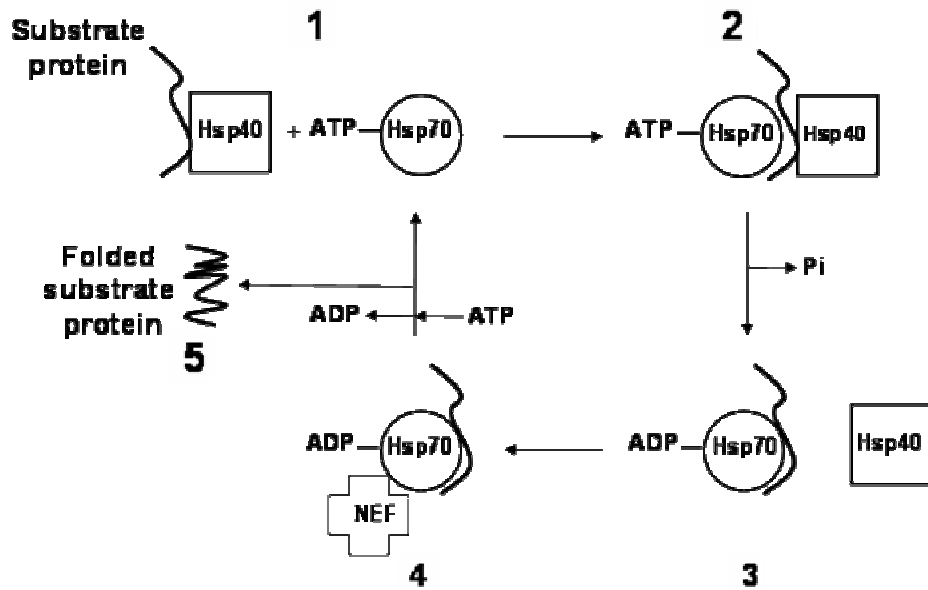

Figure 2. Schematic representation of the Hsp70 “catch and release” cycle: 1, Hsp40 binds a misfolded or unfolded substrate protein; 2, Hsp40 targets the substrate protein to ATP-bound Hsp70 and stimulates the ATP hydrolysis activity of Hsp70; 3, in its ADP-bound state Hsp70 binds to the substrate protein with high affinity; 4, nucleotide exchange factor (NEF) binds to the Hsp70-substrate protein complex mediating the nucleotide ex-change; 5, the replacement of ADP with ATP causes a conformational change that allows the release of the substrate protein from the Hsp70-substrate protein complex. The substrate protein may enter the cycle several times until it reaches proper folded state.

0359 and PFD0462w (Pfj1) (Table 1). Both proteins do not contain a signal sequence for predicted export to the erythrocyte cytoplasm and therefore they are believed to be parasite-resident (Botha et al., 2007). As they represent a more typical Hsp40, PF14_0359 and Pfj1 could be involved in basic chaperone processes and cytoprotection of the parasite. Although PF14_0359 is not predicted to be secreted into the host cell, proteomics data suggest its presence in the membrane of infected erythrocytes (Florens et al., 2002, 2004) (Table 1). As for many putative exported proteins, experimental validation of this localisation is required. A useful tool to try to unravel the possible functions of many *P. falciparum* proteins comes from a large scale analysis of protein interactions using high throughput yeast two-hybrid assays (LaCount et al., 2005; Suthram et al., 2005). According to these studies, PF14_0359 may interact with MSP7 (merozoite surface protein 7 precursor) (Pachebat et al., 2001) and a type II Hsp40, PFB0595w. Notably, both Hsp40s are expressed in the merozoite stage, therefore they could be involved in the correct folding and positioning of MSP7. There is no protein-protein interaction data and limited functional information on Pfj1. However, analysis of the mRNA of Pfj1 showed that the levels of transcript increased upon heat shock (Watanabe, 1997), suggesting that Pfj1 may be essential under heat stress conditions.

Type II Hsp40s

Until now, nine type II Hsp40s have been identified. Three of these proteins, PFE0055c, PF11_0099 and PFA0660w (Table 1), are considered part of the exportome (Sargeant et al., 2006). Apart from gene expression and mass-spectrometry information (Florens et al., 2002; Bozdech et al., 2003; Le Roch et al., 2003; Florens et al., 2004), very limited experimental data is available for the type II Hsp40s. Proteomics analysis of the Maurer's clefts and localisation studies have provided evidence for the presence of PFE0055c in the erythrocyte cytoplasm and the clefts (Vincensini et al., 2005; Bhattacharjee et al., 2008). The identification of substrate proteins and Hsp70 chaperone partners may help to define PFE0055c functions. It is possible that this parasite Hsp40 may interact with host chaperones, namely human Hsp70s, to fulfil its tasks. PF11_0099, also called Pfj2 (Watanabe, 1997), contains a proposed PEXEL/HT sequence that overlaps with the helix II of its J domain. It has been proposed that the export sequence of Pfj2 does not constitute a true export signal although this hypothesis has to be verified experimentally (Botha et al., 2007). In addition, Pfj2 is constitutively transcribed but the level of transcript decreases upon heat shock (Watanabe, 1997). Protein networks based on yeast two-hybrid analyses suggested a poten-

Table 1. *Plasmodium falciparum* Hsp40 chaperone machinery.

Type	Locus	Chromosome	PEXEL/HT ^a	kDa	TMD	Protein	Gene Expression ^b	Mass-Spec data ^c	Knock out ^d
I	PF14_0359	14		48.5		Hsp40 protein, putative	all stages	S, G, iRBCm, M, T	n.d.
	PFD0462w	4		75.9		Pfj1	none	T	n.d.
II	MAL13P1.277	13		24.3	1	Hsp40 protein, putative	bct	none	n.d.
	PFA0660w	1	•	47	1	Hsp40 protein, dnj/sis1 family	R, T, S, M	T	no
	PFB0090c	2		48.3		Hsp40 protein, putative	all stages	T	yes
	PFB0595w	2		37.4		Hsp40 protein, putative	all stages	G, M, T	n.d.
	PFE0055c	5	•	46.4	1	Hsp40 protein, putative	M	S, G, iRBCm, T	yes
	PFF1415c	6		44.7	1	Hsp40 protein, putative	none	S, G, iRBCm, M, T	n.d.
	PFL0565w	12		28		Pfj4	all stages	S, G, iRBCm, T	n.d.
	PF11_0099	11	•	62.4	1	Pfj2	all stages	S, G, iRBCm, T	n.d.
	PF14_0137	14		45.2	5	Hsp40 protein, putative	all stages	none	n.d.
	III	PFB0920w	2		117.3	2	Hsp40 protein, putative	R, T, S, M	Sp
PF10_0378		10	•	107.6	1	Pfj3	all stages	none	yes
PF11_0513		11		83.1		Hsp40 protein, putative	all stages	none	yes
PFL0055c		12	•	107.6	1	Hsp40 protein, putative	R, T, S	none	n.d.
PF07_0103		7		13		mitochondrial import inner membrane translocase subunit tim14, putative	all stages	none	n.d.
PF08_0032		8		76.7	3	Hsp40 protein, putative	R, T, S	G, M	n.d.
PF08_0115		8		76.8		Hsp40 protein, putative	all stages	iRBCm, Sp	n.d.
PF10_0032		10		170.9	1	Hsp40 protein, putative	R, T, S, G	Sp	n.d.
PF10_0058		10		94		Hsp40 protein, putative	all stages	none	n.d.
PF11_0273		11		76.4		Hsp40 protein, putative	R, T, S, Sp	none	n.d.
PF11_0380		11		44.5	1	Hsp40 protein, putative	R, T, S	none	n.d.
PF13_0036		13		38.9		Hsp40 protein, putative	R, T, S, G, Sp	none	n.d.
PF13_0102		13		75.9	3	Hsp40, Sec63 homologue	all stages	Sp	n.d.
PF14_0700		14		52.5		Hsp40 protein, putative	all stages	T, S, G, M, iRBC	n.d.
PFE0135w		5		16.4		Hsp40 protein, putative	G	none	n.d.
PFE1170w		5		61.9	2	Hsp40 protein, putative	T, S, M, G	M	n.d.
PFF1290c		6		17		Hsp40 protein, putative	none	none	n.d.
PFI0935w	9		43.3	6	Hsp40 protein, putative	all stages	G, T	n.d.	
PFI0985c	9		30	1	Hsp40 protein, putative	R, G,	Sp	n.d.	
PFL0815w	12		111.1		Hsp40 protein, putative	all stages	G, T	n.d.	
IV	PF10_0381	10	•	46.6	1	Hsp40 protein, putative	Sp, T, S	Sp	yes
	PF11_0034	11	•	67.3	1	Hsp40 protein, putative	bct	G, Sp	no

Table 1. Contd.

PFB0925w	2		71.8	1	Hsp40 protein, putative	bct	none	yes
PFB0085c	2	•	105.9	1	Hsp40 protein, putative	R, M	Sp	yes
PF11_0509	11	•	126.9		RESA, putative	R, S, M	S, T, M, iRBC	no.
PFA0110w	1		126.5		RESA	R, T, S, M	S, G, T, M, iRBC	yes
PF11_0512	11	•	95.5	1	RESA-2	bct	T	yes
PFA0675w	1	•	171	1	RESA-like protein	bct	G, S	n.d.
PF14_0013	14	•	59.2		Hsp40 protein, putative	R, M	M	n.d.
PFL2550w	12	•	56.6	1	Hsp40 protein, putative	all stages	none	.yes
PFE0040c	5	•	168.3		PfEMP2	T, S	S, T, iRBCm	n.d.
PF11_0443	11		39.4	2	Hsp40 protein, putative	all stages	G	n.d.

R ring stage; G gametocyte; Sp sporozoites; T trophozoite; S schizont; M merozoite; iRBC infected erythrocyte; iRBCm infected erythrocyte membrane; bct below confidence threshold; n.d. not determined

^a Hiller et al 2004; Marti et al 2004; Sargeant et al 2006

^b Bozdech et al 2003; Le Roch et al 2003

^c Florens et al 2002, 2004

^d Maier et al 2008

potential interaction between Pfj2 and a putative nucleosome assembly protein 1 thus proposing an important role for Pfj2 inside the parasite (LaCount et al., 2005). The third PEXEL/HT bearing protein PFA0660w has been recently included in a study aimed to identify proteins involved in virulence and rigidity of infected erythrocytes (Maier et al., 2008). In this study, the authors followed a loss-of function approach. Remarkably, it was not possible to obtain PFA0660w knock out parasites indicating that PFA0660w may be essential for survival of the parasite in infected erythrocytes. A fourth type II Hsp40, PFL0565w (Pfj4) (Watanabe, 1997), which does not contain a PEXEL/HT sequence has recently been investigated (Pesce et al., 2008). Pfj4 was found to localise to the cytoplasm and nucleus of trophozoite and schizont stages. In addition to its intra-parasitic location, Pfj4 was detected under certain conditions in the infected erythrocyte cytoplasm. The presence of Pfj4 in the infected erythrocyte cytoplasm is consistent with the proteomics data which identified Pfj4 in the infected erythrocyte membrane fraction (Table 1) (Florens et al., 2002, 2004). The protein levels were shown to increase upon heat shock, and immunoprecipitation and size exclusion chromatography data pointed to a possible interaction of Pfj4 with PfHsp70-1. Furthermore, yeast two-hybrid analyses (LaCount et al., 2005) suggested that Pfj4 interacted with PfGCN20 (*P. falciparum* gonial cell neoplasm protein 20), a parasite homologue of yeast Gcn20 which is involved in regulation of translation, and is a member of the ATP-binding cassette (ABC) protein family (Vazquez de Aldana et al., 1995).

Type III Hsp40s

In *P. falciparum* the type III Hsp40s class contains the highest number of proteins compared to the other three

classes (Table 1). They are also more divergent and they therefore may fulfil more specialised functions. According to the PlasmoDB website (www.plasmodb.org), the number of type III Hsp40s predicted to contain a PEXEL/HT sequence, and thus to be exported has changed from four (Sargeant et al., 2006) to two as a consequence of the ongoing reannotation effort. The PF11_0513 and PFB0920w protein sequences are no longer predicted to contain a PEXEL/HT motif. Maier et al. (2008) investigated the effect of the disruption of the PFB090w gene on infected erythrocytes. Although no variations were discovered in erythrocyte adhesion, knobs formation and localisation of PfEMP1 at the surface of the host cell, the authors were able to determine a change in erythrocyte rigidity (Maier et al., 2008).

Type IV Hsp40s

Twelve type IV Hsp40s are encoded by the *P. falciparum* genome and nine are predicted to be exported as they contain a PEXEL/HT sequence (Table 1) (Botha et al., 2007). Included in this class of Hsp40s are members of the RESA family which are known to be exported to the infected erythrocyte and localise under the erythrocyte plasma membrane. There, they interact with cytoskeletal proteins possibly mediating erythrocyte remodelling. Two putative exported proteins, PF11_0034 and PF11_0509, are proposed to be potentially essential for parasite survival in the host erythrocyte as the disruption of their genes was not achieved (Maier et al., 2008). In the same study, Maier et al. (2008) demonstrated that the knockout of another type IV, PF10_0381, had a significant impact on host cell remodelling; in fact, in the absence of PF10_0381, infected erythrocytes lost their adhesion to CS2 and they lacked knobs on their surface (Maier et al., 2008). Therefore, a number of the type IV Hsp40s are im-

Table 2. *Plasmodium falciparum* Hsp70 chaperone machinery

Locus	Chromosome	kDa	Protein	Gene expression ^a	Mass-spec data ^b
PF07_0033	7	100	PfHsp70-z, Cg4	all stages	T, S, G, iRBCm, M, Sp
PF08_0054	8	73.9	PfHsp70-1	all stages	T, S, G, iRBCm, M, Sp
PF11_0351	11	73.3	PfHsp70-3	all stages	T, S, G, iRBCm, M, Sp
PF10875w	9	72.4	PfHsp70-2, PfBiP, PfGrp78	all stages	none
MAL7P1.228	7	73.2	PfHsp70-x	none	none
MAL13P1.540	13	108.2	PfHsp70-y	none	none

T trophozoite; S schizont; G gametocyte; iRBCm infected erythrocyte membrane; M merozoite; Sp sporozoites

^a Bozdech et al 2003; Le Roch et al 2003

^b Florens et al 2002, 2004

portant for parasite survival, and since these Hsp40s are unique to *P. falciparum* they are ideal candidates as drug targets.

***P. falciparum* Hsp70s AND PfHsp40-PfHsp70 partnerships**

The expression of certain Hsp70s increases upon heat stress and many are also constitutively expressed. Hsp70s are characterised by the presence of an N-terminal ATPase domain (~45 kDa) and a peptide binding domain (~25 kDa) (Flaherty et al., 1990; Wang et al., 1993). Hsp70s typically bind to substrate proteins to allow their folding-refolding via an ATP dependent “catch and release” cycle (Figure 2). Hsp70s catch the substrate protein with high affinity when bound to ADP. When ADP is replaced by ATP, Hsp70s release the substrate protein as a consequence of a conformational change induced by the ATP binding (Szabo et al., 1994). The exchange of nucleotides, which is necessary for the cycle, is mediated by nucleotide exchange factors (NEFs). As co-chaperones, Hsp40s stimulates the ATP hydrolysis activity of Hsp70s enhancing, therefore, the transition of Hsp70s from ATP- to ADP-bound state (Suh et al., 1999). Hsp40s (reviewed in Hennessy et al., 2005) are also proposed to play an important role delivering substrate proteins to Hsp70s (Figure 2). Different Hsp40s, in fact, contain different peptide-binding domains (PPDs), which allow the target of specific substrate proteins to the Hsp70 chaperones (Cyr et al., 1994). The PPDs are believed to be situated in the central and C-terminal regions of type I and type II Hsp40s although the mechanism of binding has not been completely elucidated yet (Lu and Cyr, 1998; Fan et al., 2003). Both Hsp40s and Hsp70s are able to bind the substrate protein but the recognised regions differ. The presence of separated binding sites permits the formation of ternary complexes between the target protein and the two chaperones. Such complexes are proposed to ease the passage of the substrate protein from the Hsp40 to the Hsp70. (Han and Christen, 2003). Generally, the number of Hsp40s in an organism greatly exceeds the number of Hsp70s suggesting that the Hsp40

chaperone complement may provide additional substrate specificity to the Hsp70 counterpart. *P. falciparum* is no exception to this and its genome encodes at least six Hsp70s (Table 2) (Shonhai et al., 2007). Amongst the six proteins, PfHsp70-1 (PF08_0054) has been studied in the greatest detail, and shown to have most of the properties of a typical Hsp70 chaperone, but also some unique biochemical features (Matambo et al., 2004; Shonhai et al., 2005). Comparative protein modelling has been used to produce a predicted structure for PfHsp70-1 which in addition to the ATPase and peptide binding domains exhibits a functional linker region (Shonhai et al., 2005, 2008). PfHsp70-1 contains a C-terminal EEVD motif which is present in cytosolic Hsp70s including human Hsc70. The EEVD motif has been proposed to be implicated in the regulation of the interactions between Hsp70 and Hsp40 (Freeman et al., 1995). PfHsp70-1 is expressed in all the blood stages of the parasite, and its protein levels increase upon heat shock (Joshi et al., 1992; Biswas and Sharma, 1994; Pesce et al., 2008). PfHsp70-1 has been shown to localise to the parasite cytoplasm and nucleus (Kumar et al., 1991; Pesce et al., 2008). Although proteomics studies place PfHsp70-1 in the Maurer's clefts and PV (Vincensini et al., 2005; Nyalwidhe and Lingelbach, 2006), its presence in these compartments has not been confirmed yet with immunolocalisation experiments (Kumar et al., 1991; Pesce et al., 2008). Recently, it has been proposed that PfHsp70-1 may interact with the type II Hsp40, Pfj4 (Pesce et al., 2008). Yeast two-hybrid data (LaCount et al., 2005) suggested an interaction of PfHsp70-1 with PFE1405c, a putative eukaryotic translation initiation factor, and of Pfj4 with PfGCN20 a protein implicated in regulation of translation. Hence, it could be hypothesised that the two chaperones function together during protein translation. The detection of PfHsp70-1 in the PV and Maurer's clefts would suggest an association of PfHsp70-1 with protein export and trafficking in the erythrocyte cytoplasm. A possible Hsp40 partner, in this case, could be PFE0055c as this chaperone has been also identified in PV and Maurer's clefts by proteomics studies (Vincensini et al., 2005; Nyalwidhe and Lingelbach, 2006). Furthermore, PfHsp70-1 being a

Table3. Cellular Localisation of the *Plasmodium falciparum* Hsp40 chaperone machinery

Type	Locus	Parasite- Resident Hsp40s localisation		TYPE	Locus	Putative exported Hsp40s localisation	
		predicted	experimental			predicted	experimental
I	PF14_0359	cytoplasm ¹	iRBCm ²	II	PFA0066ow	mitochondrion ¹	
	PFD0462w	nucleus ¹ , apicoplast ³			PFE0055c	nucleus ¹ , apicoplast ³	iRBC cytoplasm ⁶ , MC ⁷
II	PFB0090c	nucleus ¹		III	PF11_0099	Golgi ¹	iRBC ²
	MAL13P1.277	cytoplasm ¹ , mitochondrion ⁴			PF10_0378	plasma membrane ¹	
III	PFB0595w	nucleus ¹		IV	PFL0055c	nucleus ¹	
	PFF1415c	extracellular ¹ , apicoplast ³			PF10_0381	nucleus ¹ , mitochondrion ⁴	
	PFL0565w	nucleus ¹	nucleus/cytoplasm ⁵ , iRBCm ²	PF11_0034	ER ¹ , mitochondrion ⁴		
	PF14_0137	plasma membr. ¹ , apicoplast ³		PFB0085c	Golgi ¹ , mitochondrion ⁴		
	PFB0920w	nucleus ¹ , mitochondrion ⁴		PF11_0509	nucleus ¹ , mitochondrion ⁴	iRBC ²	
	PF11_0513	nucleus/cytoplasm ¹		PFA0110w	mitochondrion ⁴	iRBC ^{2,8}	
	PF07_0103	cytoplasm ¹ , apicoplast ³		PF11_0512	nucleus ¹ , mitochondrion ⁴		
	PF08_0032	plasma membrane ¹		PFA0675w	nucleus ¹		
	PF08_0115	nucleus ¹	iRBCm ²	PF14_0013	nucleus ¹		
	PF10_0032	nucleus ¹		PFL2550w	nucleus ¹		
PF10_0058	nucleus ¹ , mitochondrion ⁴		PFE0040c	nucleus ¹	iRBCm ²		
PF11_0273	nucleus ¹		iRBC infected erythrocyte; iRBCm infected erythrocyte membrane;				
PF11_0380	nucleus/ER ¹		ER endoplasmic reticulum; MC Maurer's Clefts				
PF13_0036	ER ¹		¹ Nakai and Horton 1999				
PF13_0102	ER ¹		² Florens et al 2002, 2004				
PF14_0700	nucleus ¹	iRBC ²	³ Zuegge et al 2001				
PFE0135w	nucleus ¹		⁴ Bender et al 2003				
PFE1170w	ER ¹		⁵ Pesce et al 2008				
PFF1290c	apicoplast ³ , mitochondrion ⁴		⁶ Bhattacharjee et al 2008				
PFI0935w	ER ¹		⁷ Vincensini et al 2005				
PFI0985c	ER ¹ , mitochondrion ⁴		⁸ Brown et al 1985				
PFL0815w	nucleus ¹						
IV	PFB0925w	plasma membr. ¹ , apicoplast ³					
	PF11_0443	cytoplasm ¹ , apicoplast ³					

typical Hsp70s may interact with the two typical type I Hsp40s Pfj1 and PF14_0359 in the parasite cytoplasm. An Hsp70 that might possess overlapping functions with PfHsp70-1 is PfHsp70-x (MAL7P1.228) (Table 2). This protein has not been characterised yet but it contains a C-terminal EEVN motif and shares 73% identity with PfHsp70-1 (Shonhai et al., 2007). PfHsp70-2 (PFI0875w)

(Table 2), also referred to as PfBiP and PfGrp78, is a homologue of mammalian BiP (immunoglobulin-binding protein) or Grp78 (78 kDa glucose-regulated protein) (Kumar and Both PfHsp70-y and PfHsp70-z (PF07_0033) are phylogenetically close to members of the Hsp110/Grp170 protein family, which are specialised Hsp70s exhibiting NEF activity (Shonhai et al., 2007). As such these two

chaperones could act as NEFs in the ER and cytoplasm, respectively (Dragovic et al., 2006; Shonhai et al., 2007). Moreover, yeast two-hybrid studies propose interaction of Hsp40 homologue PF13_0102. Interestingly, proteomics analysis has detected PfHsp70-2 among the proteins present in the Maurer's clefts (Vincensini et al., 2005), which could be considered parasite ER-like structures in the erythrocyte cytoplasm. Furthermore, PfEMP1 has been identified as one of many proteins potentially interacting with PfHsp70-2 (LaCount et al., 2005), and again PfEMP1 is believed to transit by the Maurer's clefts on its way to the erythrocyte plasma membrane. Another *Plasmodium* Hsp70s that appears to contain an ER retain signal (KDEL) is PfHsp70-y (MAL13P1.540) (Table 2). Both PfHsp70-y and PfHsp70-z (PF07_0033) are phylogenetically close to members of the Hsp110/Grp170 protein family, which are specialised Hsp70s exhibiting NEF activity (Shonhai et al., 2007). As such these two chaperones could act as NEFs in the ER and cytoplasm, respectively (Dragovic et al., 2006; Shonhai et al., 2007). Moreover, yeast two-hybrid studies propose interaction of PfHsp70-z with PF07_0029, a *P. falciparum* Hsp90 (LaCount et al., 2005). PfHsp70-3 (PF11_0351) (Table 2) is a mitochondrial Hsp70 homologue, which is expressed in parasite blood stages (Sharma, 1992). It shows high homology with the human HspA9B a protein involved in protein export and antigen processing. Yeast two-hybrid analyses corroborate a similar role for PfHsp70-3, since a number of PEXEL containing proteins and malaria antigens were identified as possible interactors (LaCount et al., 2005).

Conclusion

The *P. falciparum* chaperone machinery is quite large and rather diverse especially considering the Hsp40s complement. This is not surprising if we consider that the parasite needs to modify the host cell in order to survive. The importance of chaperones is supported by the fact that chaperones are prominent in the PV, and many Hsp40s are predicted to be exported into the erythrocyte cytoplasm. However, direct experimental data on the cellular localisation of many Hsp40s is still lacking and for several Hsp40s only bioinformatic analysis may provide predictions of their localisation within and outside the parasite (Table 3). Beside a cytoprotective role, Hsp40s could be involved in protein trafficking and erythrocyte remodelling by interacting with host chaperones. Although bioinformatics, proteomics, and yeast two-hybrid studies can certainly help identifying potential roles of many Hsps, it is indispensable to experimentally validate such proposed functions. The recent study by Maier et al. (2008) linked some Hsp40s to erythrocyte remodelling and adhesion to the endothelium. Since the *P. falciparum* genome encodes several Hsp40s it is important to characterise more representative members of the Hsp40 protein family. Furthermore, in the Maier et al. (2008) stu-

dy, the effect of gene knock out might have been masked in some cases by redundancy in Hsp40s functions. To avoid this, double knock outs may represent a solution. This study also suggests that the unsuccessful disruption of certain genes may indicate that certain proteins are essential to the parasite for survival. One potential approach to study further this possibility could be the development of an inducible knock out system. Such strategy may also reveal at which developmental stage a specific gene, and therefore protein, is crucial. A major requirement to understand the role played by numerous Hsps is the identification of substrate proteins. As mentioned, protein-protein interaction networks have been proposed based on yeast two-hybrid analyses but experimental evidence is still lacking and for several Hsps there is no data. In a similar way, the protein-protein interaction networks that may occur in the infected erythrocyte have not been investigated yet and little or nothing is known about the potential interactions between parasite chaperones and host proteins.

ACKNOWLEDGMENTS

This work was funded by the National Research Foundation (NRF) and Medical Research Council (MRC) of South Africa. E.-R. P. was awarded a Claude Leon Postdoctoral Fellowship.

REFERENCE

- Aikawa M (1988). Human cerebral malaria. *Am. J. Trop. Med. Hyg.* 39: 3-10.
- Banumathy G, Singh V, Pavithra SR, Tatu U (2002). Host chaperones are recruited in membrane bound complexes by *Plasmodium falciparum*. *J. Biol. Chem.* 277: 3902-3912.
- Banumathy G, Singh V, Pavithra SR, Tatu U (2003). Heat shock protein 90 is essential for *Plasmodium falciparum* growth in human erythrocytes. *J. Biol. Chem.* 278: 18336-18345.
- Baruch DI, Pasloske BL, Singh HB, Bi X, Ma XC, Feldman M, Taraschi TF, Howard RJ (1995). Cloning the *P. falciparum* gene encoding PfEMP1, a malarial variant antigen and adherence receptor on the surface of parasitized human erythrocytes. *Cell* 82: 77-87
- Baruch DI, Ma XC, Singh HB, Bi X, Pasloske BL, Howard RJ (1997). Identification of a region of PfEMP1 that mediates adherence of *Plasmodium falciparum* infected erythrocytes to CD36: conserved function with variant sequence. *Blood* 90: 3766-3775.
- Bender A, van Dooren G, Ralph SA, McFadden GI, Schneider G (2003). Properties and prediction of mitochondrial transit peptides from *Plasmodium falciparum*. *Mol. Biochem. Parasitol.* 132:59-66.
- Bhattacharjee S, van Ooij C, Balu B, Adams JH, Haldar K (2008). Maurer's clefts of *Plasmodium falciparum* are secretory organelles that concentrate virulence protein reporters for delivery to the host erythrocyte. *Blood* 111: 2418-2426.
- Biswas S, Sharma YD (1994). Enhanced expression of *Plasmodium falciparum* heat shock protein PFHSP70-1 at higher temperatures and parasite survival. *FEMS Microbiol. Lett.* 124: 425-430.
- Botha M, Pesce E-R, Blatch GL (2007). The Hsp40 proteins of *Plasmodium falciparum* and other apicomplexa: Regulating chaperone power in the parasite and the host. *Int. J. Biochem. Cell Biol.* 39: 1781-1803.
- Bozdech Z, Llinás M, Pulliam BL, Wong ED, Zhu J, DeRisi JL (2003). The transcriptome of the intraerythrocytic developmental cycle of *Plasmodium falciparum*. *PLoS Biol.* 1: E5.

- Brown GV, Culvenor JG, Crewther PE, Bianco AE, Coppel RL, Saint RB, Stahl HD, Kemp DJ, Anders RF (1985). Localization of the ring-infected erythrocyte surface antigen (RESA) of *Plasmodium falciparum* in merozoites and ring-infected erythrocytes. *J. Exp. Med.* 162:774-779.
- Cheetham ME, Jackson, AP, Anderton BH (1994). Regulation of 70-kDa heat-shock-protein ATPase activity and substrate binding by human DnaJ-like proteins. HSP110 and HSP111. *Eur. J. Biochem.* 226: 99-107.
- Cheetham ME, Caplan AJ (1998). Structure, function and evolution of DnaJ: Conservation and adaptation of chaperone function. *Cell Stress Chaperones.* 3: 28-36.
- Craig A, Scherf A (2001). Molecules on the surface of *Plasmodium falciparum* infected erythrocyte and their role in malaria pathogenesis and immune evasion. *Mol. Biochem. Parasitol.* 115: 129-43.
- Cyr DM, Langer T, Douglas MG (1994). DnaJ-like proteins: molecular chaperones and specific regulators of Hsp70. *Trends Biochem. Sci.* 19: 176-181.
- Dragovic Z, Broadle SA, Shomura Y, Bracher A, Hartl FU (2006). Molecular chaperones of the Hsp110 family act as nucleotide exchange factors of Hsp70s. *EMBO J.* 25: 2519-2528.
- Ellis J (1987). Proteins as molecular chaperones. *Nature* 328: 378-379.
- Fan C-Y, Lee S, Cyr DM (2003). Mechanisms for regulation of Hsp70 function by Hsp40. *Cell Stress Chaperones* 8: 309-316.
- Feldman DE, Frydman J (2000). Protein folding in vivo: the importance of molecular chaperones. *Curr. Opin. Struct. Biol.* 10: 26-33.
- Fink AL (1999). Chaperone-mediated protein folding. *Physiol. Rev.* 79: 425-449.
- Flaherty KM, DeLuca-Flaherty C, McKay DB (1990). Three-dimensional structure of the ATPase fragment of a 70-K heat shock cognate protein. *Nature* 346: 243-282.
- Florens L, Washburn MP, Raine JD, Anthony RM, Grainger M, Haynes JD, Moch JK, Muster N, Sacci JB, Tabb DL, Witney AA, Wolters D, Wu Y, Gardner MJ, Holder AA, Sinden RE, Yates JR, Carucci DJ (2002). A proteomic view of the *Plasmodium falciparum* life cycle. *Nature.* 419: 520-526.
- Florens L, Liu X, Wang Y, Yang S, Schwartz O, Peglar M, Carucci DJ, Yates JR 3rd, Wub Y (2004). Proteomics approach reveals novel proteins on the surface of malaria-infected erythrocytes. *Mol. Biochem. Parasitol.* 135: 1-11.
- Freeman BC, Myers MP, Schumacher R, Morimoto RI (1995). Identification of a regulatory motif in Hsp70 that affects ATPase activity, substrate binding and interaction with Hdj-1. *EMBO J.* 14: 2281-2292.
- Han W, Christen P (2003). Mechanism of the targeting action of DnaJ in the DnaK molecular chaperone system. *J. Biol. Chem.* 278: 14426-14433.
- Hennessy F, Nicoll WS, Zimmermann R, Cheetham ME, Blatch GL (2005). Not all J domains are created equal: implications for the specificity of Hsp40-Hsp70 interactions. *Protein Sci.* 14: 1697-1709.
- Hiller NL, Bhattacharjee S, van Ooij C, Liolios K, Harrison T, Lopez-Estraño C, Halder K (2004). A host-targeting signal in virulence proteins reveals a secretome in malarial infection. *Science* 306: 1934-1937.
- Joshi B, Biswas S, Sharma YD (1992). Effect of heat-shock on *Plasmodium falciparum* viability, growth and expression of the heat-shock protein "PFHSP70-1" gene. *FEBS Lett.* 312: 91-94.
- Kelley WL (1998). The J-domain family and the recruitment of chaperone power. *Trends Biochem. Sci.* 23: 222-227.
- Kilejian A, Jensen JB (1977). A histidine-rich protein from *Plasmodium falciparum* and its interaction with membranes. *Bull. WHO* 55: 191-197.
- Kilejian A (1979). Characterization of a protein correlated with the production of knob-like protrusion on membranes of erythrocytes infected with *Plasmodium falciparum*. *Proc. Natl. Acad. Sci. USA* 76: 4650-3.
- Kooij TW, Janse CJ, Waters AP (2006). *Plasmodium* post-genomics: better the bug you know? *Nat. Rev. Microbiol.* 5: 344-357.
- Kumar N, Koski G, Harada M, Aikawa M, Zheng H (1991). Induction and localization of *Plasmodium falciparum* stress proteins related to the heat shock protein 70 family. *Mol. Biochem. Parasitol.* 48: 47-58.
- Kumar N, Zheng H (1992). Nucleotide sequence of a *Plasmodium falciparum* stress protein with similarity to mammalian 78-kDa glucose-regulated protein. *Mol. Biochem. Parasitol.* 56: 353-356.
- LaCount DJ, Vignali M, Chettier R, Phansalkar A, Bell R, Hesselberth JR, Schoenfeld LW, Ota I, Sahasrabudhe S, Kurschner C, Fields S, Hughes RE (2005). A protein interaction network of the malaria parasite *Plasmodium falciparum*. *Nature* 438: 103-7.
- Le Roch KG, Zhou Y, Blair PL, Grainger M, Moch JK, Haynes JD, De La Vega P, Holder AA, Batalov S, Carucci DJ, Winzeler EA (2003). Discovery of gene function by expression profiling of the malaria parasite life cycle. *Science* 301: 1503-1508.
- Lu Z, Cyr DM (1998). The conserved carboxyl terminus and zinc finger-like domain of the co-chaperone Ydj1 assist Hsp70 in protein folding. *J. Biol. Chem.* 273: 5970-5978.
- Marti M, Good RT, Rug M, Knuepfer E, Cowman AF (2004). Targeting malaria virulence and remodeling proteins to the host erythrocyte. *Science.* 306: 1930-1933.
- Matambo TS, Odunuga OO, Boshoff A, Blatch GL (2004). Overproduction, purification, and characterization of the *Plasmodium falciparum* heat shock protein 70. *Protein. Expr. Purif.* 33: 214-222.
- Nakai K, Horton P (1999). A program for detecting the sorting signals of proteins and predicting their subcellular localisation. *Trends Biochem. Sci.* 24:34-35.
- Nyalwidhe J, Lingelbach K (2006). Proteases and chaperones are the most abundant proteins in the parasitophorous vacuole of *Plasmodium falciparum*-infected erythrocytes. *Proteomics.* 6: 1563-1573
- Pachebat JA, Ling IT, Grainger M, Trucco C, Howell S, Fernandez-Reyes D, Gunaratne R, Holder AA (2001). The 22 kDa component of the protein complex on the surface of *Plasmodium falciparum* merozoites is derived from a larger precursor, merozoite surface protein 7. *Mol. Biochem. Parasitol.* 117: 83-89.
- Pavithra SR, Banumathy G, Joy O, Singh V, Tatu U (2004). Recurrent fever promotes *Plasmodium falciparum* development in human erythrocytes. *J. Biol. Chem.* 279: 46692-46699.
- Pesce E-R, Acharya P, Tatu U, Nicoll WS, Shonhai A, Hoppe HC, Blatch GL (2008). The *Plasmodium falciparum* heat shock protein 40, Pfj4, associates with heat shock protein 70 and shows similar heat induction and localisation patterns. *Int. J. Biochem. Cell Biol.* 40: 2914-2926.
- Rogerson SJ, Chaiyaroj SC, Ng K, Reeder JC, Brown GV (1995). Chondroitin sulphate A is a cell surface receptor for *Plasmodium falciparum*-infected erythrocytes. *J. Exp. Med.* 182: 15-20.
- Sargeant T, Marti M, Caler E, Carlton JM, Simpson K, Speed TP, Cowman AF (2006). Lineage-specific expansion of proteins exported to erythrocytes in malaria parasites. *Genome Biol.* 7: R12.-R12.22.
- Sharma YD (1992). Structure and possible function of heat-shock proteins in *Plasmodium falciparum*. *Comp. Biochem. Physiol. B.* 102: 437-444.
- Shonhai A, Boshoff A, Blatch GL (2005). *Plasmodium falciparum* heat shock protein 70 is able to suppress the thermosensitivity of an *Escherichia coli* DnaK mutant strain. *Mol. Genet. Genomics.* 4: 70-78.
- Shonhai A, Boshoff A, Blatch GL (2007). The structural and functional diversity of Hsp70 proteins from *Plasmodium falciparum*. *Protein. Sci.* 16: 1803-1818.
- Shonhai A, Botha M, de Beer TAP, Boshoff A, Blatch GL (2008). Structure-function study of a *Plasmodium falciparum* Hsp70 using three dimensional modelling and *in vitro* analyses. *Prot. Pep. Lett.* 15: 1117-1125.
- Smith JD, Chitnis CE, Craig AG, Roberts DJ, Hudson-Taylor DE, Peterson DS, Pinches R, Newbold CI, Miller LH (1995). Switches in expression of *Plasmodium falciparum* var genes correlate with changes in antigenic and cytoadherent phenotypes of infected erythrocytes. *Cell.* 82: 101-110.
- Su XZ, Heatwole VM, Wertheimer SP, Guinet F, Herrfeldt JA, Peterson DS, Ravetch JA, Wellem TE (1995). The large diverse gene family var encodes proteins involved in cytoadherence and antigenic variation of *Plasmodium falciparum*-infected erythrocytes. *Cell.* 82: 89-100.
- Suh W, Burkholder WF, Lu CZ, Zhao X, Gottesman ME, Gross CA (1998). Interaction of the Hsp70 molecular chaperone, DnaK, with its cochaperone DnaJ. *Proc. Natl. Acad. Sci. USA* 95: 15223-15228
- Suh WC, Lu CZ, Gross CA (1999). Structural features required for the interaction of the Hsp70 molecular chaperone DnaK with its cochap-

- erone DnaJ. *J. Biol. Chem.* 274: 30534-30539.
- Suthram S, Sittler T, Ideker T (2005). The *Plasmodium* protein network diverges from those of other eukaryotes. *Nature.* 438: 108-12.
- Szabo A, Langer T, Schröder H, Flanagan J, Bukau B, Hartl FU (1994). The ATP hydrolysis-dependent reaction cycle of the *Escherichia coli* Hsp70 system-DnaK, DnaJ and GrpE. *Proc. Natl. Acad. Sci. USA* 91: 10345-10349.
- Tsai J, Douglas MG (1996). A conserved HPD sequence of the J-domain is necessary for YDJ1 stimulation of Hsp70 ATPase activity at a site distinct from substrate binding. *J. Biol. Chem.* 271: 9347-9354.
- Vazquez de Aldana CR, Marton MJ, Hinnebusch AG (1995). GCN20, a novel ATP binding cassette protein, and GCN1 reside in a complex that mediates activation of the eIF-2 alpha kinase GCN2 in amino acid-starved cells. *EMBO J.* 14: 3184-3199.
- Vincensini L, Richert S, Blisnick T, Van Dorsselaer A, Leize-Wagner E, Rabilloud T, Braun Breton C (2005). Proteomic analysis identifies novel proteins of the Maurer's clefts, a secretory compartment delivering *Plasmodium falciparum* proteins to the surface of its host cell. *Mol. Cell Proteomics.* 4: 582-593.
- Wang T-F, Chang, J, Wang C (1993). Identification of the peptide binding domain of hsc70. 18-kilodalton fragment located immediately after ATPase domain is sufficient for high affinity binding. *J. Biol. Chem.* 268: 26049-26051.
- Watanabe J (1997). Cloning and characterization of heat shock protein DnaJ homologues from *Plasmodium falciparum* and comparison with ring infected erythrocyte surface antigen. *Mol. Biochem. Parasitol.* 88: 253-258.
- Young JC, Barral JM, Hartl FU (2003). More than folding: localized functions of cytosolic chaperones. *Trends Biochem. Sci.* 28: 541-547.
- Zuegge J, Ralph S, Schmuker M, McFadden GI, Schneider G (2001). Deciphering apicoplast targeting signals-Feature extraction from nuclear-encoded precursors of *Plasmodium falciparum* apicoplast proteins. *Gene.* 280:19-26