

Full Length Research Paper

Study of electrical properties of vegetable oils for the purpose of an application in electrical engineering

Khouloud LAKRARI^{1*}, Mouloud EL MOUDANE², Imane HASSANAIN¹, Imane ELLOUZI¹, Said KITANE³ and Mohamed ALAOUI EI BELGHITI¹

¹Laboratoire de Chimie Physique Générale, Département de Chimie, Université Mohammed V-Agdal, Faculté des Sciences, Avenue Ibn Batouta, BP 1014 Rabat.

²Laboratoire de Matériaux, Nanotechnologies et Environnement (LMNE), Département de Chimie, Université Mohammed V-Agdal, Faculté des Sciences, Avenue Ibn Batouta, BP 1014 Rabat.

³Laboratoires de chimie appliquée à l'Ecole Nationale de l'Industrie Minérale, Avenue Hadj Ahmed Cherkaoui BP 753 Agdal Rabat.

Accepted 25 September, 2013

The growing importance of the issues for sustainable development requires the consideration of environmental criteria in the development of all new materials and equipment. In the case of dielectric liquid, a better balance must be found between technical performance within the filled equipment and the impact on the environment always possible leaks. In transformers, a stable liquid, inert, with good electrical and thermal properties is necessary; outside, the liquid must be non-toxic to the environment and readily biodegradable. The intrinsic properties of natural vegetable oils in terms of fire resistance, environmental performance and electrical and thermal characteristics of dielectric compositions are particularly useful products in the field of electrical engineering. The objective of our work was to make a comparative study of different vegetable oils: Argan, Rapeseed, Sunflower and analyze the behavior of the electrical resistivity and viscosity as a function of temperature. This study may be useful for a possible application of these oils in technology.

Key words: Electrical resistivity, viscosity, vegetable oil, electrotechnical.

INTRODUCTION

The environmental impact of human activity causes increasing concern: the situation is worst between climate problems, pollution, overexploitation of resources and individual consumption, which are continually increasing. These developments make it necessary to consider practical and compatible solutions with sustainable development (Bozell and Patel, 2006).

The concept of green chemistry (Anastas and Warner, 1998) was created to "support the design of products and processes that reduce or eliminate the use and formation of hazardous substances." These eco-design rules some-

times seem restrictive, but they can be beneficial, especially for chemists and manufacturers. The principles of green chemistry tend to more environmentally friendly processes for the synthesis of the environment and the use of renewable raw materials (Baumann et al., 1988). Industrials (and financials) have logically turned to the substitution of fossil fuels with renewable raw materials, such as vegetable oils for biofuel sector. However, we must ensure that the consumption of vegetable oils for these new applications does not disturb the balance of existing networks, in particular those related to human

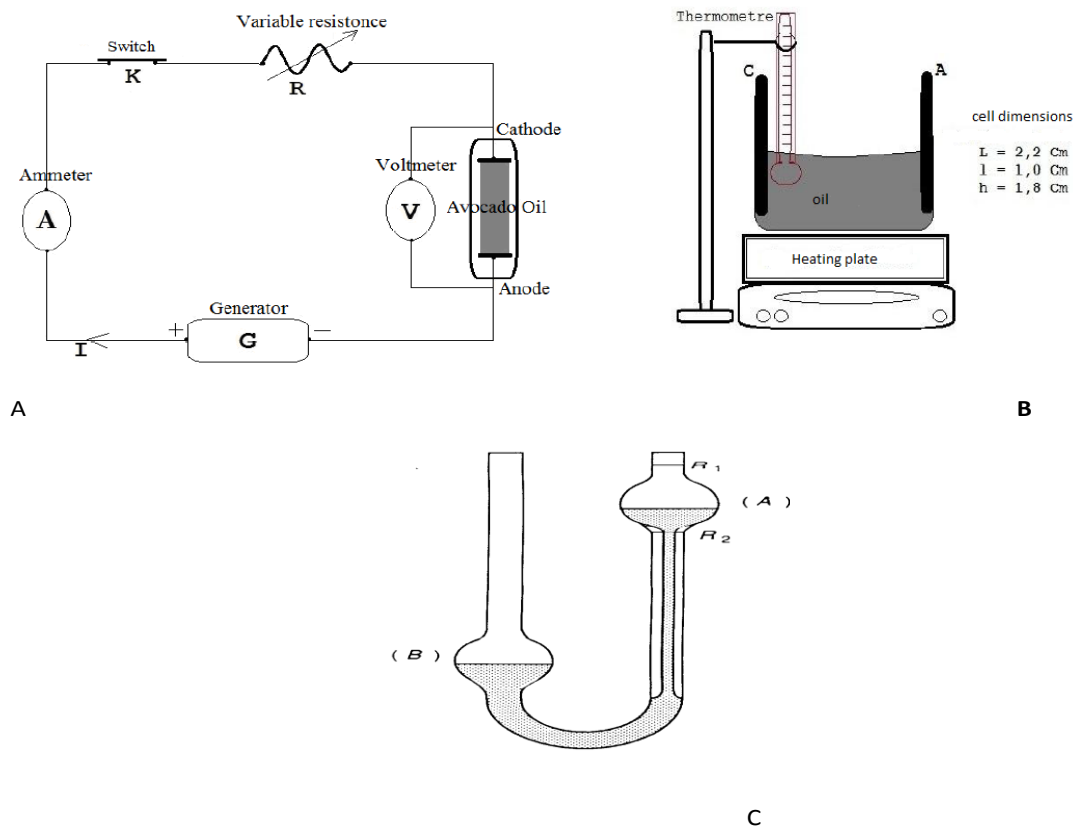

Figure 1. The diagram of the cell used to measure the electrical resistivity and viscosity. a. Construction of the used apparatus. b. Measurement of cell resistivity. C, Osswald viscometer.

consumption. Vegetable oils according to their fatty acid composition, have non-food applications. For example, azelaic acid and Pelargonic can be industrially produced by ozonolysis of oleic acid (Goebel et al., 1957), the majority fatty acid of olive oil, rapeseed and sunflower. Azelaic acid has pharmacological properties and is used in cosmetics and dermatology. The pelargonic acid is itself regarded as a by product of this reaction between and in the formulation of lubricants.

The oils are the main class of lubricants as well as the number of applications that the volume of lubricant used in the world (remember that fat is composed of 80 to 90% oil). Due to their natural affinity for metal surfaces and their viscosity, oil seep between the surfaces in relative motion and reduce friction, heat and wear.

Because of their chemical inertness when subjected to electric fields, oils are often used as electrical insulation for certain applications, including transformers, circuit breakers, cables, and capacitors.

For electrotechnical applications, in addition to electrical properties (rigidity, resistivity, and specific power inductor) are also sought good thermal properties.

Mineral oils, especially used at the beginning of electrical engineering, are now abandoned in favor of synthetic oils whose properties are much better for this type of application (Berger, 2002).

There are prototypes of biodegradable insulating oil for transformers based on derivatives of vegetable oils (fatty acids) and with unmatched performance at low temperatures. The biodegradability and non-toxicity of these insulating oils are substitutes choice for those that are commonly used in full based petrochemical derivatives, and therefore more prone to price fluctuations of petroleum products (Vitilingon et al., 1998) The application of vegetable oils in technology, requires a thorough study of their electrical and physical cleanliness (resistivity, viscosity etc.)

MATERIALS AND METHODS

Vegetable oils are generally very low toxics and have excellent biodegradability. These qualities are due in particular to a low resistance to oxidation and hydrolysis. Because of these two characteristics that are conducive to eco-toxicological aspects, plant oils are already used in distribution transformers and attempts are being made to expand their use in power transformers. (Darwin et al., 2007)

The vegetable oils: Argan, Rapeseed, Sunflower commercially available were purchased from the market.

The diagram of the cell used to measure the electrical resistivity is shown in Figure 1a and b. We used the method of resistivity measurement called "colon": the electrical resistance of the oil was determined by measuring the current and the potential difference

Measuring the Electrical Resistivity

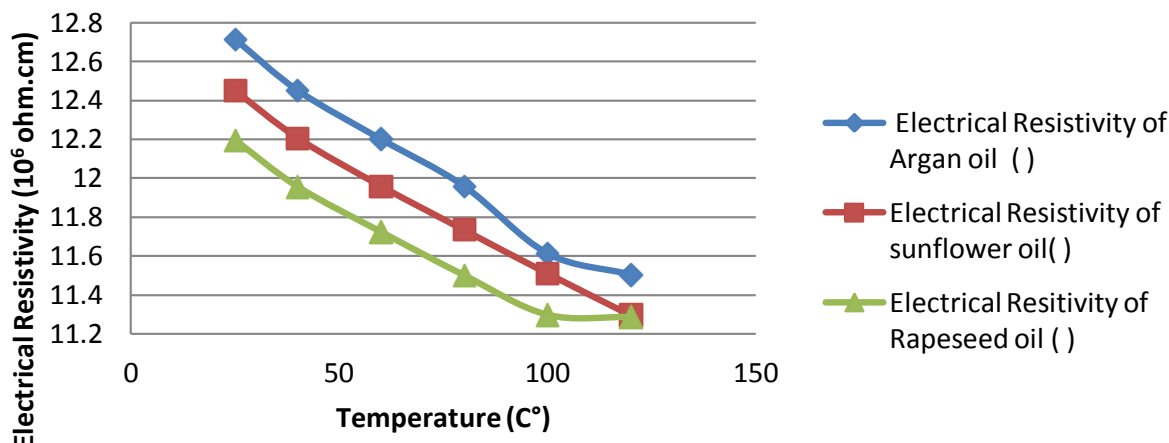

Figure 2. represents measurements of dynamic viscosity of vegetable oils: argan, rapeseed, sunflower.

(ddp) between the two electrodes of the cell. The viscosity WAS measured by a viscometer Osswald (Figure 1c):

Measurement of the electrical resistivity of vegetable oils

We used the following formula to measure the electrical resistivity (ρ):

$$\rho = R \times \frac{S}{L}$$

Where ρ is the resistivity ($\Omega \cdot \text{cm}$); S is the section (cm^2); L is the length (cm).

$S = l \times L$; $l = 1.1 \text{ cm}$; $L = 2.2 \text{ cm}$ (distance between the two electrodes).

Measurement of the dynamic viscosity of vegetable oils

Measuring the time of a flow of a volume V of fluid through a capillary tube, the kinematic viscosity is proportional to the flow time:

$$\nu = K \cdot \Delta t$$

The constant K of the device is given by the manufacturer of the viscometer.

RESULTS AND DISCUSSION

We studied the variation of the electrical resistivity and the dynamic viscosity as a function of the temperature of vegetable oils: Argan, rapeseed and sunflower, the results obtained are represented in Figures 2 and 3.

We observe that the electrical resistivity decreased with increasing temperature, this decrease can be explained by: 1) By the chemical various changes occurring in the

oil when heated; 2) the orientation of the molecules when the temperature increases (decrease in viscosity with increasing temperature) which promotes the flow of current in the oil. Tekin and Hammond (2000) studied the influence of temperature on the measurements of the electrical resistivity of soybean oil. These authors observed the same changes in resistivity as a function of temperature. Our results are in good agreement with those of Tekin and Hammond (2000).

The dependence of the viscosity of the fluid temperature is a manifestation of the behavior of cohesive energies and heat, with a rise in temperature, the attraction between polar molecules decreased while their thermal energy increased and the viscosity of the oil decreased.

Our measurements are in agreement with the measurements of Dilip et al. (2013) because the estimated coefficient by the author is very small so we can neglect it.

Measuring the electrical resistivity and the viscosity is a method for the control of the quality of oil and as an indicator of changes in new or oil in service resulting from contamination or damage.

We can conclude that the temperature facilitates when it increases the electrical conductivity and viscosity of the oils we studied. This study has allowed us to make a comparison of our results on the behavior of the resistivity and viscosity as a function of temperature with those of other researchers working on the same research topic (Pace et al., 1968; Risman and Bengtsson, 1971). Electrical measurements of oils that depend on the temperature can be used as a strong indicator of the deteriorating food quality oils at high temperatures.

The study of the viscosity and electrical resistivity of these oils can be useful for application in the field of technology (insulation, transformer etc). In perspective, we plan to complete our work by a study of the thermal resistivity as a function of temperature.

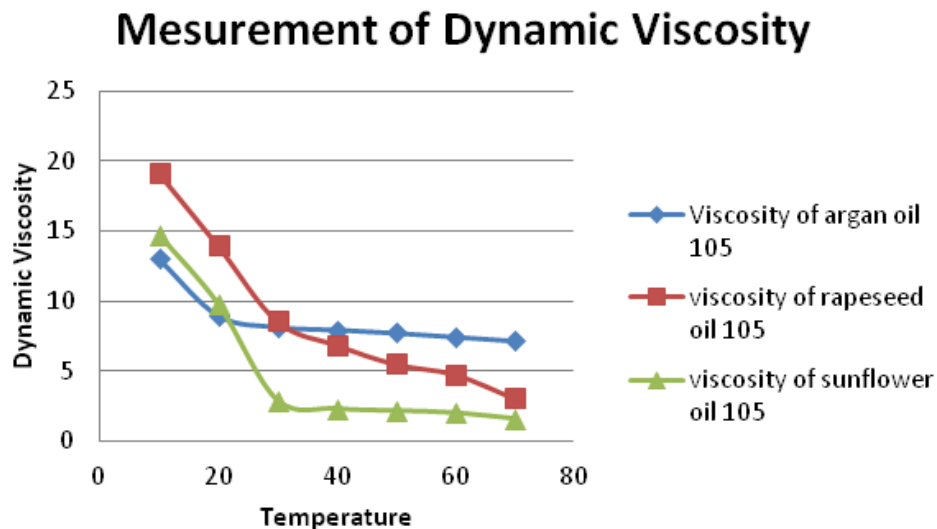

Figure 3. Measurements of dynamic viscosity of vegetable oils: argan, rapeseed, sunflower.

REFERENCES

- Anastas PT, Warner JC (1998). Green chemistry theory and practice, Edition Oxford University press.
- Baumann H, Bühler M, Fochem H, Hirsinger F, Zobelein H, Falbe J, Angew (1988). "Natural Fats and Oils –Renewable Raw Materials for the Chemical Industry. Chem. Int. Ed. Eng. 27:41-62.
- Berger N (2002). "liquids isolants en électrotechnique-caractéristiques des produits", techniques de l'ingénieur, Traité D2471, Novembre 2002, p. 24.
- Bozell JJ, Patel MK (2006). Feedstocks for the Future – Renewable for the Production of Chemicals and Materials, Edition American Chemical Society.
- Darwin A, Perrier C, Foliot P (2007). "The use of natural ester fluids in transformer", Proceedings of MATPOST conference, Lyon (France), Paper 0036: 15-16.
- Dilip K, Amarjit S, Paramjit ST (2013). Interrelationship between viscosity and electrical properties for edible oils. J. Food Sci. Technol. Goebel CG, Brown AC, Oehlschlaeger HF, Rolfes RP (1958). Method of making azelaic acid, Patent US 2813113, 1957. Chem. Abstr. 52:2431.
- Pace WE, Westphal WB, Goldbith SA (1968). Dielectric properties of commercial cooking oil. J. Food Sci. 33:30-36.
- Risman PO, Bengtsson NE (1971). Dielectric properties of foods at 3 GHz determined by cavity perturbation technique. J. Microw. Power. 6:101-106.
- Tekin A, Earl G. Hammond. (2000). J. Am. oil Chemists' Society. 77 (3): 281-283.
- Vaitilingom G, Perilhon Ch, Liennard A, Gandon M (1998). Development of rapeseed oil burners for drying and heating. Indus. Crops Prod. 7, 273-279.