

Full Length Research Paper

A new experimental system design related to the plasma state

S. D. Korkmaz

Eskisehir Osmangazi University, Elementary Science Education Department, Meşelik Campus, 26480- Eskisehir, Turkey.

Received 19 August, 2015; Accepted 10 September, 2015

The plasma state is included in the unit on matter and its properties in the 9th grade Physics course secondary school curriculum prepared by the Ministry of National Education of Turkey. Any tools and equipment required by tests to be conducted in the scope of the Physics course curriculum are in general easily accessible. However, in cases in which there are any physical or technical restrictions, it is suggested that different means such as demonstrations, tests or simulations are used. It is difficult to implement tests related to the plasma state of matter constituting the subject of this research due to technical restrictions. The goal of this study is to enable the student to understand the plasma state of matter that we encounter both in the universe and in daily life. To that end, an experimental system is designed for the plasma state of matter. To investigate the effect of this designed experimental system on understanding the plasma state, a working group was established with 48 students who studied in the 2014–2015 educational year in Eskisehir. Data are collected by an academic achievement test developed by the researchers. The achievement test is applied before and after the experimental procedure, and it is examined by t-test for unrelated samples. The answers given by the students to the open-ended questions are examined. According to the results of such a t-test for unrelated samples, it is found that the point averages received by the students from the achievement test after the experimental procedure are significantly higher than the point averages received by the students from the achievement test before the experimental procedure. Rubric scores for the answers given by the students to the open-ended questions show that the students explain their justifications better because of the experiment.

Key words: Secondary school students, physics education, plasma concept.

INTRODUCTION

In the antique phlogiston theory, states of matter include "soil," "water," "air" and "fire." Despite its basic defects, the phlogiston theory classifies states of matter in 4 groups: Solid, liquid, gas and plasma. Although it is

estimated that 99% of the matter in the universe is plasma, the significance and properties of the plasma state were only discovered in the 20th century (Johnson, Lectures in Plasma Physics).

E-mail: sduysal@ogu.edu.tr.

Authors agree that this article remain permanently open access under the terms of the [Creative Commons Attribution License 4.0 International License](https://creativecommons.org/licenses/by/4.0/)

Table 1. Plasma temperature and particle density (Johnson, Lectures in Plasma Physics).

Type of plasma	Particle density No/cm ³	Temperature T (K)
Interstellar Gas	1	10 ⁴
Solar Corona	10 ⁶	10 ⁶
Solar Atm. Gas Discharge	10 ¹⁴	10 ⁴
Diffuse Lab. Plasma	10 ¹²	10 ⁶
Dense Lab. Plasma	10 ¹⁴	10 ⁶
Thermonuclear Plasma	10 ¹⁶	10 ⁸

The plasma state, which was first defined by Irwin Langmuir as an ionized gas containing free particles in 1928, constitutes more than 99% of the universe (Langmuir 1928, Tonks and Langmuir, 1929). Examples of plasmas in the universe include the sun, other stars, solar winds, supernovas and nebulas; examples of plasmas on Earth include polar lights (Auroras), lightning flashes, fire, the ionosphere region of the earth, the magma stratum of the earth and the Van Allen belts. Furthermore, examples of plasmas generated *in vitro* include neon advertisement lamps created with modern technology, Xenon headlamps of vehicles and sodium vapor lamps (Grill, 1993; Elizer and Eliezer, 2001; CPEP, 2014; Tresman, 2014, ESOGU, 2014).

The reason we encounter the plasma state of matter very frequently is that it has different properties compared with other states of matter. Freedom of movement of particles increases as matter changes from a solid state to liquid and gas states and reaches the plasma state. In solids, atoms are arranged in a periodic crystal lattice and have no freedom of movement. In liquids, atoms are free. However, due to powerful interatomic interaction, their volumes remain unchanged, but not their shapes. In gases, atoms collide with other gas atoms as they move freely. If they continue to radiate heat in their gas state, ionization may begin. Ionization state means that at least one electron leaves an atom or molecule. In a sufficiently heated gas, ionization occurs repeatedly and free electron and ion clouds begin to form. However, particular atoms are stimulated and continue to remain neutral electrically, expelling their energy surplus and again becoming basic atoms by emitting photons. This medium, in which electrons in these atoms, ionized atoms and molecules, neutral atoms, stimulated atoms and molecules and photons exist together and interact permanently, is called "plasma." Plasma is collectively neutral (Grill, 1993; Elizer and Eliezer, 2001; Contemporary Physics Education Project [CPEP], 2014; Tresman, 2014, Eskisehir Osmangazi University [ESOGU], 2014).

The most important two plasma parameters are particle density (number/cm³) and temperature (K). Classification of plasmas based on these parameters is given in Table 1 (Johnson, 2014).

Plasma physics has been particularly driven by two grand challenges. The first is to understand the behavior

of natural plasmas in the universe. The majority of matter in the visible universe is in the plasma state. Behavior of the solar system is significantly determined by plasma physics. The Earth is embedded within a plasma (the ionosphere and magnetosphere); the solar wind transports plasma from the sun to the Earth, and the Sun is a plasma. Moreover, plasmas are key to behavior at all scales in the universe – from the plasma filling the interstellar medium to extra-galactic jets of plasma that emanate from disks surrounding black holes.

The second challenge is to develop fusion energy as an energy source to transform the way the world produces energy. This requires producing, controlling – and understanding – a plasma at a temperature of 100 million degrees confined by a magnetic field. The goal to produce fusion energy on Earth for electricity generation is often aptly described as producing a sun in a container. Magnetic fields are used for confinement since no solid material could withstand the extremely high temperature of the plasma. A minimum required value for the product of the plasma (electron) density n_e and the "energy confinement time" τ_E is given by the Lawson criterion (Lawson, 1955) which is an important general measure of a system that defines the conditions needed for a fusion reactor to reach ignition.

As recently reported in the National Research Council's report on Plasma Science, plasmas play an important role in developing many of today's advanced technologies (National Research Council [NRC], 2007). Although they are not very well-known by the general public, plasmas are used for most of high technology devices. Indeed, one of the main applications of plasma technology is related to micro and nanotechnologies. For instance, in a clean room of production of Integrated Circuits for memories or microprocessors, more than 50 % of the equipment consist of plasma reactors. Plasma technologies are also used for many other applications in materials industry (coating, functionalization), in chemical industry (gas abatement, gas production ...), in medical industry (plasma sterilization, plasma treatment...) and in many other industries (Liebermann and Lichtenberg, 1994). Hence, there is real value in teaching the basics of plasma physics to the next generation of scientists as early as possible (O'Brien et al., 2011). However, it is not particularly simple for a science or engineering undergraduate and high school student to obtain a qualitative

understanding of the basic properties of plasmas that exhibit a huge array of phenomena that challenge our ability to describe and understand collective behavior. Recently educational programs and collaboration projects between universities and plasma laboratories such as the Princeton Plasma Physics Laboratory (PPPL) started so plasma scientist can work with graduate and undergraduate students to teach basic properties of plasma and plasma technologies (Tillocher et al., 2015; Prager and Ono, 2014).

Teaching of plasma concept in Turkey

The Physics course curriculum in the high school was redesigned by the Ministry of National Education in 2013 to enable students to obtain knowledge and skills required for their university education and to develop the scientific literacy of students in Turkey (Ministry of Education [MoE], 2013). The physics course curriculum involving 9th and 10th grades includes basic concepts in the science of physics. At a basic level, the physics course curriculum in the 9th grade is a continuation of previous science courses. The course is aimed to enable students to explain any basic concepts related to matter, energy, force and motion included in the science of physics but without attempting any detailed mathematical operations in physics courses in the 9th grade.

The second unit of the 9th grade physics curriculum consists of 5 units including Matter and Its Properties, for which a time of 12 course hours is allowed. In this unit, the students at this grade level may understand, explain and syllogize any events and circumstances such as jewelry, porcelain, business, strength of creatures, ability of an insect to walk on a water surface, water absorption of paper napkins, lightning, and northern lights in daily life by using knowledge of matter and its properties. The last topic of the unit, "Matter and properties," includes Plasmas. This unit exemplifies and explains the general properties of plasmas and aims at ensuring that students learn related information.

However, it is not easy to ensure that high school students perceive the basic properties of plasma. Students must understand and be able to apply at least dynamic, electricity and magnetism and chemistry associated with the plasma state of matter to be able to perceive plasma and its properties. For students following the course curriculum of secondary schools as applied in Turkey, this is possible only when these students attain the 12th grade level.

To ensure that students acquire knowledge of plasma, lecturing must be supported by experiments. As stated in the physics curriculum of the high school, experiments are also important in the scientific process. The students must play an active role socially and cognitively to achieve the real goal of the experiments. Any tools and equipment required by experiments to be conducted in

the scope of the Physics course curriculum are in general easily accessible. However, in cases in which there are any physical or technical restrictions, it is suggested that different means such as demonstration experiments or simulations are used. It is difficult to implement experiments related to the plasma state of matter constituting the subject of this research in classroom due to technical restrictions and requirement of high voltage. Therefore, because in vitro tests are not conducted for feedback on the plasma state of matter described in the curriculum, return of such feedback on the plasma state of matter to the students is not possible.

Literature research shows that the experiments related to plasma state for high school students are limited only to plasma globe. In this study we designed an experimental system to enable the students to understand the plasma state of matter that we encounter both in the universe and in daily life. To the best of our knowledge, previously no one has reported such a study. To examine high school students' understanding of plasma concepts, a two tier test used by many researchers in the science education (Garnett and Treagust, 1992; Haslam and Treagust, 1987; Mann and Treagust, 1998; Treagust, 1988; Odom and Barrow, 1995; Voska and Heikkinen, 2000) owing to their features covering the deficiencies of multiple choice tests has been prepared and named Plasma Achievement test. Such tests are generally particular to a specific subject in any discipline (Uyulgan et al., 2014). It is thought that the two-tier test to be developed in the present study will be useful to determine the difficulties the students have in relation to the concepts of plasma as well as their misconceptions.

Aim of the study

The aim of this study is to ensure that high school students may perceive the plasma state, which is a state that exists widely in the universe and that is used to produce new products and generate energy today, and its general properties. A demonstration experiment designed in line with this aim was watched to the students, and the study examines the students to ascertain whether there is any change in their knowledge level on plasma from before to after the demonstration.

Research model

This study is a relational survey research, which aims at examining whether there is any significant change in the knowledge level of students on plasma from before to after a demonstration.

Working group

The working group of the research was established with

48 students, who studied in the 2014–2015 educational year in the Cumhuriyet High School, Eskisehir city.

Data Acquisition Tools

Plasma Achievement Test (PAT) (APPENDIX-1): The Plasma Achievement Test was developed as a 10-item instrument, with each item consisting of a two-tier multiple-choice test question. The first tier of each item was designed to examine students' content knowledge of a selected plasma concept, and the second tier included open-ended questions designed to examine students' reasons for answering the way they did for each first-tier question. It is expected that the students justify their answers to the open-ended questions similarly to how they justify answers given by them to multiple-choice questions. In preparing the test, the questions are developed to reveal knowledge of the secondary schools students teachers on plasma and to reveal how they use that knowledge. In developing the questions, it is considered that any knowledge on plasma the students have learned in 9th grade. Care is taken that plasma-related study materials previously available to the students include material covered by the test questions to ensure that validation of the test scope includes the questions in the test. Additionally, two measurement evaluation specialists, two physics teachers, one physical science specialist and one science teaching-specialist are consulted for their opinions.

Item analysis and reliability study of the PAT was carried out with 80 students studying in the two different high schools in Eskişehir in the 2014-2015 academic years. Item difficulty and item discrimination indices were calculated.

Table 2 gives the findings related to the results of the item analysis of the test developed in the research. According to these results, the discrimination indices of test items are higher than .30. Discrimination indices of the test items in the final form consisting of 10 items ranged between 0.36 and 0.91 while difficulty indices ranged between 0.15 and 0.83. At the end of the item analysis made, test-retest reliability coefficient of the 10-item test was found to be 0.81. This value shows that the test is highly reliable (Buyukozturk et al., 2008). A scaled scoring key is used that is prepared by asking two physicist and one measurement evaluation specialist for opinions on the scoring of the open-ended questions of the academic achievement test. Accordingly, the multiple-choice questions are scored so that they sum to 100 points, and the open-ended questions are scored so that they also shall sum to 100 points. In scoring, each question has an equal weight.

Procedure

A new experimental system is designed as a demonstra-

Table 2. Item analysis of PAT.

Item	P	r_{jx}
1	.83	.41
2	.35	.55
3	.31	.77
4	.58	.91
5	.19	.36
6	.38	.59
7	.48	.59
8	.15	.36
9	.24	.55
10	.33	.45

tion experiment in accordance with the goal of the study. As a pre-test, the PAT is given to the students one week prior to the demonstration experiment.

In the demonstration experiment, Neon Lights and Other Discharge Lamps and simulations are monitored (PHET, 2014), and then PAT is given again as a post-test.

Experimental system

The experimental system shown schematically in Figure 1 consists of 7 different gas-pressure discharge tubes shown as (7) in the figure and a plasma stick. With the plasma stick shown as (5) in the figure, a potential having a relatively frequency (20 kHz) is generated between 5 kV and 10 kV by using the grid voltage. When any frequency-type power supplies are operated, it is possible to transmit energy into the tube without any electrodes within the discharge tubes. Such a discharge operation is called "electrodeless discharge." An variable electrical field occurs at the end of the plasma stick with a frequency-type power supply. When the plasma stick is brought near the discharge tubes (position (6) in the figure) the electrical field flow increases. The variable electrical field ensures that the particles vibrate within the discharge tube. Ions increasing suddenly within the tube are forced to collide with one another and with un-ionized gas atoms within the tube. The collisions cause stimulations and ionizations to begin. In this case, luminosity is observed in the tube (electrodeless discharge). Because gas pressures and gas types are different in the tubes, different color plasmas occur. We may explain to the students why plasmas occur in different colors because different colors occur visually.

Because the plasma stick is isolated by a glass tube, it is disconnected directly from the discharge tubes. Thus, the teacher and students may contact the tubes safely; furthermore, the teacher may demonstrate a wireless and contact-free energy transfer to the students. If any tube is contacted once the discharge tubes begin to light up, a sudden increase in intensity of the luminance occurs.

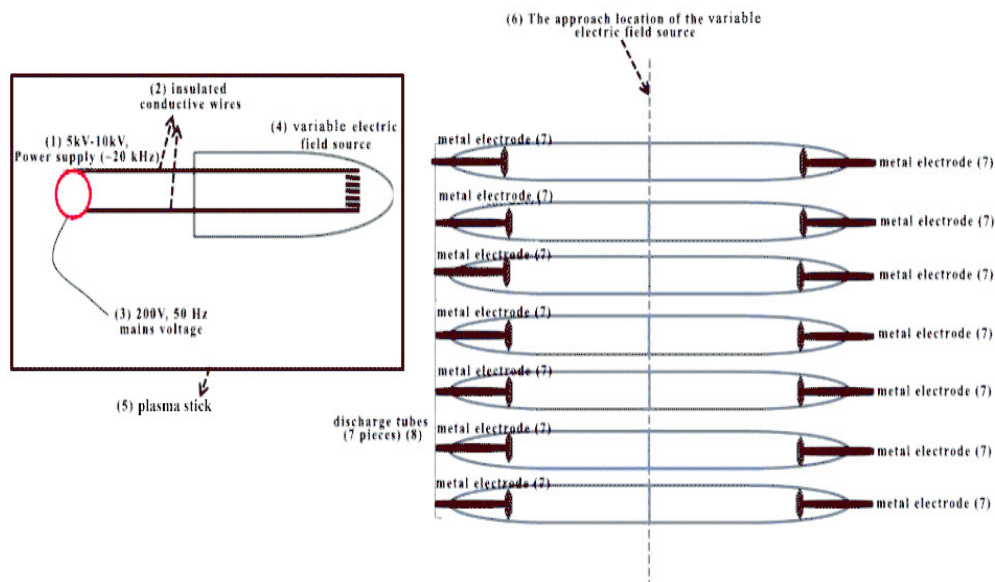

Figure 1 Schematic diagram of experimental set-up.

This is why the electrical field intensifies suddenly. Thus, any contacting person serves as a ground.

As seen Figure 2, in the discharge tubes filled with 7 different gases, there are also electrodes to serve as anodes and cathodes. These electrodes are used to show that flow passes from one end to the other, and thus electrical conductivity of the plasma is demonstrated.

Any physical topics and concepts such as Atom models, Light, Photon, Color, Stimulation, Ionization, Electromagnetic spectrum, magnetic field and interaction of the plasma are explained to the students. It is thus ensured that the students in 9th grade have knowledge of this experimental system. The simulations to be used are designed to have a flexible nature and are designed for the students. Thus, it is intended that the students understand the specific concepts in the 10th, 11th and 12th grades of the secondary education program.

Data analysis

In preparing the data for analysis, each multiple-choice question is normally scored as 1 for each correct answer and as 0 for each incorrect answer. Then, the total number of correct answers of each student is calculated for the pre-test and the post-test. Interpretations are made considering the number of correct answers.

In scoring justifications for answers given by the undergraduates to the multiple-choice questions, each question is scored relative to perfect scores by means of a scaled scoring key.

Answers given by the students to the multiple-choice and open-ended questions in the test are examined via a



Figure 2. Experimental set-up.

frequency analysis. The answers then are examined in terms of score differences between pre-test and post-test scores. Finally, whether the score differences meet the normality hypothesis is determined. To that end, the Shapiro-Wilk normality test is applied, determining that the distribution of score differences differs excessively from the normal distribution for both the multiple-choice questions and the justifications ($p > .05$). Accordingly, a t-test is used as a parametrical test for correlated samples in average comparisons.

FINDINGS

Descriptive statistics are calculated for the pre-test and post-test scores of the students and presented in Table 3. The pre-test scores of the students have a point average

Table 3. Descriptive statistics for pre-test and post-test scores

	N	Min	Max	Mean	Std. Deviation
Pre-test	48	.00	6.00	2.54	1.49
Post-test	48	.00	8.00	4.21	2.04

Table 4. Correct and incorrect answers to the questions in pre-test and post-test.

Item	Pre-test		Post-test		DIF
	Correct	Incorrect	Correct	Incorrect	
1	34	14	42	6	8
2	14	34	18	30	4
3	7	41	23	25	16
4	22	26	23	25	1
5	2	46	7	41	5
6	6	42	12	36	6
7	17	31	33	15	16
8	5	43	12	36	7
9	3	45	21	27	18
10	12	36	11	37	-1

of approximately 2.54, and the post-test point average score of the students is 4.21. The numbers of correct and incorrect answers given to the questions are calculated and given in Table 4. The students reach a larger number of correct answers in the post-test, particularly on the 3rd, 7th and 9th questions with respect to properties.

The physics course in 9th grade of the secondary school includes the following sections on plasma:

Section 9.2.4.1 explains the general properties of plasmas by giving examples:

a explains that plasma is a state of matter such as solid, liquid and gas; and

b explains the general properties and structures of plasmas, with examples from daily life.

The 3rd, 7th and 9th questions measure the information set forth in 9.2.4.1.b, whereas first question measures the information set forth in 9.2.4.1.a. The demonstration experiment and simulations do affect learning.

The paired-samples t-test is implemented to determine whether there is a considerable difference statistically between point averages scored by the students in the Plasma Achievement Test (PAT) before and after the demonstration experiment. Test results are given in Table 5.

The post-test point averages ($\bar{X} = 4.21$) scored by the students in the PAT test are significantly higher than the test point averages ($\bar{X} = 2.54$) scored by the students in the PAT pre-test ($t_{47} = -6.245$; $p < .05$). The effect size is calculated to determine whether this distance is also significant in practice, and it is found that Cohen's d is

Table 5. PAT pre-test and post-test paired-samples t-test results.

Test	N	\bar{X}	S	df	t	p
Pre-test	48	2.54	1.49	47	-6.245	.000
Post-test	48	4.21	2.04			

Table 6. Descriptive statistics for pre-test and post-test scores on essay-type questions.

	N	Min	Max	Mean	Std. Deviation
Pre-test	48	.00	23.00	10.46	7.63
Post-test	48	.00	31.00	14.69	6.83

Table 7. PAT essay-type questions pre-test and post-test paired-samples t-test results.

Test	N	\bar{X}	S	df	t	p
Pre-test	48	10.46	7.63	47	-3.660	.001
Post-test	48	14.69	6.83			

equal to -.935. This value shows that the difference in average has a wide effect size.

The answers given by the students to the open-ended questions are scored, and descriptive statistics for the scores are given in Table 6.

In Table 6, the students have a point average of 14.69 points out of a total of 100 points on the post-test, whereas they have a point average of 10.46 out of a total of 100 points on the pre-test. A t-test is conducted for relational samples to determine whether the variation between them is significant. The results are given in Table 7.

In Table 7, student scores on the answers given on the open-ended questions increase significantly ($p < .05$). Calculating the Cohen d coefficient obtains a value of -.584. This value shows that the students have a medium effect size on the increase in the average points from pre-test to post-test.

Discussion and Conclusion

In the present study an experimental system was designed to enable the students understand the plasma state of matter that we encounter both in the universe and in daily life. As stated before, literature research shows that the experiments related to plasma state for high school students are limited only to plasma globe. In order to check the effect of this designed experimental system on understanding the plasma state, we have started a qualitative study with gifted high schools students to obtain their opinion about our system.

It was concluded in the research that the Plasma achievement test developed in relation to plasma concept was sufficiently reliable and valid to reveal the conceptual comprehension levels of high schools students on this subject. The results of the item analysis of the test showed that discrimination and difficulty indices of the items were acceptable.

The analysis shows a low knowledge level on plasma of the student group examined in this study. The post-test point averages of the students are considerably higher than their pre-test point averages. This increase in the post-test points is observed both in multiple-choice questions and in open-ended questions. In this case, it may be interpreted that the students may justify their answers better after the demonstration experiment.

Examining the correct answers given by the students to the multiple-choice and open-ended questions, it appears that the students provide correct answers to the third, seventh and ninth questions but cannot justify their correct answers. By the nature of the multiple-choice questions, all options are provided to a person taking the test, and that person is expected to find and check correct answers among the options. In the open-ended questions, the person must provide the correct information to earn a point on the question. Therefore, on the third, seventh and ninth questions, they cannot justify why they check the answer, whereas the students may find and check correct answers on the questions. This behavior shows that the students do not comprehend the basic properties of plasma sufficiently.

When the third, seventh and ninth questions are examined, it is understood that these questions relate to the basic properties of the plasma and to natural and artificial plasma samples; these questions measure any knowledge acquired on plasma in the physics course curriculum in 9th grade of the secondary school. Thus, the simulations and the recently designed demonstration experiment, which constitutes the subject of this study, affect learning.

Although the students show higher success in the last test conducted upon the demonstration experiment and shown simulations, the fact that the average of the academic achievement test is low reveals that the plasma topic is not understood sufficiently. The students must learn topics such as electricity and magnetism associated with the plasma state of matter, modern atom theory, atomic stimulation and ionization to perceive plasma and its properties. In Turkey, description of these topics is completed in the physics course curriculum in 12th grade of the secondary school. This study reveals that if the plasma state is explained to the students before they study these topics related to the plasma state of matter, the students will experience problems with understanding the plasma state of matter and misunderstand much of what is taught. Research that we have conducted with candidate elementary science teachers in 3rd grade shows that the structure and properties of the plasma state are not easily understandable topics without the

necessary physical background (Korkmaz et al., 2015).

Based on the findings of this study, the following suggestions may be given:

1. Any subjects related to at least dynamics, electricity and magnetism of the plasma state and modern atom theory in the unit "structure and properties of matter" in the 9th grade physics course curriculum of the secondary school must be transferred to the curriculum in the 12th grade.
2. The plasma concept must be supported by experiments and simulations when it is discussed.
3. Although it was determined that the testing equipment set up for this study increased the scores by the students both from multiple-choice and open-ended questions significantly, it is observed that the students cannot justify any answers given to any particular questions. In the light of qualitative studies, the testing equipment to be set up for plasma instruction should be arranged so that students may learn better. A qualitative research mode may be investigated with answers given by the students to the open-ended questions.

Conflict of Interests

The author has not declared any conflict of interests.

ACKNOWLEDGMENTS

This study was supported by the Eskisehir Osmangazi University Scientific Research Projects Committee (Project No: 201421027). The authors gratefully acknowledge the financial support from the organization.

REFERENCES

- Buyukozturk Ş, Cakmak EK, Akgun OE, Karadeniz Ş, Demirel F (2008). *Scientific research methods*. Ankara: PegemA Publishing.
- Contemporary Physics Education Project [CPEP]. (2014). <http://www.cpepweb.org/>
- Elizer S, Eliezer Y (2001). *The Fourth State of Matter An Introduction to Plasma Science*. IOP publishing.
- Eskisehir Osmangazi University [ESOGU]. (2014). *Plasma science and technologies lab home page*. <http://esoguplazma.ogu.edu.tr>,
- Garnett PJ, Treagust DF (1992). Conceptual difficulties experienced by senior high school students of chemistry: Electro-chemical (galvanic) and electrolytic cells. *J.Res. Sci.Teach.*29 (10):1079-1099.
- Grill, A. (1993). *Cold Plasma in Materials Fabrication From Fundamentals to Applications*. IEEE Press: New york.
- Haslam F, Treagust DF (1987). Diagnosing secondary students' misconceptions of photosynthesis and respiration in plants using a two-tier multiple choice instrument. *J.Biol.Edu.*21 (3):203-211.
- Mann M, Treagust DF (1998). A pencil and paper instrument to diagnose students'conception of breathing, gas exchange and respiration. *Australian Sci. Teach.J.* 44 (2):55-59.
- Johnson PW (2014). *Lectures in Plasma Physics*. Chicago, Illinois.
- Korkmaz SD, Aybek EC, Pat S (2015).The effect of a new experimental system design related to the plasma state on achievement of candidate elementary science teachers.,*7th World Conference on Educational Sciences, (WCES-2015)*, Athens, GREECE

- Langmuir I (1928) "Oscillations in Ionized Gases," Proc. Nat. Acad. Sci. 14, 627,
- Lawson JD (1955). "Some Criteria for a Power producing thermonuclear reactor" Atomic Energy Research Establishment, Harwell, Berkshire, U. K. A.E.R.E. GP/R 1807.
- Liebermann MA, Lichtenberg AJ (1994). Principles of plasma discharges and materials processing, John Wiley and sons Inc.
- Ministry of Education [MoE]. (2013). *High school physics course curriculum*. Ankara.
- National Research Council [NRC] (2007). *Plasma Science: Advancing Knowledge in the National Interest*. Washington, DC: National Academy Press.
- O'Brien DA, Zhu W, Lopez JL (2011). Student Experiences with Plasma Phenomena, *IEEE Transacti. Plasma Sci.* Vol. 39, No. 11, 2584-2585.
- Odom AL, Barrow LH (1995). Development and application of a two-tier diagnostic test measuring college biology students' understanding of diffusion and osmosis after a course of instruction. *J.Res.Sci. Teach.* 32 (1):45-61.
- Prager S, Ono Y (2014). *A Tokyo/Princeton Educational Partnership in Plasma Physics*
http://www.princeton.edu/international/doc/Prager_Ono-2014_15-PU_UTokyo-Proposal-PR.pdf
- Tillocher T, Aubry O, Boufendi L, Pichard C, Lefaucheux P, Dussart R, (2015) *Engineering and research education in Plasma technology*, 43rd Annual SEFI Conference June 29 - July 2, 2015Orléans, France
- Tonks L, Langmuir I (1929) "Oscillations in Ionized Gases," Phys. Rev. 33, 195,
- Treagust, D.F.(1988). Development and use of diagnostic tests to evaluate students' misconceptions in science. *International J. Sci. Edu.*, 10 (2):159-169.
- Tresman I (2014). *The Plasma Universe Wikipedia-like Encyclopedia*. <http://www.plasma-universe.com/Plasma-Universe.com>,
- Uyulgan MA, Akkuzu N, Alpat Ş (2014). Assessing the students' understanding related to molecular geometry using a two-tier diagnostic test. *J.Baltic Sci.Edu.* 13 (6):839-855.
- Voska KW, Heikkinen HW (2000). Identification and analysis of student conception used to solve chemical equilibrium problems. *J.Res.Science Teach.* 37 (2):160-176.
- PHET. (2014). *Interactive simulations*.
<https://phet.colorado.edu/tr/simulations/category/physics>

Appendix 1. Plasma Achievement Test.**Dear students:**

This test consists of 10 questions. Each question has two steps. A multiple-choice question constitutes the first step of each question, and another question, which requires describing reasons for the answer given to that question, constitutes the second step.

Any clear and understandable answers that you give to the questions will provide us critical hints on new educational and teaching techniques. The answers that you give will not affect your grade and will be kept confidential.

We thank you for your participation and wish you success.

S - 1. How many states of matter exist in the universe?

- A) 3 B) 4 C) 5 D) 6 E) 7

Type your reason for S – 1 briefly.

S - 2. I. Gases are not affected by magnetic and electrical fields, but plasmas are affected by magnetic and electrical fields.

II. Because the distance between molecules of gases is large, gases do not conduct heat well, but plasmas do conduct heat well.

III. Gases and plasmas do not conduct electricity.

Which of the above phrases is/are true?

- A) Only I B) Only II C) Only III D) I and II E) I and III

Type your reason for S – 2 briefly.

S - 3. I. It consists of ionized and excited atoms.

II. Because it has an equal number of positive charges (ion charges) and negative charges (electrons), it is neutral electrically.

III. It consists of an ionized gas.

Which of the above phrases about the plasma state of matter is/are true?

- A) Only I B) Only II C) Only III D) I and II E) I, II and III

Type your reason for S – 3 briefly.

S - 4. An atom:

I. Can be heated and excited.

II. Can be excited by electromagnetic waves (photons).

III. Can be excited by electron bombardment.

Which one/s of the above consideration is/are true?

- A) Only I B) Only II C) Only III D) II and III E) I, II and III

Type your reason for S – 4 briefly.

Appendix 1. Contd.

S - 5. When a high voltage is applied to both ends of a glass tube containing a low-pressure gas, the tube emits light (e.g., neon lights in billboards).

What is/are physical reason/s for this radiation?

- A) Due to the applied high voltage, atoms in the tube combine and form molecules. Meanwhile, the liberated energy is seen as a light.
- B) Caused by collisions, the order of electrons of atoms in the tube changes, and atoms radiate when they restore to their original state.
- C) Due to a potential difference applied to the ends of the tube, a current passes through the tube. This current causes radiation just as with wired bulbs.
- D) Electrons moving inside the tube radiate.
- E) Positive ions moving inside the tube radiate.

Type your reason for S – 5 briefly.

S - 6. Which of the following definitions of plasma is incorrect?

- A) It is a stimulated state of gas.
- B) It is a warmed state of gas.
- C) It is a high-energy state consisting of ions, neutral atoms, free electrons and photons.
- D) It is a state at a vaporization point.
- E) It is a state at a sublimation point.

Type your reason for S – 6 briefly.

S - 7. Which one of the following items is not an example of plasma?

- A) Lightning
- B) Incandescent lamp
- C) Flash
- D) Fluorescent lamps
- E) Matter in the Sun

Type your reason for S – 7 briefly.

S - 8. In which of the mechanisms shown in the right figure can the lamp be expected to emit light?

- A) Only I
- B) Only II
- C) Only III
- D) I and II
- E) II and III

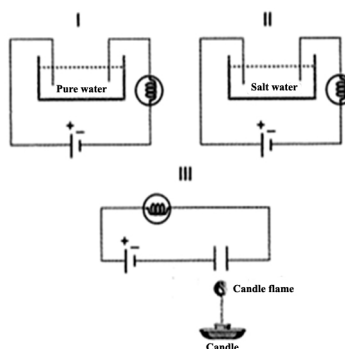

Type your reason for S – 8 briefly.

Appendix 1. Contd.

<p>S - 9. Which of the following phrases is/are true?</p> <p>I. Fluorescent and neon lamps are examples of plasma produced in vitro. II. Solar wind is an example of plasma in space. III. Auroras are examples of plasma occurring on the Earth.</p> <p>A) I and II B) II and III C) Only III D) I and III E) I,II and III</p>
Type your reason for S – 9 briefly.
<p>S - 10. I. Energy production with plasma is cleaner and causes less damage to the environment. II. Plasma technology is used in industry and in removal of bacteria and other microorganisms. III. Plasma in stars is called “hot plasma.”</p> <p>Which one/s of the above consideration is/are true?</p> <p>A) I and II B) I and III C) II and III D) I, II and III E) Only III</p>
Type your reason for S – 10 briefly.

ANSWER KEY TO THE ACADEMIC SUCCESS TEST

1. B
2. D
3. E
4. E
5. B
6. C
7. B
8. E
9. E
10. D