

Full Length Research Paper

Population structure and fishing of the greasyback shrimp (*Metapenaeus ensis*, De Haan, 1844) by bag net in a coastal river of the Mekong Delta, Vietnam

Tran Van Viet^{1,2} and Kazumi Sakuramoto^{2*}

¹College of Aquaculture and Fisheries, Can Tho University, Vietnam.

²Department of Ocean Sciences, Faculty of Marine Science, Tokyo University of Marine Science and Technology, 4-5-7, Konan, Minato, Tokyo 108-8477, Japan.

Accepted 22 April, 2013

The greasyback shrimp (*Metapenaeus ensis*) was studied in My Thanh River in Soc Trang Province, in the coastal region of the Mekong Delta in 2010. The bag net was used in the study; it had conducted six rounds of sampling (February, April, June, August, October, and December) at six stations along 30 km of river from the estuary at 6 km intervals. Besides, survey data also involved 36 fishermen, who are operating the bag net. Results showed that *M. ensis* was caught year-round. Carapace length (CL) was in the range 14.0 to 35.5 mm, but only 8% of *M. ensis* were in the largest cohort (CL > 28.3 to 35.5 mm), which was observed in June to August, whereas 36% were in the smallest cohort (14.0 to 21.1 mm) in August to February. The remaining 56% of shrimp, with CL 21.2 to 28.3 mm, CL and yield showed very weak correlations with salinity, depth, and transparency (R^2 ranging from -0.036 to 0.36). Yield was affected by time of year (different months) and was higher in the rainy season than in the dry season ($P < 0.05$). However, it did not differ across the various localities along the river ($P > 0.05$). The proportion of females was affected by various stations along the river during the various seasons ($P < 0.01$).

Key words: Bag net, greasyback shrimp, *Metapenaeus ensis*, carapace length, My Thanh River, Mekong Delta.

INTRODUCTION

The greasyback shrimp (*Metapenaeus ensis*) is a commercially important, brackish-water crustacean species (Chu et al., 1995), widely distributed in many Asian countries (Chu and So, 1987). It is a bottom-living species and can be found inshore at depths of < 3 m and offshore at depths of > 65 m. It occurs on muddy bottoms in estuaries and coastal waters, including river, canals, and swamps (Ministry of Fisheries, 1996; Holthuis, 1980), at salinities of 5 to 30 ppt (Kungvankij and Chua, 1986).

There is high demand for this species in Vietnamese markets and in many countries throughout the world

because of the high quality of its meat (Liao and Chao, 1983). In Vietnam, *M. ensis* is exploited at various life stages, from the post larval to sub-adult and adult stages, in the brackish waters of coastal area (rivers, canals, and shrimp farms in mangroves) with many kinds of small-scale equipment, including barrier nets, cast nets, trap nets, and bag nets. The bag net is commonly used to catch *M. ensis* in rivers.

The bag net is artisanal equipment that has been used for a long time, and contributes significantly to enhancing the incomes and domestic daily food supplies of local

*Corresponding author. E-mail: sakurak@kaiyodai.ac.jp. Tel/Fax: 81-3-5463-0563.

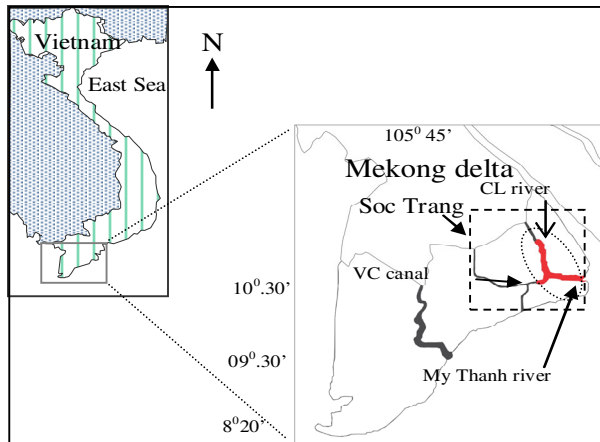

Figure 1. Maps showing the locations of Vietnam, the Mekong Delta, and the study site at the My Thanh River, Cai Lon River (CL River), and Vinh Chau canal (VC canal).

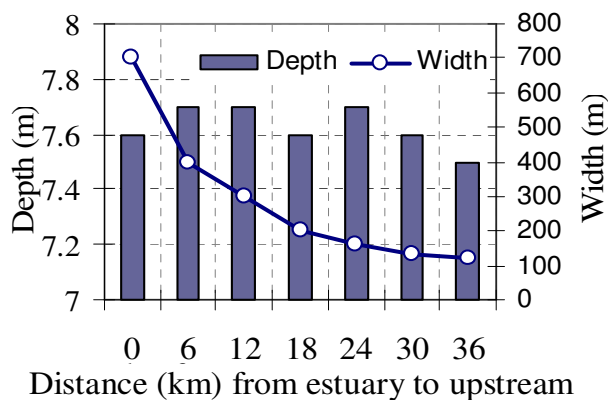

Figure 2. Depth and width of the My Thanh River from the estuary to 36 km upstream of the estuary.

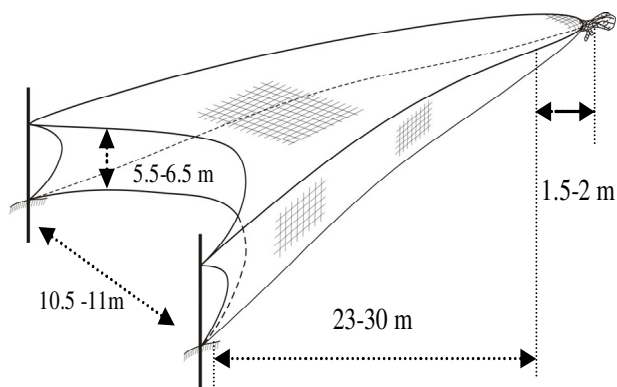

Figure 3. Schematic of a bag net, as used in this study.

residents. The Food and Agriculture Organization (FAO) (2002) found that small-scale fishing has little effect on aquatic resources, but provides an important source of

food and income for coastal communities worldwide, comprising 85% of fisheries in Asia.

Aquatic resources have an important function for rural communities in the Mekong Delta, which has high-density canal and river networks (Hung, 2009); the region is considered to have great potential for the development of natural aquatic resources (Ministry of Fisheries, 1996).

M. ensis has been exploited for several generations in this region, but the dynamics and yields of this species are unknown, scientific information is limited by lack of research. The fishing activities of fishermen depend on their experience, but information about this species is not underpinned by scientific data. The aim of study was to determine the population structure and the effects of environmental, temporal (month), and spatial (depth, distance from the estuary) parameters on the size, yield, and sex ratios of *M. ensis* in the context of fishing with bag nets in a coastal river. The results should provide initial information about *M. ensis* for fisheries managers, so that they can establish programs that will protect and develop this species in a large proportion of fisheries in the coastal region of Vietnam.

MATERIALS AND METHODS

Time and location

The study was performed in February to December, 2010, in Soc Trang Province, it is located at 8°30' to 11°N, 104°30' to 107°E in the coastal region of the Mekong Delta of Vietnam (Figure 1). The My Thanh is the main river of this province; the river has a muddy bottom and transparency of 1.0 to 5.0 cm (Department of Natural Resources and Environment of Soc Trang, 2009). Besides, this river is also affected both of brackish water from the estuary and freshwater moving downstream in the Mekong River, so the ecology of the river changes with the seasons (Hung, 2009). The width and depth of the river are shown in Figure 2.

Materials of the study

The bag net is the fishing equipment used in the river, in places with currents at ebb tide, when water moves downstream. Each bag net is fixed at a specific site and the net is supported by two columns Figure 3. Each net is designed so that the mesh size decreases in 7 to 8 m sections along the length of the net, with the largest mesh at the mouth of the net (2a = 3.5 cm), becoming gradually smaller to the end of the net (3, 2.5, 2, and 1.5 cm at the cod end). The total length of the bag net is 26.5 to 32 m, with a height of 5.5 to 6 m and width of 10 to 11 m.

The distance between two rows of bag nets is 1 km, and each row of bag nets contains many bag nets, it extends across the river, number of bag-nets depend on the width of the river (transect), often with 5 to 23 bag nets per the row net (transect).

The salinity of the river is also affected by the distance from the estuary, because there is an interaction between the salinity from the estuary moving upstream on the flood tide and the freshwater flow downstream at the ebb tide, salinity in different locations along river is shown in Figure 4.

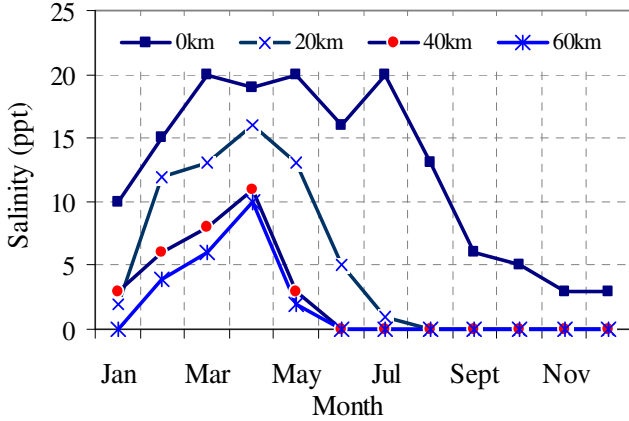

Figure 4. Salinity of the My Thanh river, Cai Lon River, and Vinh Chau canal at various distances from the estuary for each month of the year (Statistical Book of Soc Trang Province, 2009).

Data collection

Survey data

The survey data was collected from 36 fishermen (12 stations), who directly operated the bag nets on the river at several distances from the estuary. Three fishermen who each owned three bag nets were randomly selected at each station. These fishermen have operated this fishery in this region for more than 20 years and have deep knowledge and insight about the aquatic resources of this region.

There is a fork in the My Thanh River at a position 35 km from the estuary (Figure 1); one branch forms the Vinh Chau Canal and the other the Cai Lon River. The survey was undertaken at the following sites (in km from the estuary): 0, 6, 12, 18, 24, 30, and 36 km along the My Thanh River (seven stations); at two stations along the Vinh Chau Canal at 42 and 48 km from the estuary; at three stations along the Cai Lon River at 42, 48, and 54 km. The survey sites are shown in red (Figure 1).

Sampling data

M. ensis was collected directly by the fishermen with six bag-nets at six stations at 0, 6, 12, 18, 24 and 30 km from the estuary. One bag net was selected at each station to provide the samples and this repeated six times, in February, April, June, August, October, and December.

The samples were kept on ice and measurements made in the laboratory. The parameters measured were the carapace length (CL) and total length (TL), measured with calipers, and body weight (BW) measured with an electronic balance (to within 0.01 g). CL was measured as the shortest distance between the posterior margin of the orbit and the mid-dorsal posterior edge of the carapace. TL was measured from the tip of the rostrum to the tip of the telson, to the nearest 0.1 mm. Sex was determined by shape of petasma and thelycum. The physical environmental criteria were also measured: salinity (ppt), depth (m), and transparency (cm). Besides, 10% of largest shrimp individuals in each sampling time were also selected to check the mature stages (Dineshabu and Manisser, 2008). The Fecundity of mature female was estimated from relationship between ovary weight and CL (Courtney et al., 1989).

Data analysis

Population structure and the catch size were determined with a cumulative normal probability function: A kernel density plot was used to determine the population structure based on CL (mm). It was assumed that CL was normally distribution. The normal density probability function based on two parameters, CL (with mean μ and standard deviation σ) and the density probability (with mean μ and variance σ^2), let's X is variable (CL).

$$P(X = x | \mu, \sigma^2) = f(x) = \frac{1}{\sqrt{2\pi\sigma}} \exp\left[-\frac{(x - \mu)^2}{2\sigma^2}\right]$$

To model CL as continuous data, the random variables must be defined as taking the value of any real number. Because there are infinitely many numbers infinitely close, the probability of any particular value will be zero, the cumulative distribution function can be defined and it has the relationship (Tuan, 2007):

$$pnorm(x, mean, sd) = \int_{-\infty}^x f(x) dx = p(X \leq x | mean, sd)$$

In this study, x is shrimp size (CL), which was caught at the optimal size, the interval values of x and the probability that the shrimp will attain that size (Dalgaard, 2002).

$$F(x) = \int_{-\infty}^x f(x) dx \quad \text{or} \quad 1 - p = \int_{-\infty}^x f(x) dx$$

Variations in CL of *M. ensis* in different months in the My Thanh river evaluated with one-way analysis of variance (ANOVA): Let's CL (mm) of shrimp i^{th} in month j ($j =$ February, April, June, August, October, and December) is x_{ij} , \bar{x}_i is the mean for group i ; \bar{x} is the grand mean CL (average of all observations); and \bar{x}_j is the mean CL (mm) for month j . The observations can be decomposed as $x_{ij} = \bar{x} + (\bar{x}_i - \bar{x}) + (x_{ij} - \bar{x}_j)$, where $(\bar{x}_i - \bar{x})$ is the deviation of the group mean from the grand mean and $(x_{ij} - \bar{x}_j)$ is the deviation of the observation from the group mean, informally corresponding to the model: $x_{ij} = \mu + \alpha_i + \epsilon_{ij}$, $\epsilon_{ij} \sim N(0, \sigma^2)$.

For the six times that *M. ensis* was sampled in the My Thanh river:

- February: $x_{i1} = \mu + \alpha_1 + \epsilon_{i1}$ April: $x_{i2} = \mu + \alpha_2 + \epsilon_{i2}$
- June: $x_{i3} = \mu + \alpha_3 + \epsilon_{i3}$ August: $x_{i4} = \mu + \alpha_4 + \epsilon_{i4}$
- October: $x_{i5} = \mu + \alpha_5 + \epsilon_{i5}$ December: $x_{i6} = \mu + \alpha_6 + \epsilon_{i6}$

The hypothesis that all the groups are the same implies that all α_i values are zero. Note that the error term, ϵ_{ij} , is assumed to be independent and has the same variance, because it is based on the least squares method, to estimate $\hat{\mu}$ and $\hat{\alpha}_i$ with $\sum (x_{ij} - \hat{\mu} - \hat{\alpha}_i)^2$ at minimize.

The total sum of the squares of all sampling during the study:

$$SST = \sum_i \sum_j (x_{ij} - \bar{x})^2$$

The sum of the squares between months:

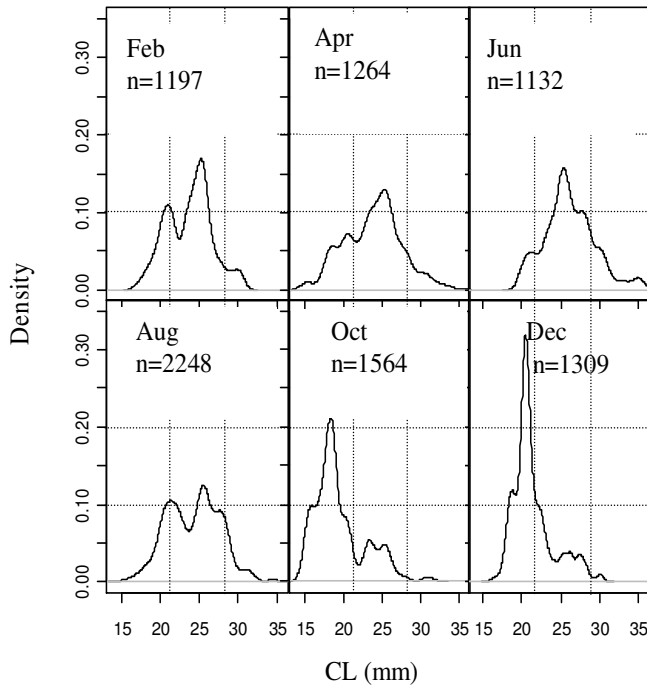

Figure 5. Density plots of *M. ensis* CL (mm) in the My Thanh river for six sampling periods.

$$SSB = \sum_i \sum_j (\bar{x}_i - \bar{x})^2 = \sum_j n_j (\bar{x}_j - \bar{x})^2$$

The sum of the square within months: $SSW =$

$$\sum_i \sum_j (x_{ij} - \bar{x}_j)^2 = \sum_j (n_j - 1) s_j^2$$

SST , SSW , and SSB were calculated from each individual for the six times of sampling, so the mean square within each sampling time (MSW) = $SSW/(N - k)$, and the mean square between the times of sampling (MSB) = $SSB/(k - 1)$, where N is the total shrimp collected, k is the number of sampling times, and $F_{test} = MSB/MSW$. The Tukey's SHD function was also used to test the different CL between months.

Yield (kg/month) of *M. ensis* in the My Thanh river according to month and distance from the estuary: ANOVA was used to test whether the yields of *M. ensis* were affected by time (various months of the year) or localities along the river at different distances from the estuary (km). The Tukey's HSD was also used to test the relationships between the yield and these temporal and spatial factors (month to month, and station to station).

Multiple linear regressions effect on CL of *M. ensis* in the My Thanh river: The factors might affect shrimp size will be tested, such as the time of year (month), the distance along the river relative to the estuary (km), and environmental factors (salinity, transparency and depth). Normally, there is one dependent variable (CL) and multiple independent variables (x_1, x_2, \dots, x_n), and these independent variables can affect the dependent variable by their interaction. If k is the number of independent variables, in this study $k = 6$ (x_1, x_2, \dots, x_6) and $y_1 = f_1(x_1), y_2 = f_2(x_2), \dots$, so there were $2^6 = 64$ estimated models. The optimal model was determined based on Akaike's Information Criterion (AIC), as that with the lowest value for AIC (Tuan, 2007).

For the linear regression equation: $\hat{y}_1 = \hat{\alpha} + \hat{\beta}_1 x_1 + \hat{\beta}_2 x_2 + \dots + \hat{\beta}_k x_k$, with $k + 1$ parameters $\hat{\alpha}, \hat{\beta}_1, \hat{\beta}_2, \dots, \hat{\beta}_k$, and the residual sum of squares

$$RSS = \sum_{i=1}^n (\hat{y}_i - y_i)^2, \text{ where } n \text{ is quantity sampled,}$$

$$AIC = \log\left(\frac{RSS}{n}\right) + \frac{2k}{n}$$

The independent relationships between CL and each environmental parameter, such as salinity, transparency, depth, and the distance of the stations along the river, were also investigated with linear regression and correlation analyses.

Sex ratios of *M. ensis* in the My Thanh river according to month and site: The fluctuations in the sex ratios in the various months of the year and at the various stations along the river were investigated in the study.

RESULTS AND DISCUSSION

Population structure and catch size estimated with a cumulative normal probability function

The range of CL for *M. ensis* was 14.0 to 35.5 mm, with varying frequencies in different months, as shown in Figure 5. The occurrence of *M. ensis* with a $CL < 21.1$ mm was high in October to December (rainy season), whereas shrimp with $CL > 28.3$ mm appeared in February to August (dry to early rainy season).

Proportion of CL of *M. ensis* was shown in Figure 6. The largest cohort class was the optimal size (CL 28.3 to 35.5 mm), and contained approximately 8% of individuals. The probability of fishermen catching shrimp with $CL > 28.3$ mm was 0.16 according to the normal density probability function for *M. ensis* as shown in Figure 7. This size cohort commands higher prices than the other two size classes. Of the remaining shrimp, 82% were ≤ 28.3 mm CL , and command a lower price. In Vietnam, price of *M. ensis* is often according to classical sizes: small (CL 14.0 to 21 mm), medium (> 21.1 to 28.3 mm), large (> 28.3 mm) are priced at US\$2.0 to 2.5, US\$2.6 to 4.0 and US\$4.2 to 5.5 per kg respectively (in 2010).

Results showed that smaller *M. ensis* ($CL < 21.3$ mm) were abundant from August to February, with the highest peak in October to December (rainy season) (Figure 5), whereas the highest peak of natural shrimp recruitment in the mangrove region of the Mekong Delta is July to August (Johnston et al., 2000). The penaeid shrimp is high recruitment peak during spawning in February to March in the coastal waters of the Mekong Delta (Binh and Lin, 1995). According to Johnston et al. (2000) that *M. ensis* is caught throughout the whole year, with an average recruitment density of 0.12 ± 0.02 postlarvae/m³ in the southern Vietnam.

CL was smallest size in October to December ($CL < 21.3$ mm), which may be the main recruitment period for

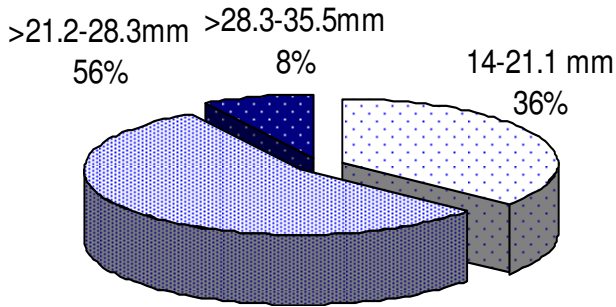

Figure 6. Proportion of *M. ensis* in the three main cohorts of carapace length (mm).

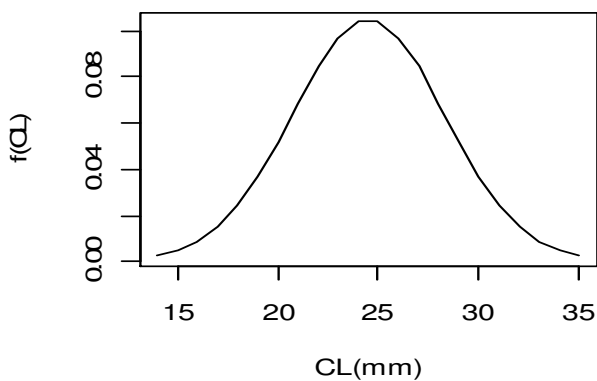

Figure 7. Normal density probability function of *M. ensis* exploited in the My Thanh river with mean CL $\mu = 23.1$ (mm) and standard deviation $\sigma = 3.8$.

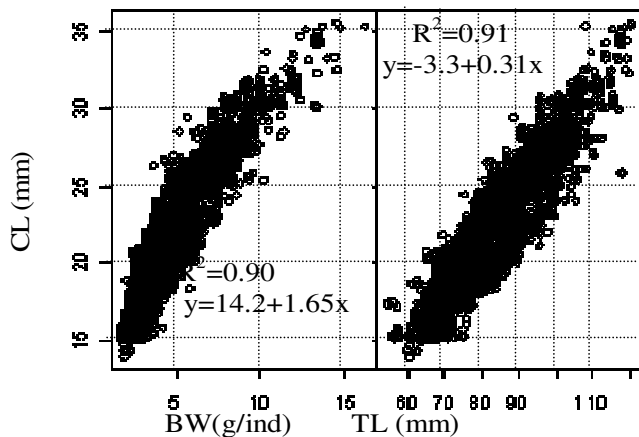

Figure 8. Linear regression between CL (mm) of *M. ensis* and BW (g/individual), CL, and TL (mm) in the My Thanh river.

M. ensis in this region (Figure 5). Another study in Southern Korea showed that the spawning season of *M. joyneri* is June to August, with a peak in July

(Cha et al., 2004). Furthermore, mature shrimp are found all year, with the lowest yield in the winter months, and most abundant in spring and autumn, whereas the immature forms are found most abundantly in February and October (Cheung, 1964). A study in China also found that recruits begin to enter the catches in April to May and grow during June to August, and a smaller autumn recruitment occurs in October (Cheung, 1964).

It can confirm that the recruitment of *M. ensis* occurred many times a year, the frequencies differ across various months. The relationships between *BW*, *TL*, and *CL* in the present study were shown in (Figure 8). A study in the Pearl River of China found that the size of *M. ensis* is 1.0 to 15.7 g/individual (mean 7.5 ± 3.5 g/individual) for females and 1.5 to 11.8 g/individual (5.5 ± 2.5 g/individual) for males (Chu et al., 1995).

Result also found that all of the shrimp sampled were immature stages, which is consistent with study in both Hong Kong (Leung, 1997) and the Pearl River (Chu et al., 1995). This is attributed to low salinity, whereas the mature stage of this species is found at high rates in Australia at salinities of 33 to 34 ppt (Crococ et al., 2001).

Variations in CL of *M. ensis* in different months in the My Thanh river, according to one-way ANOVA

With $n = 8714$ and $k = 6$, the results of ANOVA showed that *SST*, *SSB*, *SSW*, *MSW*, and *MSB* were 129.606, 38.173, 91.433, 10, and 7635, respectively, and $F = 727.12$ ($P < 0.0001$). $\hat{\mu}_1, \hat{\mu}_2, \hat{\mu}_3, \hat{\mu}_4, \hat{\mu}_5,$ and $\hat{\mu}_6$ were 23.71, 0.148, 2.44, 0.52, -4.17, and -2.28, respectively. There were significant differences in the *CL* of *M. ensis* at the six sampling times, result of Tukey's HSD test for each month are shown in Table 1.

The Mekong Delta is a tropical region, the temperature remains stable throughout the year at 29 to 31°C (Department of Natural Resources and Environment of Soc Trang, 2009), whereas the salinity of the My Thanh River fluctuates greatly between the dry and rainy seasons (Figure 4). This area becomes a freshwater region from June to December at 20 to 60 km from the estuary. Cheung (1964) also found that *M. ensis* occurs in both freshwater and brackish water in the Pearl River in China, because it has a wide salinity tolerance (Kungvankij and Chua, 1986). It confirmed that *M. ensis* is widely distributed (Figure 9), and can exist under wide environmental fluctuations, including in salinity, depth, transparency, and proximity to estuarine.

The principal issue for their sustainability is recruitment, which depends on the brood stock, habitats and fishing activities of fishermen.

Yield (kg/month/bag net) of *M. ensis* in the My Thanh River over time and with distance from the estuary

The yields of *M. ensis* were shown in Figure 9. The

Table 1. CL (mm) of *M. ensis* was test by TukeyHSD in various months from sampling in My Thanh river.

Month	Difference	Lower	Upper	p-value
Apr - Feb	0.149	-0.224	0.521	0.866
Jun - Feb	2.443	2.061	2.826	0.000
Aug - Feb	0.528	0.1978	0.859	0.7×10^{-5}
Oct - Feb	-4.174	-4.529	-3.819	0.000
Dec - Feb	-2.283	-2.653	-1.914	0.000
Jun - Apr	2.295	1.917	2.673	0.000
Aug - Apr	0.379	0.055	0.704	0.012
Oct - Apr	-4.323	-4.672	-3.973	0.000
Dec - Apr	-2.432	-2.796	-2.068	0.000
Aug - Jun	-1.915	-2.252	-1.578	0.000
Oct - Jun	-6.618	-6.978	-6.257	0.000
Dec - Jun	-4.727	-5.102	-4.352	0.000
Oct - Aug	-4.702	-5.007	-4.398	0.000
Dec - Aug	-2.812	-3.133	-2.490	0.000
Dec - Oct	1.891	1.545	2.237	0.000

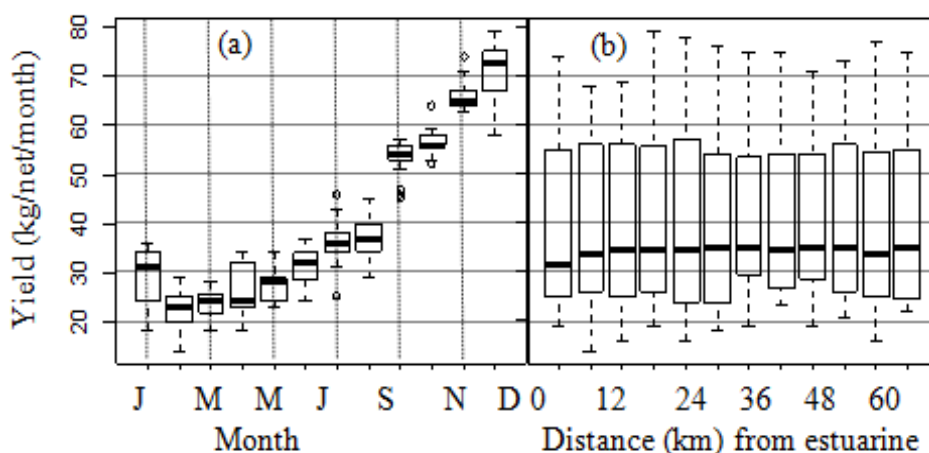
**Figure 9.** Average yield of *M. ensis* exploited by bag net, derived from survey data in the My Thanh river over a period of 12 months (a), and with distance from the estuary (b).

shrimp yield was higher in the rainy season (July to December) than in the dry season (January to June), it was significantly different seasons ($P < 0.001$), whereas the yields were not significantly different among stations ($P > 0.05$), which implies that yields of *M. ensis* caught at the same time (month) at any of these 6 stations were not significantly different ($P > 0.05$).

The highest peak of yield was November and December in the Mekong Delta, whereas a study in Australia found that *M. ensis* is most abundant in spring, from September to November (Crococ et al., 2001). It could be explained that the yield of this species remains constant throughout the year and the peak fishing season is unclear, depending on the physical and chemical environmental characteristics of each location.

The yield of *M. ensis* was higher in rainy months than in

dry months, because the tidal regime in the rainy season fluctuates widely (Figure 10). *M. ensis* migrates more when the tidal regime shows high fluctuations (Garcia, 1985). According to the fishermen, the yield of shrimp was unstable across the days of the month, depending on the lunar cycle, and was often high for about six days per month (14th, 15th, 16th, 29th, 30th and 1st within the month). On these days, the yield of *M. ensis* was 7 to 9 times higher than on other days, because the water levels fluctuated maximally between high and low tides and migration often follows these conditions (Garcia, 1991).

There is conflict in fishing activities and income of fishermen, when the shrimp had attained the optimal size (CL > 28.3 mm) in April to August, it was low yield and low income for fishermen (Figure 8), whereas *M. ensis*

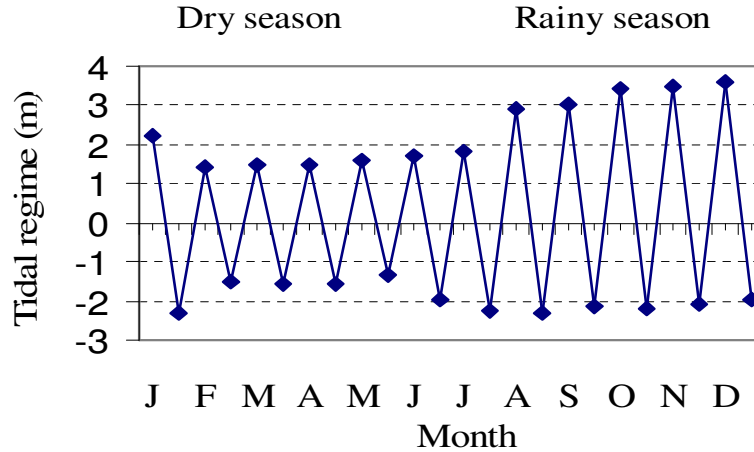

Figure 10. Tidal regime in a coastal region of the Mekong Delta (Southern Hydrographic Center of Vietnam, 2010).

Table 2. Optimal models can be used to predict CL(mm) of shrimp in My Thanh river.

Model	AIC
CL ~ salinity + km + transparency + depth (1)	21,748
CL~ salinity + km + depth	46,499
CL~ salinity + depth	47,013
CL~ Km + depth	48,150

were abundant (November to December), most of them were small and sold low price (Figure 5). Therefore, fishermen must increase their fishing activities as prolong the fishing time, the mesh size of the net is designed smaller than compare with regulations, this problem caused a waste of natural shrimp and affected sustainable development.

The survey results also showed that the yield of *M. ensis* has decreased rapidly in recent years, many reasons have been considered including mangrove clearance, narrow habits, overfishing, and urbanization (Johnston et al., 2000; Hong, 1996), the decline in fisheries resources has implications for millions of coastal families that depend on the fisheries for their food and livelihoods in these developing countries (Ablan, 2006).

Multiple linear regression analysis of factors affecting the CL of *M. ensis* in the My Thanh River

Salinity, depth, transparency, and the various positions along the river have affected to CL of *M. ensis*, when analyzed with the interactive multiple model shown in Table 2. Results found that four of these variables accounted for about 18.5% of the variance in CL ($R^2 = 0.19$), although these variables were significantly different ($P < 0.001$). Equation (1) is considered the optimal model

because its AIC value was lowest for the linear regression analysis of the factors in the My Thanh River:

$$CL = - 5.1 + 0.34 * salinity + 3.8 * transparency + 1.56 * depth + 0.09 * distance \tag{1}$$

However, independent analyses were made of the correlation between CL and each factor (salinity, depth, distance of the sampling site and transparency) as shown in Figure 11. These results confirmed that the CL of *M. ensis* was not strongly affected by these factors and the correlation coefficient R^2 was low between CL and each independent variable.

Sex ratios of *M. ensis* in the My Thanh river in different months and at different sites

The sex ratios of *M. ensis* were shown in Figure 12, female rates were higher than the male rates ($P < 0.05$) at the various positions of the bag nets along the river in August, October, and December (rainy season), but there were no significant differences in these proportions among the stations ($P > 0.05$). The proportions of females and males were equal in February, April, and June (dry season). The proportion of females was higher than that of males (females 60% and males 40%) at various positions on the river between the estuary and

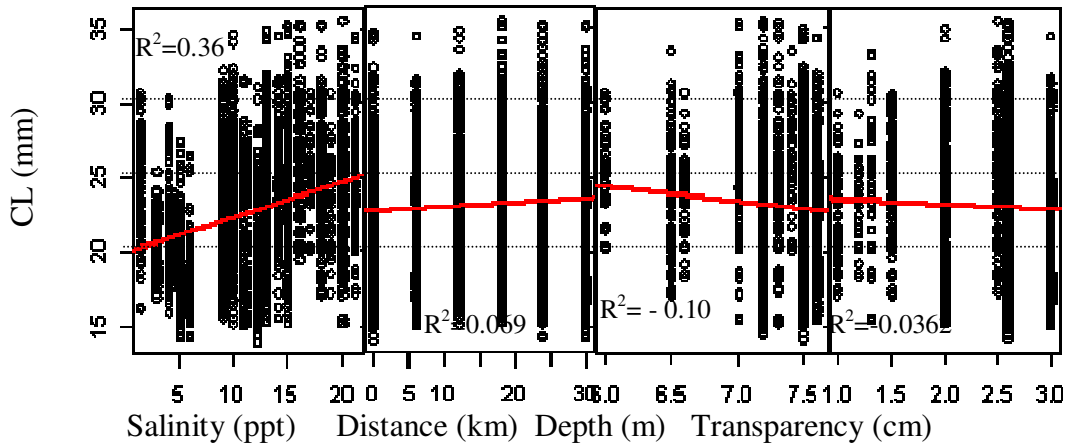

Figure 11. Correlation between CL (mm) of *M. ensis* and salinity (ppt), depth (m), distance from the estuary (km), and transparency (cm).

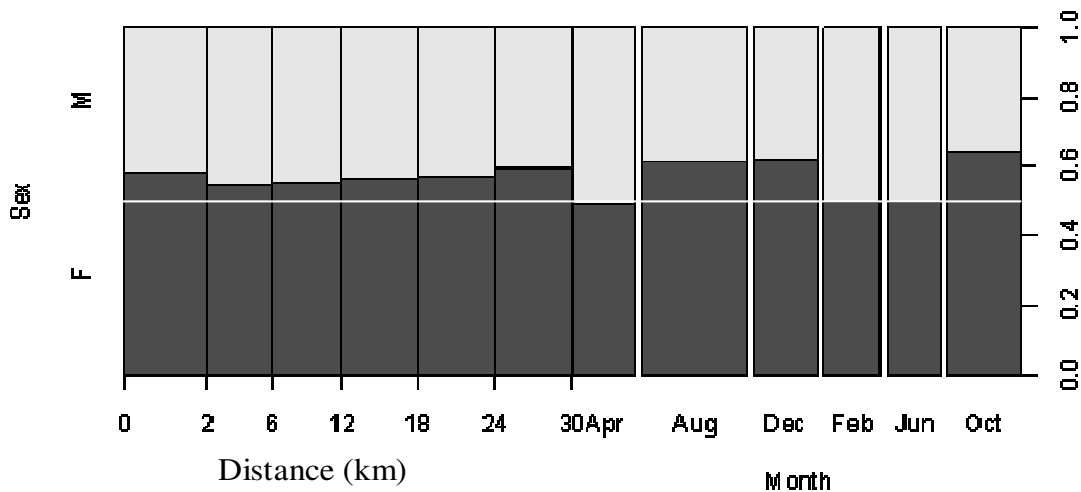

Figure 12. Ratios of female to male of *M. ensis* with distance from the estuary, and for various months of the year.

30 km upstream.

In February and June, the sex ratio was 1:1, whereas in other months, the females constituted 60 to 63% and the males 37 to 40%. However, the sex ratio for males: females are 1:2.3 in the Pearl River, China (Chu et al., 1995).

Conclusion

M. ensis was widely distributed and tolerated high fluctuation of environment, it was caught year around, the yield in rainy was higher than in dry season, CL in dry season was larger than in rainy season, most of shrimp were caught in post larval and sub-adult stages, so it has with low price in market, this problem caused by waste natural resources and effect to sustainable development.

ACKNOWLEDGMENTS

The first author would like to thank the Vietnamese Government for support by scholarship through the Ministry of Education and Training/Vietnam International Education Development: Project 322. Our thanks are extended to Mrs Q. T. T. Binh at the Department of Fisheries Management of Soc Trang Province for her help in various ways during the data collection.

REFERENCES

Ablan MCA (2006). Genetics and the study of fisheries connectivity in Asian developing countries. *J. Fisher. Res.* 78:158-168.
 Binh CT, Lin CW (1995). Shrimp culture in Vietnam. *World Aquaculture.* 26(4):27-33.
 Cha HH, Choi JH, Oh CW (2004). Reproductive biology and growth of the shiba shrimp *Metapenaeus joyneri* (decapoda: penaeidae) on the

- Western coast of Korea. *J. Crustacean Biol.* 24(1):93-100.
- Cheung TS (1964). Contributions to the Knowledge of the Life History of *Metapenaeus ensis* and Other Economic Species of Penaeid Prawns in Hong Kong. *J. Appl. Ecol.* 1(2):369-386.
- Chu KH, So BSH (1987). Changes in salinity tolerance during larvae development of the shrimp *Metapenaeus ensis* (De Haan, 1844). *J. Asian Mar. Biol.* 4:41-48.
- Chu KH, Chen QC, Huang LM, Wong CK (1995). Morphometric analysis of commercially important penaeid shrimps from the Zhujiang estuary, China. *Fisher. Res.* 23:83-93.
- Courtney AJ, Dredge MCL, Masel JM (1989). Productive biology and spawning periodicity of endeavour shrimp *Metapenaeus endeavour* (Schmitt, 1029) and *M. ensis* (De Hann, 1850) from central Queensland. *Austr. Asian. Fisher. Sci.* 3:133-147.
- Crococ PJ, Park IC, Die DJ, Warburton K, Manson F (2001). Productive dynamics of endeavour prawns, *Metapenaeus endeavouri* and *M. ensis*, in Albotross bay, Gulf of Carpentaria. *Austr. J. Mar. Biol.* 138:63-75.
- Dalgaard P (2002). *Introductory statistics with R.* Springer science. P. 267.
- Department of natural resources and environment of Soc Trang province (2009). Annual report of natural resource and environment (in Vietnamese)
- Dineshbabu AP, Manissery JK (2008). Reproductive biology of ridgeback shrimp *Solenocera choprai* (Decapoda, Penaeoidea, Solenoceridae) off Mangalore coast, South India. *J. Fisher. Sci.* 74:796-803.
- FAO (2002). *The State of World Fisheries and Aquaculture.* Food and Agriculture Organization of the United Nations, Rome.
- Garcia S (1985). Reproduction, stock assessment models and population parameters in exploited penaeid shrimp populations. In: Rothlisberg PC, Hill BJ and Staples DJ (Eds.), *Second Australian National Prawn Seminar, Cleveland, Queensland, Australia.* pp. 139-158.
- Garcia S (1991). Tropical penaeid prawns. In Gulland JA (Editor), *Fish population dynamic,* published by John Wiley & Sons. Ltd, P. 422.
- Holthuis LB (1980). Shrimps and prawns of the world, An Annotated Catalogue of Species of Interest to Fisheries. *FAO Species Catalogue,* P. 1.
- Hong PN (1996). Mangrove destruction of shrimp rearing in Minh Hai, Vietnam: its damage to natural resources and the environment. *SEAFDEC Asian Aquac.* 18(3):6-11.
- Hung NN (2009). Naturally characteristic - procedure to make exchange fertile of soil in the Mekong delta published by agricultural housing. P. 471.
- Johnston D, Trong NV, Tuan TT, Xuan TT (2000). Shrimp seed recruitment in mixed shrimp and mangrove forestry farms in Ca Mau Province, Southern Vietnam. *J. Aquac.* 184:89-104.
- Kungvankij P, Chua TE (1986). *Shrimp culture: Pond design, operation and management,* FAO, P. 65.
- Leung SF (1997). The population dynamics of *Metapenaeus ensis* (Crustacea: Decapoda: Penaeidae) in a traditional tidal shrimp pond at the Mai Po Marshes Nature Reserve, Hong Kong. *J. Zool.* 242(1):77-96.
- Liao IC, Chao NH (1983). Development of prawn culture and its related studies. In: Rogers GL, Day R and Lim A (Eds.). *The first national conference on warm water aquaculture – crustacean.* Brigham young University Hawaii campus, USA, pp. 127-142.
- Ministry of Fisheries (1996). *Vietnam fisheries aquatic resources,* published by agricultural housing of Vietnam, P. 615.
- Southern hydrographic Center of Vietnam (2010). *Annual report the status of tidal regime in coastal region of Mekong delta Statistical Book of Soc Trang Province (2009).* Publish by general Statistic of Vietnam.
- Tuan NV (2007). *Data analysis and graph by using R.* scientific and technical publisher of Vietnam (in Vietnamese). P. 338.