

Full Length Research Paper

Application of the erbium-doped fiber amplifier (EDFA) in wavelength division multiplexing (WDM) transmission systems

G. Ivanovs, V. Bobrovs, S. Olonkins, A. Alsevskā, L. Gegere, R. Parts, P. Gavars and G. Lauks

Institute of Telecommunications, Riga Technical University, Azenes Str. 12, Rīga, LV-1048, Latvia.

Received 7 November, 2013; Accepted 19 February, 2014

In the work, characteristics of the erbium-doped fiber amplifier (EDFA) are investigated. The amplification and noise figure dependences on different EDFA parameters in a 2.5 Gbit/s one-channel WDM transmission system are simulated and measured. Additionally, simulation of a four-channel 2.5 Gbit/s WDM system containing in-line amplifiers of the type was done in order to investigate the EDFA performance in multichannel systems. Almost identical results obtained for both the simulation model and the experimental system are indicative of high accuracy of the simulation. It is shown that the EDFA amplification depends on such parameters as the signal power, wavelength, EDF length, and configuration of the pump laser.

Key words: Wavelength division multiplexing (WDM), erbium-doped fiber amplifier (EDFA).

INTRODUCTION

The capacity of fiber optical communication systems has undergone enormous growth during the last few years in response to huge capacity demand for data transmission (Cisco Systems, 2010). With the available WDM components, commercial systems transport more than 100 channels over a single fiber (Bobrovs et al., 2009). Hence, the installed systems of the type can be upgraded many times without adding a new fiber, which makes it possible to build inexpensive WDM systems with much greater capacity (Azadeh, 2009). Increasing the number of channels in such systems will eventually result in the usage of optical signal demultiplexing components with greater values of optical attenuation. Additionally to this, when transmitted over long distances, the optical signal is highly attenuated, and, therefore, to restore the optical power budget it is necessary to implement optical signal

amplification. At the choice of signal amplification method for the wavelength division multiplexing (WDM) systems the preference is given to the class of erbium-doped fiber amplifiers (EDFAs). These amplifiers are low-noise, almost insensitive to polarization of the signal and can be relatively simply realized (Dutta et al., 2003). Besides providing gain at 1550 nm, in the low-loss window of a silica fiber such amplifier allows achieving such gain in a band wider than 4000 GHz. To ensure the required level of amplification over the frequency band used for transmission it is highly important to choose the optimal configuration of the EDFAs, as the flatness and the level of the obtained amplification, and the amount of EDFA produced noise are highly dependent on each of the many parameters of the amplifier. In this article the authors investigate the behavior of EDFAs depending on

*Corresponding author. E-mail: anita.alsevska@rtu.lv. Tel: +371 26757946.

Author(s) agree that this article remain permanently open access under the terms of the [Creative Commons Attribution License 4.0 International License](https://creativecommons.org/licenses/by/4.0/)

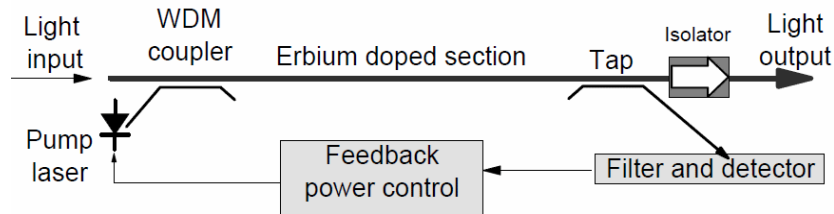

Figure 1. Scheme of the erbium-doped fiber amplifier (Dutta et al., 2003).

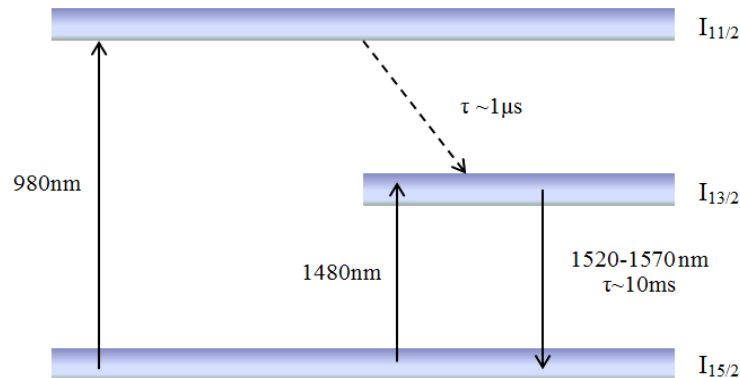

Figure 2. Schematic diagram of erbium ion energy levels and the spontaneous lifetimes of excited levels.

such amplifier parameters as input optical power, power and wavelength of the pumping radiation, length of the EDF and the achieved level of erbium population inversion.

MAIN COMPONENTS OF ERBIUM-DOPED FIBER AMPLIFIER

The amplifier under consideration consists of a fiber having a silica glass host core doped with active Er ions as the gain medium (Becker et al., 1999). The erbium-doped fiber is usually pumped by semiconductor lasers at 980 nm or 1480 nm. The signal is amplified while propagating along a short span of such a fiber (Agrawal, 2002). A simplified scheme of the EDFA is displayed in Figure 1.

In the scheme, the amplifier is pumped by a semiconductor laser, which is complemented with a wavelength selective coupler (also known as the WDM coupler) which combines the pump laser light with the signal light. The pump light propagates either in the same direction as the signal (co-propagation) or in the opposite direction (counter-propagation). Optical isolators are used to prevent oscillations and excessive noise due to unwanted reflections (Mukherjee, 2006).

The main condition that should be fulfilled to ensure the optical power transfer to the signal is that the

erbium atoms are to be in the excited state. The excitation is performed by a powerful pumping laser with a corresponding radiation wavelength of 980 nm or 1480 nm. The pump laser diode, as shown in Figure 1, generates a high-power beam of light at such a wavelength that the erbium ions absorb it and reach the excited state. When the photons belonging to the signal meet the excited erbium atoms, these atoms give up a portion of their energy to the signal and return to a lower-energy state (Figure 2). Erbium gives up its energy in the form of additional photons which have exactly the same phase and direction as the signal being amplified. So the signal is amplified along its direction of travel only. The pumping laser power is usually controlled via feedback (Trifonovs et al., 2011).

The gain spectrum of EDFAs is determined by the molecular structure of the doped fiber, and is strictly wavelength-dependent. The main disadvantage of EDFAs is that even though their gain spectrum bandwidth can reach 4000 GHz, it is highly wavelength dependent, and obtaining relatively flat gain spectrum over a wide wavelength band can become complicated. This problem can be solved by supplementing the EDFA with another type of amplifier, that is, distributed Raman amplifier, the gain spectrum of which can be varied in a way to obtain flat overall gain over the desired wavelength band. Such solution will also increase the achievable level of amplification, but one must always

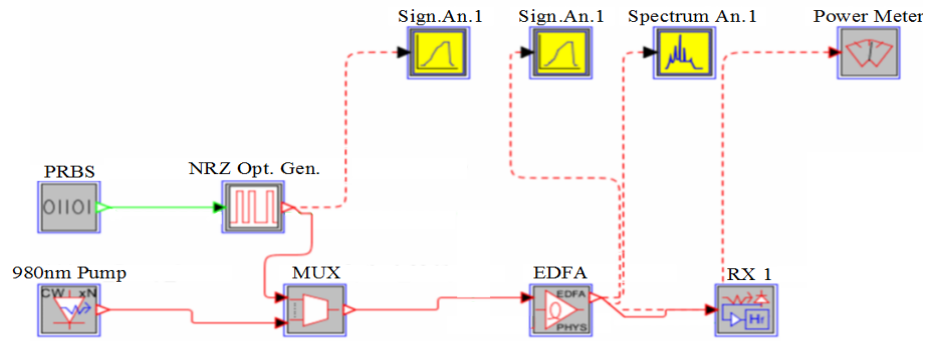

Figure 3. Simplified optical network for studying EDFA parameters.

take into account the accumulating impact of fiber nonlinearity (Bobrovs et al., 2013).

Due to the wavelength dependency of the gain, EDFAs can ensure amplification of individual channels and, therefore, no cross-gain saturation will occur during the process of amplification. Due to a relatively long spontaneous carrier lifetime in silica fibers, this allows achieving high gain for a weak signal with low noise figure, which represents the difference in signal-noise ratio at the input and output of the device under consideration (Bobrovs et al., 2013).

REALIZATION OF EDFA AND EXPERIMENTAL MEASUREMENT SCHEME

Experimental results for investigation of EDFA performance dependence on the parameters of the amplifier were obtained by introducing a simulation model of a single channel optical transmission system, and comparing the obtained results with results obtained in a real-life experiment. Afterwards a simulation model of a 4 channel WDM transmission system was introduced to assess the performance of the EDFA, when it is used as an in-line optical amplifier in a multichannel WDM system.

Simulation of the EDFA amplifier was done with the help of RSoft Design Group OptSim™ software. This software offers two simulation modes: The sample mode and the block mode. The latter was used since it allows observing and studying the EDFA intrinsic processes: The pump power and amplification propagation as well as appearance of ASE (amplified spontaneous emission) noise and its evolution along the fiber (OptSim User Guide, 2008).

For studying the EDFA parameters and their impact on the total signal amplification and the ASE noise increase, a one-channel optical link scheme was developed. As shown in Figure 3, the scheme contains three main sections: transmitter, amplifier, and receiver sections.

The transmitter section consists of a binary data source and a non-return-to-zero (NRZ) on-off keying optical

signal source. The data source generates 2.5 Gbit/s data flow. The NRZ version was chosen because it is the most popular code method used in optical transmission systems and due to its comparatively simple realization (Bobrovs et al., 2011). The signal wavelength $\lambda = 1535$ nm corresponds to the C optical band (Mukherjee, 2006). The power of optical signal was set to -30 dBm (a typical value for a weak signal to reach the amplifier).

The amplifier section consists of a physical model of the EDFA which, in turn, includes an optical multiplexer and a 980 nm co-propagating continuous wave pumping laser. To simplify the simulation process and to focus on the EDFA performance, transmission fiber was not included in this simulation scheme. Other EDFA parameters: the erbium-doped fiber (EDF) length l was 14 m, and the pumping laser power was $P = 40$ mW.

The receiver section consists of a PIN photodiode, a preamplifier and a Bessel's filter, grouped together in one receiver (Bobrovs et al., 2010). The measuring elements were placed before and after the amplifier in order to detect changes of parameters of the amplified signal that occur in the EDF (Udalcovs et al., 2011).

The simulation results are compared with those of experimental measurements in an EDFA scheme (also consisting of transmitter, amplifier and receiver sections (the latter is represented by an optical spectrum analyser) as shown in Figure 4.

For realization of the amplifier, an HWT-FIB-EDF-741 erbium doped fiber (intended for the C optical band) was used. The scheme parameters were the same as in the simulation. A 1480 nm co-propagating laser with the maximum output power of 14 dBm was taken so that the erbium ions achieve the excited state. A 0 to 30 dB signal attenuator was employed in order to acquire a low input signal power at the input of the amplifier. The signal power at the input of the amplifier was sufficient to study EDFA parameters and to provide a good erbium population inversion in a 4 m EDF.

During the first simulation, the EDFA ability to amplify optical signal at different power levels was investigated. The amplified signal power at the EDFA input was increased from -40 to 0 dBm with 4 dB steps. The

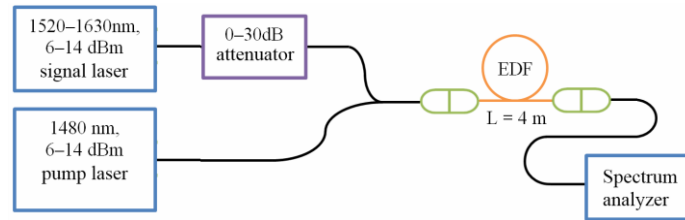

Figure 4. Experimental scheme of EDFA measurements.

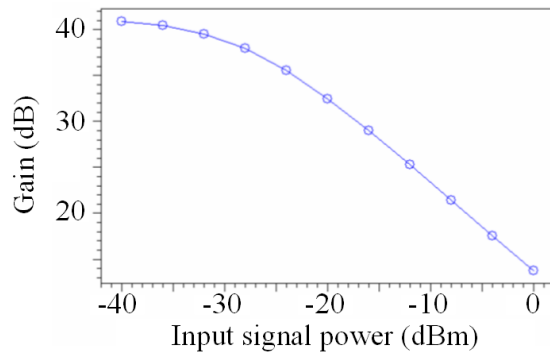

Figure 5. Amplification vs. the input signal power.

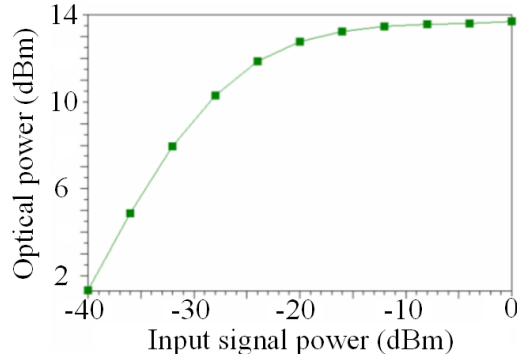

Figure 6. Output signal power vs. the input signal power.

obtained dependences are shown in Figures 5 and 6.

In Figure 5 amplification is seen to decrease, which is due to insufficient erbium inversion, but as can be seen in Figure 6 the optical signal power at the output of the amplifier has increased. The character of this increase clearly indicates that when the input signal power is larger than -20 dBm the EDFA with the previously described configuration is operating close to its saturation mode.

The EDFA graphs with different input signal levels (-40, -20 and 0 dBm) were created to show the intrinsic process in detail (Figure 7). In this figure it could be seen that with increasing input signal power level at the

pumping laser power and EDF length being constant, the total Erbium inversion is decreasing.

The co- and counter-propagating ASE noise figures (NFs) are decreasing almost proportionally to the increase in the input signal power: a more powerful signal uses more excited erbium to gain amplification, while less excited erbium remains for the amplification of spontaneous emission (Figure 8).

Although experimental measurements and the performed simulation have shown similar results, the experimental equipment setup and the simulation setup were slightly different. Therefore, a second simulation was needed the parameters of which would be based on the experimental EDFA amplifier model created at the Fiber Optics Transmission Systems Laboratory.

As can be seen in Figure 9, the highest level of amplification achieved with the experimental EDFA scheme is only 5.7 dB, while the simulation gives 6.1 dB. This can be explained by low power of the 1480 nm pump laser and short EDF fiber span (4 m).

Figure 10 shows the optical power spectra obtained in the second simulation and in the experimental scheme. It can be seen that the pump power is almost constant when the input signal power is increased, whereas the total ASE noise power decreases (red line). The ASE peak at 1530 nm in Figure 10b and d is not so explicit as in Figure 10a and c. This means that the excited erbium that was wasted on the ASE amplification now starts to amplify a stronger input signal (Figure 10a and c).

The EDFA produced amplification is more efficient for weaker signals than for stronger ones: In the former case the signal gain can reach ≥ 40 dB. However, in this case EDFA will produce a large amount of ASE noise - up to 30 dB more than in the case where a 0 dBm optical signal was amplified. In the case of only one in-line amplifier no severe degradation of system performance would be expected. A weak signal will be amplified and, having a relatively low noise level, will reach the receiver maintaining the required quality of the signal. However, if there are many in-line amplifiers, extra care should be taken of the signal level at their input. If it is less than -20 dBm, EDFA will add additional ASE noise of relatively high power which will spread further along with the signal. A next EDFA will amplify ASE noise in the signal spectrum together with the signal, also creating an additional portion of ASE. This will cause severe signal-

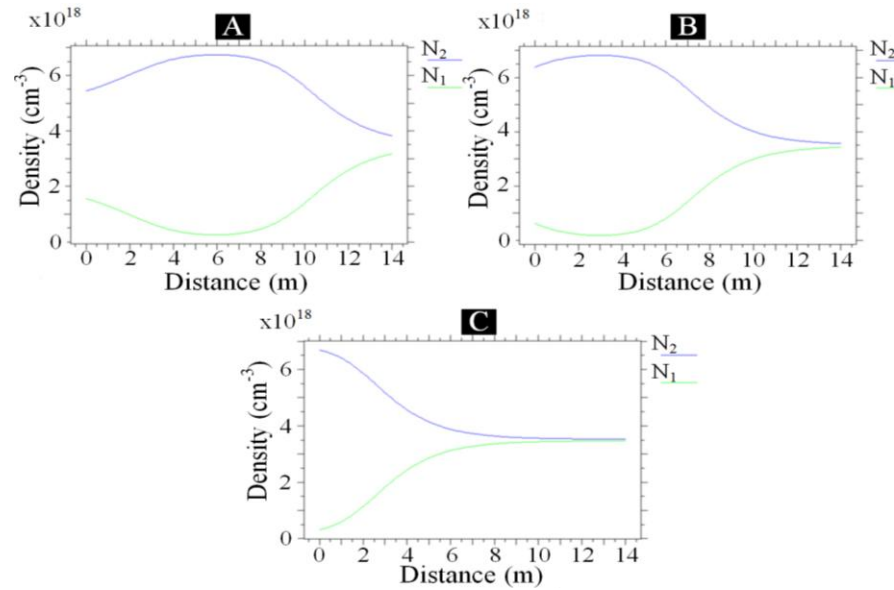

Figure 7. Excited erbium state densities at different input signal levels: -40 dBm (a), -20 dBm (b) and 0 dBm (c). N₂ – excited state, N₁ – ground state.

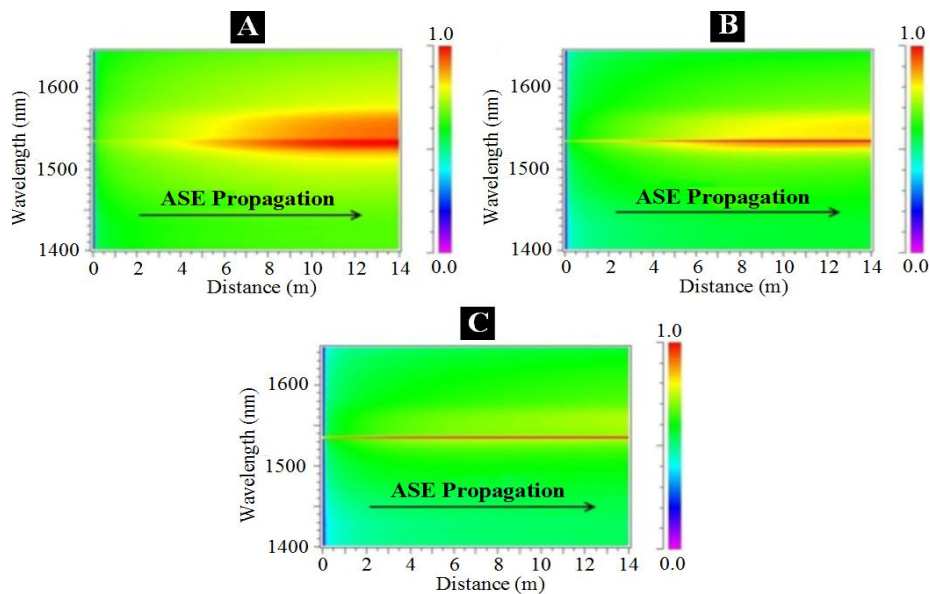

Figure 8. Co-propagating ASE generation at different input signal levels: -40 dBm (a), -20 dBm (b) and 0 dBm (c).

to-noise ratio degradation.

In the second experiment, the dependences of amplification and noise on the EDF length (varied from 5 to 30 m with a 5 m step) were investigated. Other parameters were kept constant. The obtained results are shown in Figure 10a and b.

The maximum amplification with chosen parameters was achieved for the 15 m long EDF. In turn, the noise

figure (the relation of signal-to-noise ratio before and after amplification) increased with the EDF length.

To analyze the dependences shown in Figure 11, EDFA internal erbium density state graphs were obtained (Figure 12). At the EDF length of 5m (Figure 12a) all erbium is in excited state. The signal obtains only half of the achievable gain in such a short fiber span; in turn, the ASE noise level is quite low. This shows that the EDFA is

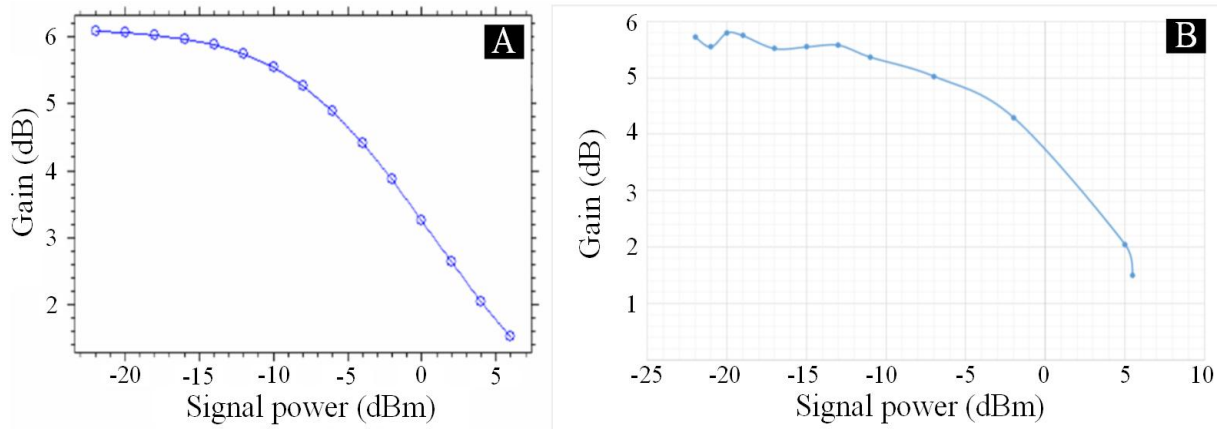

Figure 9. EDFA amplification vs. the input signal power: simulation (a), and measurements (b).

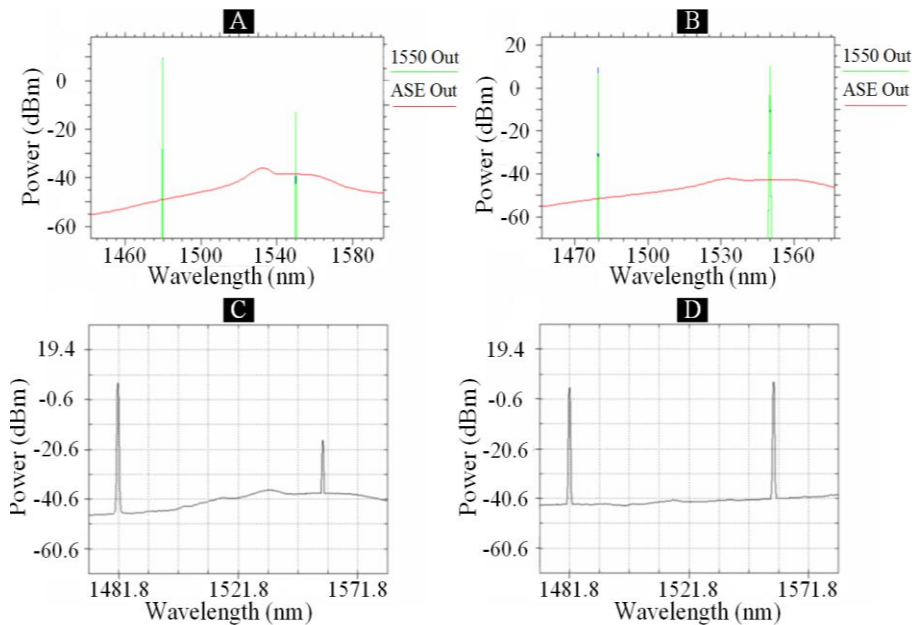

Figure 10. Power spectra at the EDFA output. Simulation – input signal power -22 dBm (a), 6 dBm (b), measurement – input signal power -21.66 dBm (c), 6 dBm (d).

operating in the saturation mode, with almost 100% inversion and the amplification being homogeneous throughout the EDF.

When the length of the EDF was increased to 20 m (Figure 12b) at the 15th meter of the EDF signal amplification achieves its maximum, while the amount of excited erbium ions is approaching that of the base state erbium – from this point on the EDFA does not amplify the signal. Counter-propagating ASE also leads to the inversion decrease at the beginning (first 0-5 m) of the EDF fiber. In the case of a 30 m long EDF (Figure 12c) starting from 15 m and to the end of the fiber, erbium inversion was lower than 50% and signal absorption took

place. In this case the EDF absorbs the signal together with ASE noise.

During the third simulation, different pumping laser configurations were analyzed. The optical power, direction and wavelength of the pump were changed, while other simulation parameters were kept constant. Aggregated information is placed in Table 1. To provide the same amplification, a 1480 nm laser requires longer erbium-doped fiber than a 980 nm one. In the case of 980 nm laser, exciting erbium to a higher energy state requires less energy than in the case of 1480 nm laser at the same laser power, so the use of 980 nm wavelength will ensure a higher level of amplification. At the same

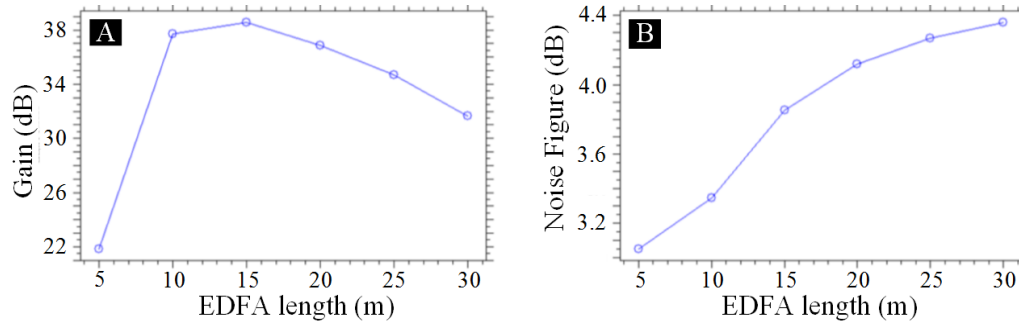

Figure 11. Amplification vs. EDFA length (a), noise figure vs. EDFA length (b).

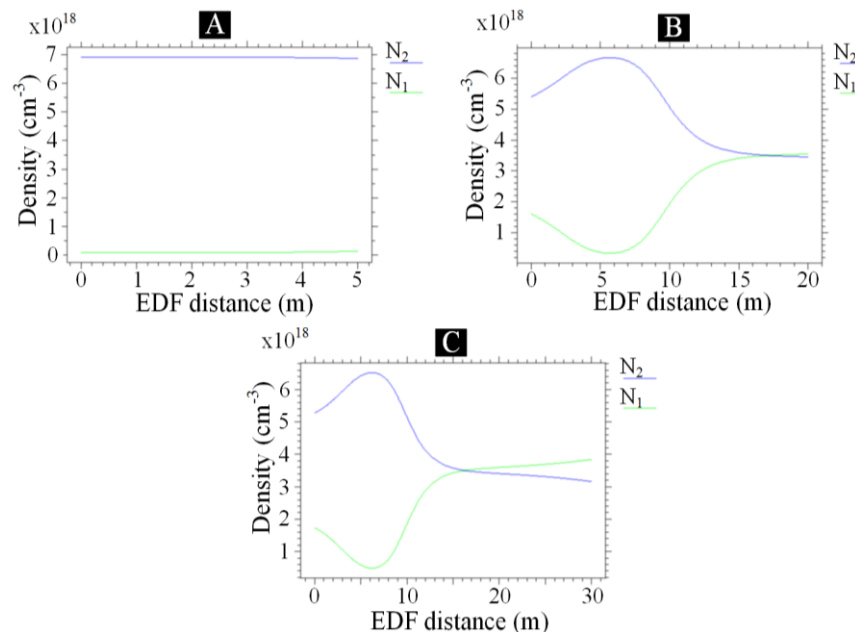

Figure 12. Densities of erbium ion states. EDF length: 5 m (a), 20 m (b) and 30 m (c). N_2 – excited state, N_1 – ground state.

time, using 1480 nm lasers a higher laser power can be applied and even greater output signal level can be achieved. Combined laser pumping, as was expected, gave the largest signal amplification since it provided larger erbium inversion along the erbium-doped fiber length.

The lowest NF was achieved in the case of 980 nm copropagation laser. The highest NF was observed in the case of 1480 nm counter-propagating pumping radiation. Combined pumping showed the best results because it provides high erbium inversion along EDF fiber, and, therefore, the highest gain of all observed pumping configurations and a good noise ratio. The 1480 nm laser allowed achieving a high level of amplification, however produced more noise. Therefore, in a two-laser setup the 1480 nm laser is better to connect in the counter-

propagating direction.

REALIZATION OF A 2.5 GBIT/S WDM SYSTEM WITH IN-LINE EDFA

The WDM transmission system under attention was composed of four 2.5 Gbit/s WDM channels with 50 GHz channel spacing. The line length was 400 km. The impact of dispersion was compensated with the help of a dispersion compensating fiber (DCF). The simplified (does not include all the measurement components) simulation scheme of the 4 channel DWDM transmission system under attention is displayed in Figure 13. Each channel has its own corresponding transmitter and receiver. In the transmitter block the logical signal was

Table 1. Simulation results for -30 dBm 1535 nm signal at the input of EDFA.

Pumping laser	Laser power, mW	Output signal, dBm	Co-prop. ASE, dBm	Counter-prop. ASE, dBm	Co-prop. ASE at 1535 nm dBm	Noise figure, dB
Co-prop. 980 nm laser	10	-0.65	-3	2	-15	3.779
	40	9.1	6	10	-6	3.776
	80	12.7	10	13	-2	3.733
Counter-prop 980 nm laser	10	-0.65	-2	2.5	-10	8.9
	40	9.4	9.4	7	-4	6.2
	80	13	12	11	0	5.6
Co-prop. 1480 nm laser	10	-7.2	0	4	-18	6.79
	40	6.8	9	11	-5	6.72
	80	11	12	15	-1	6.57
Counter-prop 1480 nm laser	10	-7.3	4	0	-12	13.5
	40	6.9	11	10	-2	9.1
	80	11.1	14	12.5	1	8.3
Co-prop. 980 nm and Counter-prop 1480 nm	10	1.68	5	7	-11	5.235
	40	11.1	11	15	-2	5.300
	80	14.7	14.5	18	2	5.205
Co-prop. 1480 nm and Counter-prop 1480 nm laser	10	1.74	7	5	-8	7.57
	40	11.2	14	12.5	0	7.24
	80	14.9	15.5	15	4	7.06

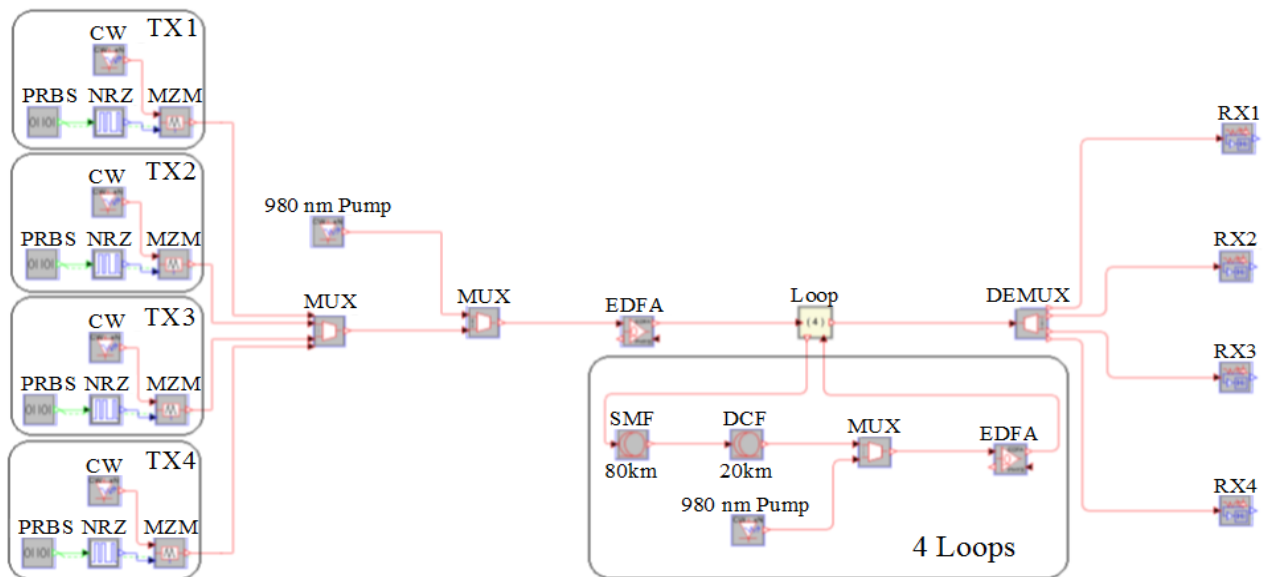

Figure 13. A simplified simulation model of the 400km 4-channel WDM system with EDFA amplifiers.

sent to the electrical signal generator, that produced the NRZ coded electrical signal to be sent to the input of a Mach-Zehnder modulator, which modulates the output light of a continuous wave (CW) laser. Each laser is

operating at its own wavelength: 1555.7, 1555.3, 1554.9 and 1554.5 nm. At the output of modulator a ready for transmission optical signal is produced.

The four generated optical signals are combined into

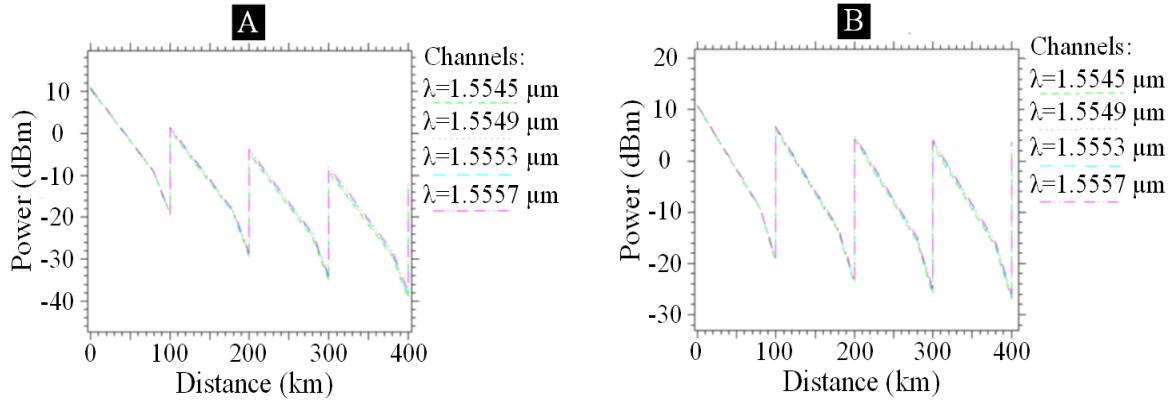

Figure 14. WDM channel optical power changes in the transmission process. EDFA P=40 mw (a), EDFA P=120 mw (b).

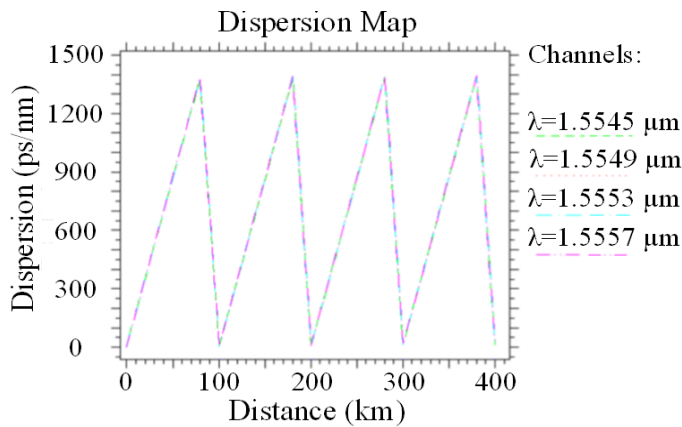

Figure 15. Channel chromatic dispersion changes in transmission process.

one via a WDM multiplexer which transmits signals of only definite wavelengths and filters out the laser-produced noise. Combined signals with the optical power level around -6.5 dBm are sent to a 200 mW optical power EDF amplifier, where a 20 dB optical signal gain is obtained. This was required to reduce ASE noise that occurs in the amplification process. Then the amplified signal propagates over 80 km of a single-mode optical fiber (SMF).

A 20 km long dispersion compensating fiber was placed after 80 km of the standard SMF to compensate the cumulated dispersion. Although the usage of DCF has negative impact on the optical power budget of the transmission system under attention, the negative dispersion of such specific fibers compensates the cumulated positive dispersion of the standard SMF. After 100 km (80 km + 20 km) of the optical line, signals are amplified by an EDFA with variable power and constant other parameters. A 980 nm co-propagating pump laser and a 25 m long erbium-doped fiber were used in this simulation. In the scheme, the SMF-DCF-EDFA section is

repeated four times.

After processing through the respective four loops the signal is demultiplexed. The ASE noise that has accumulated while the signal was propagating through the four sections is filtered out outside the spectra of the transmitted signals. Each optical signal is directed to the corresponding receiver and converted into electrical current. Different measuring elements are located throughout the WDM system for monitoring of noise and signal power levels and the signal quality, as well as tracking all changes in the optical line.

By increasing simultaneously the laser power of all four EDFAs from 40mW to 120 mW with steps of 20 mW, signal amplification and noise figures were obtained for each EDFA amplifier in the scheme. It was found that both signal and noise amplification had increased; however, the power level of signal gradually decreased, while the noise power increased with each following stage of amplification. In all simulation cases, even at the maximum EDFA pumping power, the power levels of all 4 WDM channels decreased while propagating along the system (Figure 14a and b). This evidences that ASE noise gradually took over most of EDF provided erbium population inversion and left little of it for signal amplification. Therefore, the experiment has proved the necessity of filtering ASE after each amplification stage. Figure 14a and b show the evolution of signal power along a 400 km transmission line. The SMF and DCF optical attenuation was 0.25 and 0.5 dB/km, respectively. The EDFA provided gain was almost identical for all four channels of the transmitted signal, but at the end of line a slight variation in the power level between the channels was observed.

The evolution of the cumulated chromatic dispersion along the transmission line under test is shown in Figure 15. It can be seen that the EDFA had no strong influence on the signal dispersion, which increased up to 1380 ps/nm while the signal was propagating through 80 km SMF spans, and then decreased rapidly at signal's propagation through the DCF. Only 15 ps/nm of the

Table 2. Optical power and noise figure values of demultiplexed signals.

Channel number / wavelength	EDFA laser power P				
	P = 40 mW	P = 60 mW	P = 80 mW	P = 100 mW	P = 120 mW
Demultiplexed signal optical power (dBm)					
Channel / 1555.7 nm	-14.71	-7.17	-3.51	-1.16	0.53
Channel / 1555.3 nm	-15.36	-7.75	-4.05	-1.68	0.03
Channel / 1554.9 nm	-15.86	-8.18	-4.45	-2.06	-0.33
Channel / 1554.5 nm	-16.44	-8.71	-4.95	-2.55	-0.81
Noise figure value of demultiplexed signal (dB)					
Channel 1/ 1555.7 nm	19.74	12.19	8.53	6.19	4.49
Channel 2/ 1555.3 nm	21.09	13.95	10.54	8.38	6.83
Channel 3 / 1554.9 nm	21.07	13.4	9.67	7.29	5.56
Channel 4 / 1554.5 nm	21.46	13.73	9.97	7.57	5.83

cumulated dispersion was observed at the input of the receiver block.

Table 2 shows that together with the pumping power of the EDFA also the power of amplified channels increases. It is highly important that the power levels equalize, which is caused by the amplifier saturation effect. This shows that at higher pumping levels a smoother gain spectrum can be obtained for a definite frequency band.

Higher power levels also result in an NF decrease, since the amplifiers were operating in the saturation mode, where most of the population inversion was used for signal amplification; hence, only a minor portion was spent on generation and amplification of ASE.

From Table 2 it also can be seen that difference in amplification over the bandwidth of 1.2 nm used for transmission has reached 1.34 dB. Our previous studies have shown that supplementing the EDFA with a distributed Raman amplifier, the gain spectrum of which can be changed by varying the parameters of the pump, can severely reduce the overall gain difference (Bobrovs et al., 2013).

The obtained experimental results show that at least the -20 dBm power of the transmitted signal is required at the input of each amplifier in order to ensure the appropriate performance of a WDM system with several EDFA in-line amplifiers. It was found that for a lower signal power the generated ASE noise is greater at the output of the amplifier. To ensure a higher optical power level of the transmitted signal at the input of the in-line amplifiers the use of optical power boosters at the output of the transmitter is a good solution.

CONCLUSIONS

The results of investigation into the EDFA operating parameters and their impact on the resulting gain and noise allow for the following conclusions:

1. With increasing signal power at the EDFA input the gain and the generated ASE noise are decreasing. According to our observations, the most effective way to decrease the ASE noise generated by the amplifier is to ensure the required signal power at its input.
2. For any pump power of the EDFA there exists an optimal length of the erbium-doped fiber. In the cases when it is too short the whole potential of the EDFA amplifier cannot be fully realized and a portion of the pumping radiation will be wasted. In the cases when the EDF length exceeds the optimal value, the required level of population inversion cannot be achieved over the whole EDF, which may cause absorption of the amplified signal.
3. The use of a 980 nm co-propagating pumping radiation is the most efficient solution for single pump EDFAs. In comparison with the 1480 nm pump, the former can ensure a higher level of amplification along with less generated ASE noise at the same level of pump power.
4. In multichannel WDM systems with EDFAs the level of amplification is not equal for all channels of the amplified signal. The obtained results have shown that it is possible to reduce this difference by providing an appropriate configuration of the amplifier at which a proper level of population inversion is achieved. This will lead to changes in the shape of the EDFA gain spectrum, and at a definite inversion level of erbium ions the least achievable difference can be obtained.
5. In the system with multiple amplification stages the level of ASE noise generated by EDFA gradually accumulates along the transmission line. Each subsequent EDFA not only generates a new portion of the ASE noise, but also amplifies the incoming ASE produced by the previous EDFA. Some its portion can be filtered out; however, the ASE spectral components whose wavelengths correspond to those of the amplified channels cannot be removed by optical filters. The proposed solution of this problem is to ensure high enough signal power at the input of the amplifier in order

to keep the total ASE level low and to place optical filters after each stage of amplification.

ACKNOWLEDGMENT

This work was supported by the European Regional Development Fund in Latvia within the project Nr. 2010/0270/2DP/2.1.1.1.0/10/APIA/VIAA/002.

Conflict of Interests

The author(s) have not declared any conflict of interests.

REFERENCES

- Agrawal GP (2002). Fiber-optic communication systems. New Jersey: John Wiley and Sons, P. 567. <http://dx.doi.org/10.1002/0471221147>
- Azadeh M (2009). Fiber Optics Engineering. New York: Springer, 374:3
- Becker PC, Olsson NA, Simpson JR (1999). Erbium-Doped Fiber Amplifiers. Academic Press, P. 481. PMID:PMC2726259
- Bobrovs V, Jelinskis J, Ivanovs G, Lauks G (2009). Research of traffic management in FTTx optical communication systems. Latvian J. Phys. Technical Sci. 2(46):41-55.
- Bobrovs V, Olonkins S, Ivanovs G, Poriņš J (2013). Comparative performance of Raman-SOA and Raman-EDFA hybrid optical amplifiers in DWDM transmission systems. Int. J. Phys. Sci. 8(39):1898-1906.
- Bobrovs V, Ozoliņš O, Ivanovs Ģ, Poriņš J (2010). Realization of HDWDM transmission system. Int. J. Phys. Sci. 5(5):452-458.
- Bobrovs V, Ivanovs Ģ, Spolitis S (2011). Realization of combined chromatic dispersion compensation methods in high speed WDM optical transmission systems. Electr. Electr. Eng. 10:33-38.
- Cisco Systems (2010). Cisco Visual Networking Index – Forecast and Methodology 2009–2014. White, pp. 1-17.
- Dutta AK, Dutta NK, Fujiwara M (2003). WDM technologies: Passive optical components. USA: Academic Press, 551(4).
- Mukherjee B (2006). Optical WDM networks. Springer, P. 973. PMID:16214352
- OptSim User Guide (2008). USA: RSoft design group Inc., P. 404.
- Trifonovs I, Bobrovs V, Ivanovs G (2011). Optimization of a Standard Bidirectional DWDM Solution. Electr. Electr. Eng. 9:37-40.
- Udalcovs A, Bobrovs V, Ivanovs G (2011). Investigation of differently modulated optical signals transmission in HDWDM systems. Computer technology and applications by David Publishing Company, USA. 2(10):801-812.