

Full Length Research Paper

Development of 0.5 HP induction motor with reduced slots in rotor and stator core and its performance evaluation

I. Daut, K. Anayet*, N. Gomesh, M. Irwan, M. Asri and M. A. Rashid

School of Electrical Systems Engineering, University Malaysia Perlis (UniMAP), 01000 Perlis, Malaysia.

Accepted 17 February, 2012

In this paper, we have developed a new prototype of 0.5 hp induction motor with reduced slots in rotor bar and stator core in comparison to the conventional induction motor. The conventional induction motor usually uses 30 slots of aluminum rotor bar and 36 slots in the stator core. In our developed prototype, we used 10 slots of copper rotor bar and 24 slots in the stator core. In order to evaluate the performance of this new prototype, we measured various losses such as core loss, copper loss, friction and windage losses, rotor loss and stray loss and compared them with the 0.5 hp conventional induction motor. The comparison results revealed that the developed prototype provide with a significant reduction, the motor losses. As a result, the efficiency of the new prototype is greatly improved.

Key words: Induction motor, 10 slots copper rotor bar, 24 slots stator core, non-grain materials.

INTRODUCTION

Induction motors (IMs) are widely used in various sectors, including industrial, residential, commercial building, transport system, communication, public and household sectors. It is documented that the IMs consume about 75% of the electrical energy consumed by all electric motors in a country, which is in fact the equivalent to about 43% of the total electrical energy consumption of a country (Nadel et al., 1992). We also noticed that 1% increase in motor electrical energy efficiency can save 20 billion kWh per year or 1.4 billion dollars in electricity and 3.5 million barrels of oil in the United States (Peters et al., 2003c). It has been the current demand of the society to develop high efficiency low cost IMs. By using low cost high efficiency IMs, we can save the national revenue as well as the environment from global warming.

The IM manufacturers know that the substitution of aluminum by copper for the squirrel cage rotor can significantly reduce the motor losses and improve the

efficiency (Peters et al., 2003a, b; Brush et al., 2003). The incorporation of copper for the rotor bars and end rings in place of aluminum would result in attractive improvements in motor energy efficiency (Francesco and Marco, 2003). Some manufacturers claim that an increase in active materials (electrical steel and copper) in building electric motors can increase the efficiency of the IMs (Peter and Paolo, 2003). Some researchers found out that the influence of stator slot shape shown reducing its magnetizing current and overall efficiency boost up around 5% as compared to the existing motor. The new shape design of the stator slots also indicate for iron loss reduction of the motor (Sundaram et al., 2011; Park et al., 1995). Copper has many advantages over aluminum in electric motors rotor construction, because of its higher temperature capability as well as the stress capability at higher temperatures (Dymond and Findlay, 1995). Copper rotor die castings were of high quality and had no significant porosity in the conductor bars of the electric motors (Peters et al., 2003b; Ace Copper Concepts Inc, 2004-2011). It is therefore a natural choice of using copper for rotor bar material of an induction motor (Dymond and Findlay, 1995).

The conventional IMs available in the market are

*Corresponding author. E-mail: anakarim05@yahoo.com, anayet@unimap.edu.my. Tel: +6 0164255712. Fax: +6 9851431.

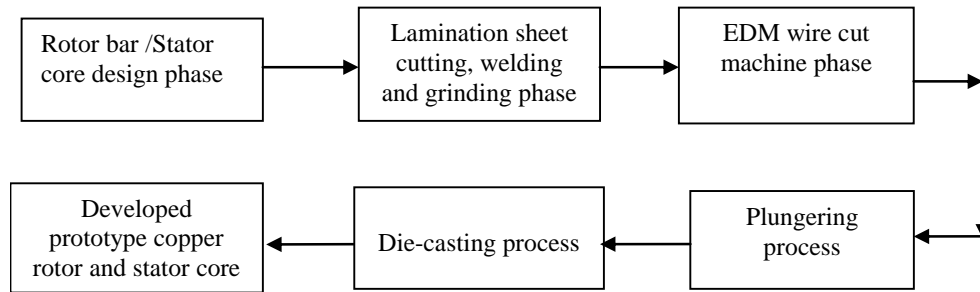

Figure 1. Basic flow diagram of the development process of copper rotor and stator core.

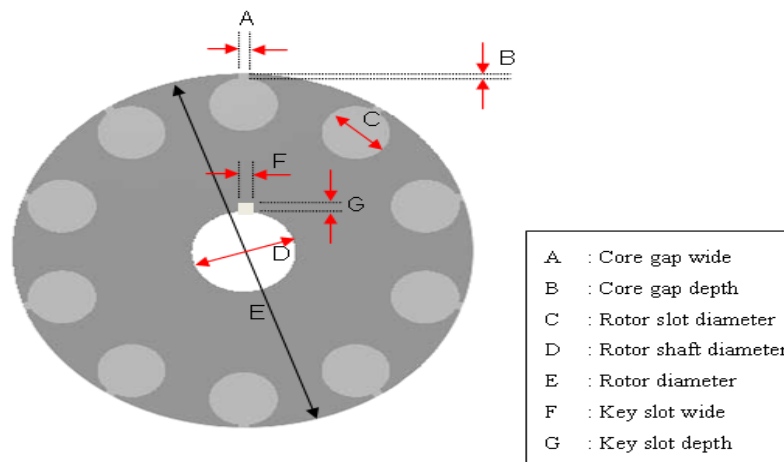

Figure 2. Copper rotor slots view in AutoCAD (10 slots).

mainly composed of aluminum or aluminum alloy with mostly 30 slots in the rotor bar and 36 or more slots in the stator core. In order to develop low cost and high efficiency IM, we choose reduced slots in both rotor bar and stator core. We used 10 slots copper rotor bar and 24 slots stator core in our developed prototype. We changed the dimension in stator teeth width, teeth neck and length of the slots. Finally, we investigated and tested our developed prototype IM in our well equipped electrical machine laboratory at UniMAP. We evaluated the performance of this prototype by measuring various parameters in order to get motor losses, such as core loss, copper loss, friction and windage loss, stray loss and rotor loss, and compared with a conventional induction motor of 0.5 hp with 30 slots in rotor bar and 36 slots in stator core. We found out that our developed prototype IM provides better performance as compared to the conventional one.

The main objective of this study is to develop a 0.5 hp three-phase induction motor with 10 slots copper rotor and 24 slots stator core. A special emphasis has been given on the designing of copper based rotor for replacing the existing aluminum rotor in order to improve

the efficiency by reducing the motor losses. As a result, more energy would be saved. A detailed cost and benefit analysis of energy savings was performed to draw the attention of motor users as well as manufacturers.

MATERIALS AND METHODS

A series of steps are necessary to develop a prototype induction motor. We followed the steps as shown in Figure 1 in developing the copper rotor bar and stator core of our developed prototype IM. As we follow the same procedure in the case of the stator core, we did not show flow diagram for developing stator core.

Development process of copper rotor bar and stator core

We followed the steps as shown in Figure 1 in developing the copper rotor bar and stator core of our developed prototype IM.

Rotor bar and stator core design phase

This phase is the starting phase for the development process of our prototype copper rotor bar and stator core. We calculate the rotor bar area and stator slot area for the prototype. We used AutoCAD design dxf file to perform the design work as shown in Figure 2.

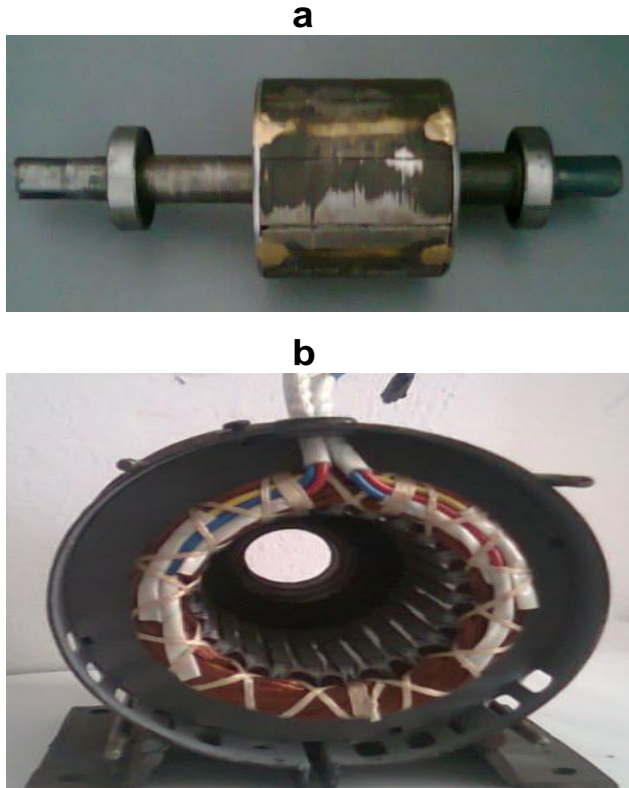

Figure 3. Developed prototype of copper rotor and stator core of induction motor: (a) copper rotor and (b) stator core.

Lamination sheet cutting, welding and grinding phase

In this phase, the lamination steel sheets (grade H10 non-grain) were cut based on the specifications as obtained from design phase, which was 150×150 mm with the thickness of 0.35 mm. Then, 220 pieces of single laminations sheet are divided into two lamination stacks, because the electro discharge machine (EDM) wire cut machine cannot cut more than 45 mm length of lamination stack. The 100 pieces of lamination steel sheets are stacked and welded together. In order to make the stacks smooth, the grinding process was done so that the stacks can be fit with EDM wire cut machine without further interruption.

EDM wire cut machine phase

The EDM model AQ 327L was used to cut the lamination stacks based on the design specification as obtained from design phase. Here, we need to upload AutoCAD dxf file in EDM machine and operate under high temperature of 11000 to 13000°C on the conductor wire as to melt the material during the cutting process. The EDM uses 0.25 mm diameter non paraffin hard wire which is made of brass materials to cut the lamination stack.

Plungering process

Plungering is the process of pressing the metal copper powder into the slot of the rotor circuit of the motor. The plunger was used to compress the metal copper powder into the slot with force of 3 to 5 tons using the pressing station which consists of hydraulic press

that could apply maximum force of 10 tons.

Die-casting process

This process was used to harden the metal copper powder, permanently, which was inserted by plungering unit into the rotor slot. The furnace was used to bake the copper for 9 h continuously. At the beginning of the baking process, the temperature was set to 200°C for 2 h. Next, the process was repeated for temperature of 860°C for 5 h. Finally, the baking process was cooled for 2 h. Before the argon gas supplied to the furnace, the pressure gauge and flow meter was installed in the tank of the argon gas. Water filled with soap was sprayed along the tube and joints to make sure that the argon gas does not leak during this process.

Developed prototype copper rotor and stator core of induction motor

The developed prototype of copper rotor and stator frame are as shown in Figure 3a and b.

PERFORMANCE EVALUATION

Here, we evaluated the performance of our developed prototype of 0.5 hp induction motor and compare it with the conventional 0.5 hp IM. We calculated copper loss, core loss, stator resistance, no load input power and friction and windage loss by conducting some experiments in our laboratory.

No-load test of induction motor

We calculate the copper loss (I^2R) in the stator windings, friction and windage losses, core loss, rotational losses, no-load resistance, reactance, impedance, magnetizing reactance and rotor current by measuring some parameters under this test (Bhattacharya, 2009; Juha and Tapani, 2008; Jimmie, 2001; Sen, 1997). The experimental set up for the no-load test is as shown in Figure 4. The test data for existing aluminum rotor with existing stator core and for new copper rotor with new stator core are as shown in Table 1.

The motor was connected to the rated voltage and frequency. The motor was run without any load until the input reading stabilized. This can take from 1 to 4 h to be stable condition. Once the motor has "warm up" or stabilized, testing proceeds by adjusting the motor voltage and taking a series of readings from approximately 20, 40, 60, 80 and 100% of motor rated voltage down to a minimum voltage where motor current no longer continues to drop with voltage. Slip of the motor found very small at no-load condition.

The no-load input power comparison between newly developed prototypes of 0.5 hp IM with existing conventional IM with aluminum rotor bar is as shown in Figure 5. As shown in Figure 5, less input power is required to run the new IM than conventional one. A graph of power versus voltage was plotted for both types of induction motor. The friction and windage loss graph is as shown in Figure 6. Friction and windage losses can be reduced by improving the bearing and fan selection of the induction motor.

DC resistance test of induction motor

The test to obtain the value of R_1 is called DC resistance test.

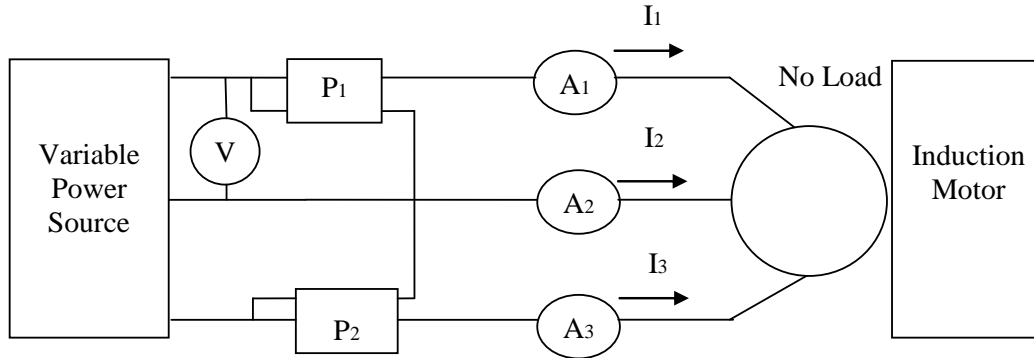

Figure 4. Schematic diagram for No-Load Test of 3-Phase IM.

Table 1. Test results of 0.5 hp induction motor for existing aluminum rotor with existing stator core and new copper rotor with new stator core.

Variac voltage (3-phase)	Copper rotor with new stator core				Aluminum rotor with existing stator core			
	Input Current	Power factor	Input power	Speed	Input current	Power factor	Input power	Speed
50	119.30	0.314	3.24	1391.5	125.67	0.314	3.50	1385.5
100	146.20	0.259	6.55	1481.3	160.6	0.259	7.45	1425.2
175	148.50	0.226	10.17	1480.7	180.7	0.226	13.25	1450.7
220	154.30	0.225	13.22	1482.6	195.2	0.225	17.25	1468.2
240	164.40	0.218	15.50	1482.6	205.5	0.218	19.26	1477.3
300	168.20	0.251	21.93	1483.2	228.2	0.221	28.20	1478.2
350	175.90	0.262	27.93	1483.2	245.70	0.242	38.10	1480.3
400	188.95	0.270	35.34	1483.2	285.30	0.262	53.45	1480.5
415	199.95	0.330	47.42	1495.9	315.0	0.352	80.95	1480.5

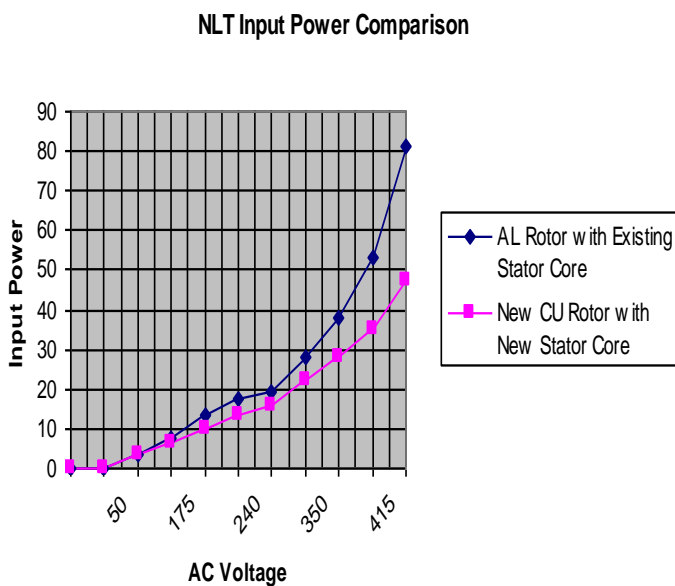

Figure 5. No-load Input power comparison between new prototype IM and existing conventional IM.

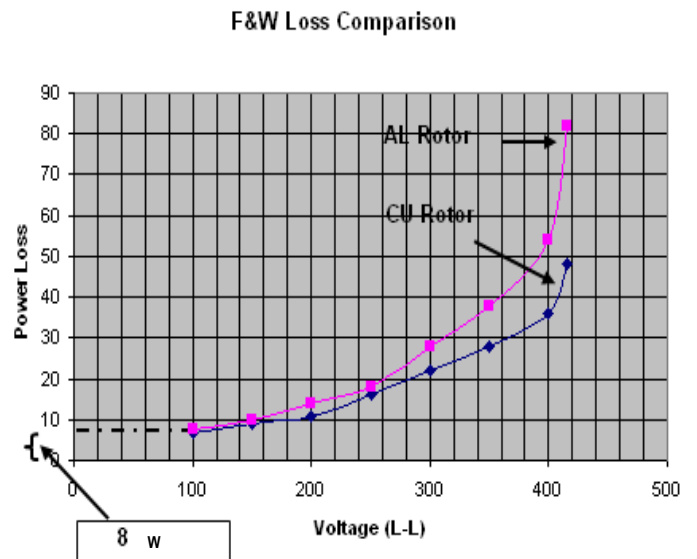

Figure 6. Friction and windage (F&W) loss comparison between aluminum rotor with existing stator core and new copper rotor with new stator core of induction motor.

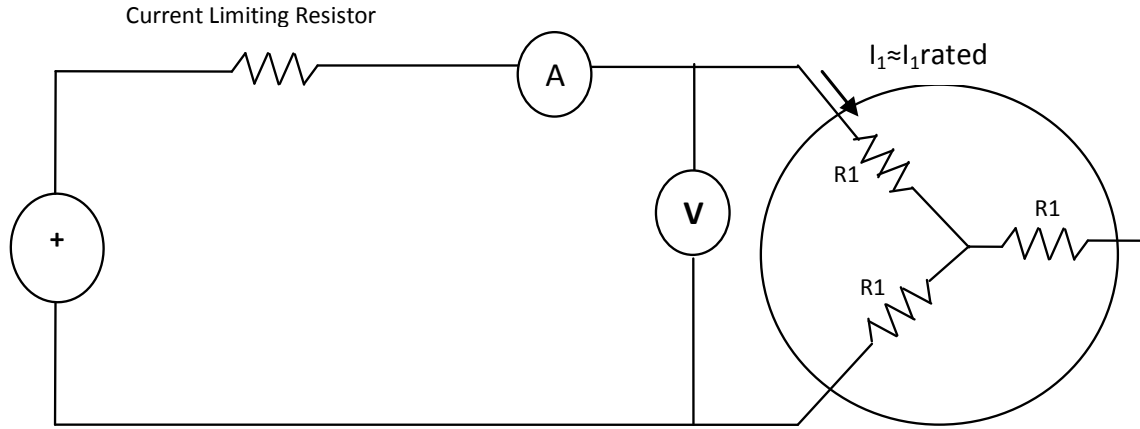

Figure 7. DC resistance connection diagram of IMs.

Table 2. DC resistance test data for existing aluminum rotor with existing stator core and new copper rotor with new stator core.

Variable resistor (kΩ)	Power supply (V)	DC resistance test data for copper rotor with new stator core			DC resistance test data for aluminum rotor with existing stator core		
		V _{dc} (V)	I _{dc} (mA)	R ₁ (Ω)	V _{dc} (V)	I _{dc} (mA)	R ₁ (Ω)
10	5	0.022	0.52	21.15	0.027	0.55	24.60
	10	0.046	1.02	22.55	0.056	1.10	25.45
	15	0.071	1.56	22.76	0.078	1.60	24.40
	20	0.092	2.05	22.43	0.10	2.10	23.90

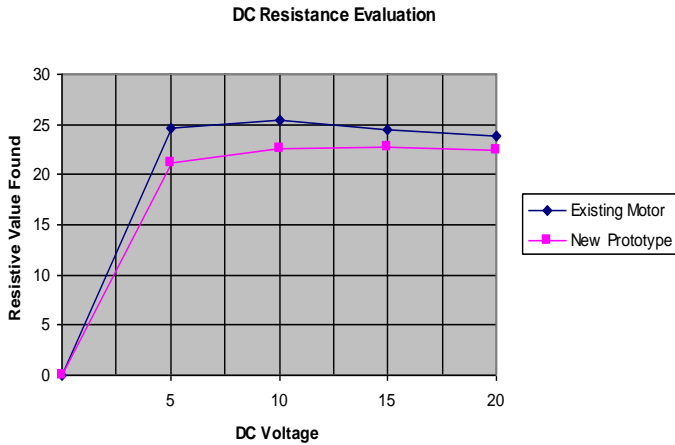

Figure 8. DC resistance comparison for aluminum rotor with existing stator core and copper rotor with new stator core of induction motor.

Basically, a DC voltage is applied to the stator windings of an induction motor. By applying DC current, there was no induced voltage in the rotor circuit and no resulting rotor current flow. At this level, the reactance of the motor is zero at direct current. Therefore, the only quantity limiting current flow in the motor is the stator resistance and the resistance can be determined. The experimental

set up for DC resistance test is as shown in Figure 7 and the results of DC resistance test data for existing aluminum rotor with existing stator core and new copper rotor with new stator core are as shown in Table 2.

To calculate the stator resistance R_1 , the following equations was used.

$$2R_1 = \frac{V_{DC}}{I_{DC}}$$

that is,

$$R_1 = \frac{V_{DC}}{2I_{DC}} \tag{1}$$

During DC resistance test, the stator winding was fed with the motors DC voltage and current, and then, the stator winding resistance found 25.45 Ω for existing aluminum rotor with existing stator core and 22.55 Ω for new copper rotor with new stator core of induction motor, as shown in Figure 8. The core loss comparison for aluminum rotor with existing stator core and copper rotor with new stator core of induction motor is as shown in Figure 9.

Blocked rotor test setup of induction motor

The blocked-rotor test on an induction motor, like the short-circuit

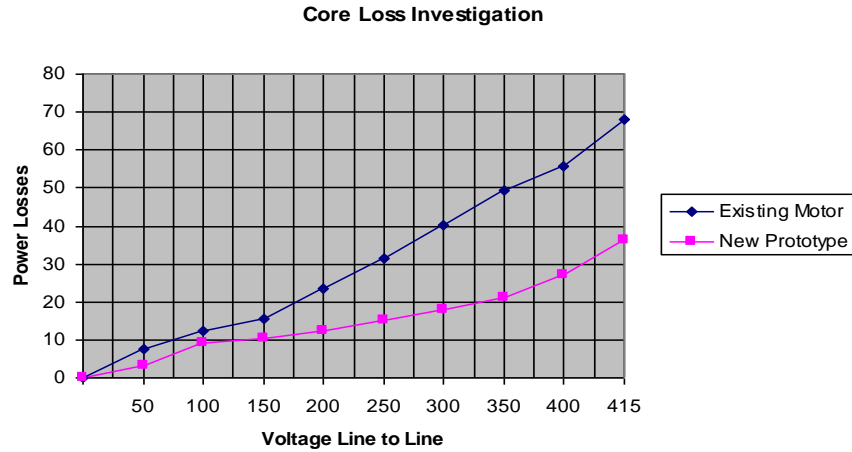

Figure 9. Core loss comparison for aluminum rotor with existing stator core and copper rotor with new stator core of IMs.

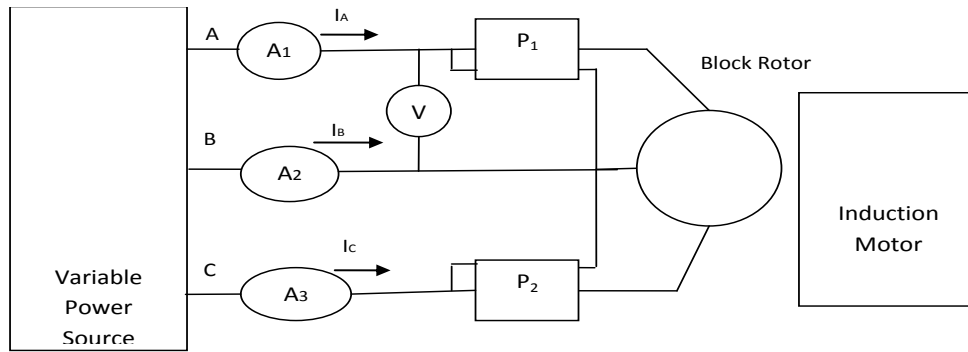

Figure 10. Blocked rotor test connection diagram.

Table 3. Block rotor test data for existing aluminum rotor with existing stator core and new copper rotor with new stator core.

Variat 3-phase supply (V)	Block rotor test data for copper rotor with new stator core			Block rotor test data for aluminum rotor with existing stator core		
	Input current	Power factor (pf)	Input power (W)	Input current	Power factor (pf)	Input power (W)
30	155.20 m	0.80	6.45	168.20 m	0.680	6.11
60	490.5 m	0.80	40.77	499.0 m	0.750	38.89
90	865.3 m	0.80	107.90	840.1 m	0.740	96.89
120	895.2 m	0.820	152.55	889.0 m	0.780	144.12
150	0.90 m	0.850	198.75	1.04 A	0.81	218.85

test on a transformer, gives information about leakage impedances i.e. rotor resistances. In this test the rotor is blocked so that the motor cannot rotate, and balanced poly-phase voltages are applied to the stator terminals at reduced rate i.e. voltage is gradually increased to a value so that full rated current flows through the windings of the motors. The core or iron-losses will be very small under this test. The power taken by the motor when rotor is blocked is almost entirely due to copper losses. With increase in stator

applied voltage, the losses will increase as the square of the current. The experimental set up for blocked rotor test is as shown in Figure 10 and the results of block rotor test data for existing aluminum rotor with existing stator core and new copper rotor with new stator core are as shown in Table 3. The sum of 2 W_m readings gives the total input power. Since full load current is allowed to flow through the stator and rotor windings, the input power can be considered approximately equal to the full load

Block Rotor Input Power Comparison

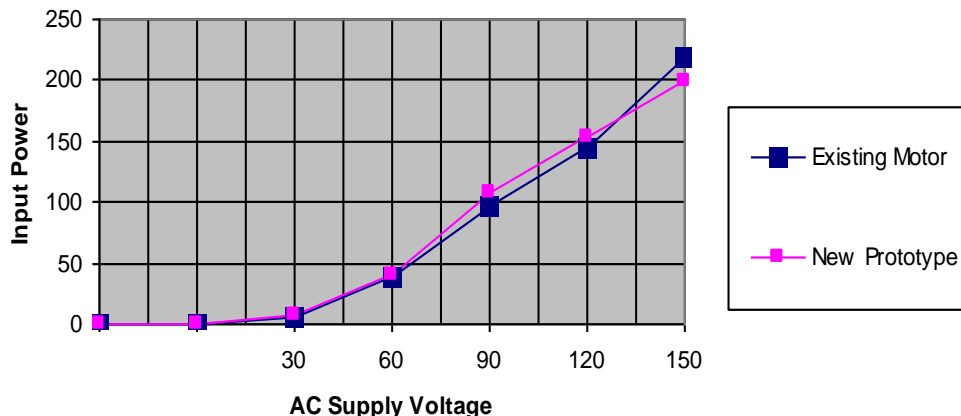

Figure 11. Input power comparison in block rotor test.

Existing AL rotor & New CU rotor Performance Comparison

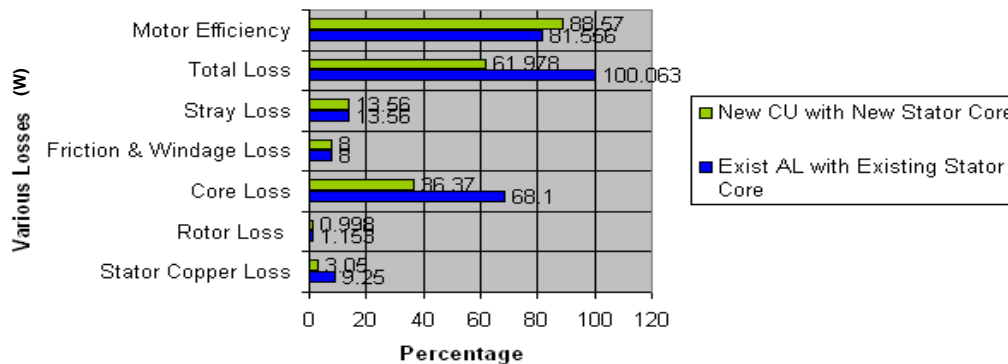

Figure 12. Aluminum rotor with existing stator core and copper rotor with new stator core performance evaluation of induction motor.

I^2R losses. From the input power, it is possible to calculate the equivalent resistance of the motor referred to as the stator terminals. By knowing the value of resistance, we can calculate the values of I^2R loss at no load condition (Bhattacharya, 2009; Juha and Tapani, 2008; Jimmie, 2001; Sen, 1997). The input power comparison, during block rotor test for aluminum rotor with existing stator core and copper rotor with new stator core of induction motor are as shown in Figure 11.

A performance bar graph was plotted based on various losses as shown in Figure 12. It shows the loss segregation, total loss and motor efficiency. The efficiency of the induction motor for aluminium rotor with existing stator core was found to be 81.556% and for copper rotor with new stator core was found to be 88.57% and the losses is reduced up to 38.085 W. This shows that copper rotor can increase the efficiency and reduce the overall losses of the induction motor. The efficiency difference for both types of induction motors is around 7.014%. Therefore, the new set up can improve efficiency to 7.014% of the induction motor and can save 291.75 kWh per year per unit which makes huge contribution to the national economy of Malaysia.

RESULTS AND DISCUSSION

It was found out, during no load test, that input power for the new copper rotor with new stator core is 47.42 W and for the aluminum rotor with existing stator core is 80.95 W as shown in Figure 5. The friction and windage losses were found approximately as 8 W for both types of motors as shown in Figure 6, which is the same and independent of material type. Friction and windage losses could be reduced by improving the bearing and fan selection of the induction motor.

Furthermore, we conducted DC resistance test and found stator winding resistance of 25.45 Ω for aluminum rotor with existing stator core, whereas 22.55 Ω for new copper rotor with new stator core of induction motor as shown in Figure 8. Then, we calculate and found the total losses (summation of core loss, copper loss, friction and windage loss) to be 47.42 W for the new prototype and

85.35 W for existing aluminum rotor with existing stator core of induction motor.

We noticed that the core loss of copper rotor is reduced by 46.59% as compared to the existing aluminum rotor. The difference in core losses in both cases is illustrated in Figure 9. During block rotor test, the input power was found to be 198.75 W for copper rotor and 218.85 W for aluminum rotor which is slightly higher than copper rotor as shown in Figure 11. It was found out that the rotor loss for copper rotor is less than aluminum rotor by 13.44%.

Finally, we found out that the total losses of 61.978 W in the case of copper rotor with new stator core and 100.063 W for aluminum rotor with existing stator core. The difference is 38.085 W between the losses of two motors. The overall efficiency of the new prototype was found to be 7% improvement that can save annual energy savings of 291.75 kWh per year by each unit, which is equal to RM 97.94 per year basis.

Conclusion

We developed a new prototype of 0.5 hp induction motor with 10 slots of copper rotor bar and 24 slots in the stator core. In order to evaluate the performance of this new prototype induction motor, we measured various parameters to estimate the motor losses, such as core loss, copper loss, rotor loss, friction and windage loss as well as stray loss. The estimated losses were compared with those of a conventional 0.5 hp induction motor. We found no remarkable changes in friction and windage loss, stray loss and rotor loss in both cases. But we found 67% reduction of copper loss and 46.5% reduction of the core loss in the case of our new prototype induction motor as compared to the conventional one. As a result, the overall efficiency of the developed new prototype was greatly improved, which was found to be 7% improvement as compared to conventional induction motor.

ACKNOWLEDGEMENT

The authors would like to thank School of Electrical Systems Engineering, University Malaysia Perlis (UniMAP) for the technical and financial support.

REFERENCES

- Ace Copper Concepts Inc. (2004-2011). Retrieved on July 15, 2011 from <http://www.acemagnetics.com/copper-info.html>.
- Bhattacharya SK (2009). *Electrical Machines*. Tata McGraw-Hill Publishing Company Limited, New Delhi, India, pp. 394-403.
- Brush EF, Peters DT, Van Son DJ (2003). Die-Cast Copper Motor Rotors: Motor Test Results, Copper Compared to Aluminum. *Energy Efficiency in Motor Driven Systems*, Editors: Parasiliti F, Bertoldi P. Springer, pp. 36-143.
- Dymond JH, Findlay RD (1995). Some Commentary on the Choice of Rotor Bar Material for Induction Motor. *IEEE Trans. Energy Conversion*, 10(3): 425-430.
- Francesco P, Marco V (2003). Design of High Efficiency Induction Motors with Die-Casting Copper Rotors. *Energy Efficiency in Motor Driven Systems*, Editors: Parasiliti F, Bertoldi P. Springer, pp. 144-151.
- Jimmie JC (2001). *Electric Machines Analysis and Design Applying MATLAB*. McGraw-Hill Higher Education, New York, USA, pp. 319-355.
- Juha P, Tapani J (2008). *Design of Rotating Electrical Machines*. John Wiley & Sons Ltd., New Delhi, India, pp. 301-313.
- Nadel S, Shepard M, Greenberg S, Katz G, Almeida AT (1992). *Energy-Efficient Motor System*. American Council for an Energy-Efficient Economy (ACEEE), Washington DC., pp. 1-23.
- Park SB, Lee HB, Hahn SY (1995). Stator slot shape design of induction motors for iron loss reduction. *IEEE Trans. Magn.*, 31(3): 2004-2007.
- Peter JT, Paolo C (2003). Practical Issues in the Manufacture of High Efficiency Electric Motors. *Energy Efficiency in Motor Driven Systems*, Editors: Parasiliti F, Bertoldi P. Springer, pp. 202-210.
- Peters DT, Cowie JG, Brush EF (2003a). Die-Cast Copper Motor Rotors: Die Materials and Process Considerations for Economical Copper Rotor Production. *Energy Efficiency in Motor Driven Systems*, Editors: Parasiliti F, Bertoldi P. Springer, pp. 144-151.
- Peters DT, Brush EF, Van Son DJ (2003b). Development of the Copper Motor Rotor-Manufacturing Considerations and Test Results. *INDEX*.
- Peters DT, Cowie JG, Brush EF Jr (2003c). The die-cast copper motor rotor - A new copper market opportunity. *Copper Development Association Inc. 27 Raintree Lane, Hilton Head Island, USA.*, pp. 1-32.
- Sen PC (1997). *Principles of Electric Machines and Power Electronics*. John Wiley & Sons Inc., USA, pp. 229-239.
- Sundaram M, Navaneethan P (2011). On the Influence of Stator Slot Shape on the Energy Conservation Associated with the Submersible Induction Motors. *Am. J. Appl. Sci.*, 8(4): 393-399.