

Full Length Research Paper

Social organization and cultural institutions of the *Afar* of Northern Ethiopia

Kelemework Tafere Reda

Social Anthropology, Mekelle University, P. O. Box 175, Mekelle, Ethiopia. E-mail: kelem40@yahoo.com.
Fax: 251 344 407610.

Accepted 1 June, 2011

An anthropological study was conducted on the social organizations and traditional cultural institutions of the *Afar* pastoral society in northern Ethiopia. This paper describes the clan-based institutions that are central to *Afar* culture and cosmology. Gerontocracy (the rule of elders), well established economic and political support networks and a patriarchal authority at all levels feature in the *Afar* mode of life. Descent is traced through the male line and women, while substantially contributing to household income earning, occupy only a marginal place in the society. The *Afar* people are known for their efficient communication skills and institutions. They are well versed and articulate in expressing their views in a disciplined manner, often consolidating their arguments using carefully selected idiomatic expressions and proverbs.

Key words: *Afar*, culture, institutions, Ethiopia.

INTRODUCTION

The *Afar* people are Cushitic-speaking people living in the arid and semi-arid areas of Ethiopia, Eritrea and Djibouti. Outsiders have used many different terms to refer to the *Afar*. These terms include Danakil, Adal and Taltal, even though the *Afar* liked none of them (Piquet, 2002). The *Afar* inhabit an inhospitable land and their total number in Ethiopia is reported to be 1,098,184 (Central Statistical Authority, 2006). The *Afar* are classified into two distinct descent groups: the Asaimara (red) and Adaimara (white). The former are considered a nobility group, while the latter are said to form the class of the commoners (Markakis, 2004). The *Afar* is Sunni Muslims. Islam is believed to have been first introduced into the *Afar* by migrant Arabs as early as the ninth century or earlier. Then it was spread across many places by *Afar* merchants from the coast and non-*Afar* people from neighbouring areas such as Harar and Argoba (Getachew, 2001).

Historically, the economy of the *Afar* was based on multi-species livestock husbandry. But with increased vulnerability to drought and famine due to ecological disasters, they now depend mainly on camel and goat pastoralism. Today, some *Afar* people are agro-pastoralists who combine animal husbandry with marginal agriculture. Their settlements are semi-permanent

situated near permanent water sources and small trading centres (Yaynshet and Kelemework, 2004).

MATERIALS AND METHODS

This anthropological study was conducted in Zone 2 administration of the *Afar* Regional State, Ethiopia. The specific localities considered for this study were *Ab'ala*, *Asangola*, and *kala* areas. Selection of such sites was made on the basis of variations in lifestyle and modes of livelihood. While the *Afar* people in *Ab'ala* are mostly sedentary, those in *Asangola* and *Kala* localities represent semi-nomadic pastoralists in the region.

The data for this paper was collected using qualitative methods. Ethnography was the major data collection method used. Specific tools for data collection include participant observations, focus group discussions, key informant interviews and case studies. The focus group discussions were conducted with groups consisting of 6 to 8 community members representing the different gender, age, income and social categories. A total of 16 FGDs were conducted in all the three localities. Key informant account was obtained from 36 elderly and knowledgeable personalities in the villages. 53 local residents were also considered for semi-structured interviews which, for most part, took place in their homes. Microcassette recorders and other electronic gadgets including photo cameras were used in the process of gathering appropriate data for the study. The unit of analysis in this paper is the community. Village level information is

presented in a descriptive way along with the author's analytical perspectives.

RESULTS AND DISCUSSION

Kinship, marriage and territorial organization of the Afar

The Afar has a social organization which is similar to that of other pastoral societies in Africa such as the Somali. Central to the Afar social structure are descent and affinal ties. The Afar have a patrilineal descent system based on which a person belongs to a particular clan (*mela*). Afar settlements are composed of a mixture of clans although each locality is identified with a major clan and affines. This makes it easier to organize social, economic and political support in times of crisis. Clan members are expected to share resources and help each other in emergencies. Such support becomes practically difficult to claim when members of a kinship group or a particular clan are far apart. The current dispersion of Afar over distant areas within and outside Ethiopia in search for wage employment is thus considered by many Afar as a setback to clan solidarity in many respects, including dispute settlement. According to some writers, the Afar have a saying related to intra-clan sharing behaviour: "*Sagage'ri nama lakal masa*" (Literally: a cow's tail is equidistant from both its legs.) This means: Those belonging to the same group share and share equally, both the good and bad.

Hence, residents either belong to the same clan or are marital relatives. But in each settlement there are also local groups as movement into and out of these settlement areas is more or less free. Getachew (2001) has observed that the Afar try to maintain solidarity through a strong clan identity. Majority of the Afar who have migrated to other places establish strong links with their place of origin in the rural areas through regular visits, sending remittances back home.

There are several clans in northern Afar of which the dominant are Seka, Damohita, Dahimella, and Hadarmo. Each clan is divided into several sub-clans and lineages (*Affa*). Clans are represented by clan heads, who access leadership status based on their age, strength in decision-making and overall credibility in the society. Leadership positions are sometimes accessed through inheritance. Upon the death of a clan head, his sons will be considered for the position but if they lack the necessary quality of leadership, an election may be arranged.

Clan heads are entrusted with the responsibility of regulating the behaviours of clan members. They are also expected to mobilise clan members for some positive pursuits, including co-operation in certain domestic activities and raising money for compensation for any physical or psychological damage caused upon others during violent conflict. They make sure that every clan member is socially, economically and politically secure. As

a result of this burden, it is not uncommon for people to reject proposals for heading a clan. This also signifies that loyalty to clan leaders should be maintained at all cost.

The Afar expresses this through a proverb: "*Essi Amoita Hamita Mella Ke Daar Akak Maki Me Garbo Aysuk Matayssa*" (A forest through which a river has ceased to run, and a clan even slightly unfaithful to its leader are both on the decline).

In terms of size, the Seka clan is largest. In fact it is said that the town of Ab'ala is also named Shiket because it is largely inhabited by members of the Seka clan. Members of this clan are believed to have religious power. Politically, however, the Damohita clan is dominant and can be considered aristocratic. For these reasons the Damohita and Seka clans play significant roles in dispute settlement processes as ritual leaders.

The Afar practice exogamous marriage and polygamy is exercised in accordance with Islamic laws. There are several marriage patterns. These include inter-clan marriages between unrelated people, cross-cousin marriages (*Absuma*) and leviratic arrangements (widow inheritance). It is claimed that cross-cousin marriages are stronger than marriages between unrelated persons because no serious harm is inflicted on ones own blood and flesh in times of conjugal conflict. In the interior parts of north Afar country, cross-cousin marriages are almost always mandatory. In some areas particularly in the south fierce inter-clan fighting may arise as a result of failure to adhere to such a norm. In areas close to the ethnic borders, however, such a norm is loosely observed as a woman can marry men other than her mother's brother's sons (Figure 2).

On the other hand parallel cousin marriages are strictly forbidden for cultural reasons. One informant commented: "even though this [parallel cousin marriage] is not completely forbidden (*haram*) in religious terms, our *Ada* [custom] does not allow us to exercise it." There is, of course, an explanation for this. A person cannot marry his father-brother's daughter because ideally these children belong to one father. A Father-brother may, upon the death of father, replace the biological father and marry the widow of his deceased brother. The same applies for the mother-sister's children. In short, father- brother and the mother-sister are potential fathers and mothers.

Betrothal for marriage engagements may begin during childhood. This is done following a nominal payment in cash. The actual wedding however usually takes place when girls reach their mid teens during which there is a transfer of bride wealth (*alekum*) amounting to about 1000 Birr or more. The amount to be paid in bride-wealth varies from family to family as it is ultimately decided, in negotiations, by the girl's father. The paid money is partly spent on the purchase of some food items and material for establishing an Afar mat house (*Senan Ari*) for the new couple.

Wedding ceremonies take place in the house of the bride's family where friends and relatives enjoy their

porridge. Upon marriage, residence is normally patrilocal and the couple may stay there until the bride gives birth to a child. If the husband wants to take his wife, he has to pay 30 to 50 Birr to her family. This money is actually used for buying butter (*subah*) and wheat flour for the newly married couple. This is done on one market day (Thursdays). A few days later, the boy's father brings two camels, loads them with the butter (*subah*), wheat flour and mat (*Senan*) and takes the couple to the place where they will construct their own house. The wife's mother usually accompanies the couple to help them construct their house and returns home after three days. When the wife gets pregnant, the husband usually takes her back to her family for delivery. The husband would then dismantle the mat house.

After a period of up to four months following delivery, sometimes after a whole year, the couple return to their home, which they would have to re-erect. The same procedure is commonly followed at the second and third pregnancies. Depending on the capacity and willingness of the husband to support his wife economically and socially, a wife may continue to deliver at her parents' home even after the fourth child. The northern *Afar* tend to have as many children as possible. One justification for this is that children are viewed as an opportunity for the diversification of household income as they may engage in a variety of activities, such as trade, salt caravans, labours migration and herding thereby averting the consequences of a decline in income from any one particular activity. In the early years of marriage, however, the birth of many children may constitute a burden on the husband. One common solution is migration by the husband to Saudi Arabia or Djibouti in which instance the wife and children move to live with the wife's parents.

As highlighted earlier, it is evident among the northern *Afar* (conceivably more than in the southern part of the *Afar* region), that people adopt sororate and levirate marriage arrangements. A man is forced to marry his brother's widow when the original husband dies. Similarly, a woman must replace her sister as a wife when the latter passes away. This practice is said to be for the sake of the children of the widow (*Gubna*) or that of the widowed (*Ardiglu*). In accordance with Islamic laws, for a few months after the death of her husband, a widow (*Gubna*) is expected to exhibit some self-punishing behaviours including avoiding luxury things such as delicious food, perfume and so on.

Summing up, the *Afar* social organization is highly segmented with small social units such as clans, sub-clans, lineages, and households. Each of these has the autonomy to deal with its own domestic matters. Within these units, kinship groups enjoy a multitude of reciprocal rights while at the same time fulfilling certain obligations that are instrumental for inter-group solidarity, and continuity of the group as an economically and socially viable entity. Within a pastoral context, the rights and obligations include, the sharing of bride wealth and blood

money, the reciprocal exchange of gifts at different occasions and the partnership in livestock husbandry. Reciprocity established through sharing not only prevents overgrazing but also serves as means of building social capital, which is a useful asset during periods of economic and political hardship such as drought and conflict.

Social status, property relations, and household decision making

In typical *Afar* households, men are heads of respective families. Men are generally accepted as an authority figure and have the greatest share of rights over property and children. Household heads also decide on such matters as mobility and sale of livestock. Although household decision-making is often based on subsequent negotiations with women, men have the ultimate say. Livestock may be owned individually although they are regarded as assets of the entire household. Children have their own livestock. Following birth, a child receives female goats or a camel "to see the luck". This takes place during initiation ceremonies such as circumcision or the tying up of the umbilical cord. If the animal reproduces and survives environmental hazards, the child is considered lucky. First-born babies have the advantage of getting more animals. Female children often receive fewer animals than male children. Women generally occupy a lower social status in *Afar* society. When the head of the family dies, moreover, daughters do not inherit property on an equal basis with sons. Should the children of the deceased father be females only, the father's close agnatic kin (especially the father's-brother) will have a share.

The household division of labour is based on gender and age. Accordingly, male adults manage the herd and the household. The husband undertakes the herding, milking and selling of animals (often following discussion with his wife). The wife, on the other hand, fetches water, grinds grains, and prepares food in the house. She also sells small stock animals and ropes (*Aketa*). Women are also actively involved in the preparation of temporary shelters (*Senan Ari*) for newly married couples.

Children assume a prominent role in herding and related activities. Calves and small stocks are tended in the nearby areas by children (boys and girls) and sometimes by female adults. Most adult men do not normally carry out manual work unless they are poor and do not have grownup children. They are responsible for managing all matters pertinent to the household and the community at large, for example, defending the family and its herd from wild animals and raiders, settling legal disputes, marriages, bride-price, marital problems and arranging ritual ceremonies. Otherwise, they have to do the much harder task of herding camels in far away places.

The basic resources (livestock and land) are mainly under the control of men who are responsible for the



Figure 1. The Afar people interact with other cultural groups in the local market.

major economic decisions of purchasing and marketing of proceeds. Although women are excluded from major decision-making and control limited resources, they make decisions and have control on the income from sales of milk products and skins. With reduced herd sizes, the quantities of these products are decreasing and thus the role of women in their control is also decreasing. There are cases where women own some animals but they cannot make major decisions, such as how to dispose them without the husbands' permission.

Some writers (Markakis, 2004) have pointed out pastoralism is not only a mode of production but also a way of life and a culture. The two features are closely related. The *Afar* case is no exception.

Afar pastoralists are well aware of the dilemmas in their mode of production and tend to take rational actions as coping mechanisms with the aim of easing the burden on pastoral resources by minimizing herd and household size. Some of the specific measures taken include mobility of household units, reduction of herd size during particular seasons, taking up farming and other income generating activities in order to reduce exaggerated reliance on livestock husbandry and herd size. Environmental and ecological factors forced the *Afar* pastoralists to show a steady inclination to agro-pastoralism. Successive governments have also encouraged the process of sedentarisation and agro-pastoralism in the *Afar*. As is the case with other east African herders the *Afar* pastoralists are drawn into the market in order to satisfy some of the basic household economic requirements.

The role of women

Afar women play a central role in the production and household income earning. Besides their contribution to domestic chores (cooking food, fetching water and taking

care of children), they are engaged in milking of small ruminants such as goats, looking after small stock animals in the field, as well as selling of some livestock products such as butter. The construction of the traditional mat house typical of many mobile pastoralists is also the task of women. Nevertheless, despite their role in reproductive and productive activities, women occupy a marginal social status in *Afar* society. It is often the case that *Afar* women do not have full membership rights while their own male children do. For example, women do not have equal rights as their male counterparts with regard to inheritance. They are also less likely to be treated equally before the traditional jurisdiction. Hence they tend to be submissive and timid.

Dagu: An institution of information exchange among the Afar

Modern social services such as telephone facilities are lacking among the *Afar*. An important traditional mechanism that the people use as a replacement for modern communication technology is the *Dagu*. This is a way of information exchange through the relaying of news about important events from one person to another. When two *Afar* people meet, they sit down and spend some time (usually about half an hour or more) discussing the major economic, social and political events that took place recently in their respective localities. This takes place all the time without exception: whether the individuals knew each other previously or not is immaterial. It does not matter if one is in a hurry or not. A stranger who makes his way to *Afar* land is also expected to adopt the system and behave in a similar fashion. Until he gives all the information or news about latest development in his place, he can never be trusted and the *Afar* refrain from effectively interacting with the new comer Figure 1.

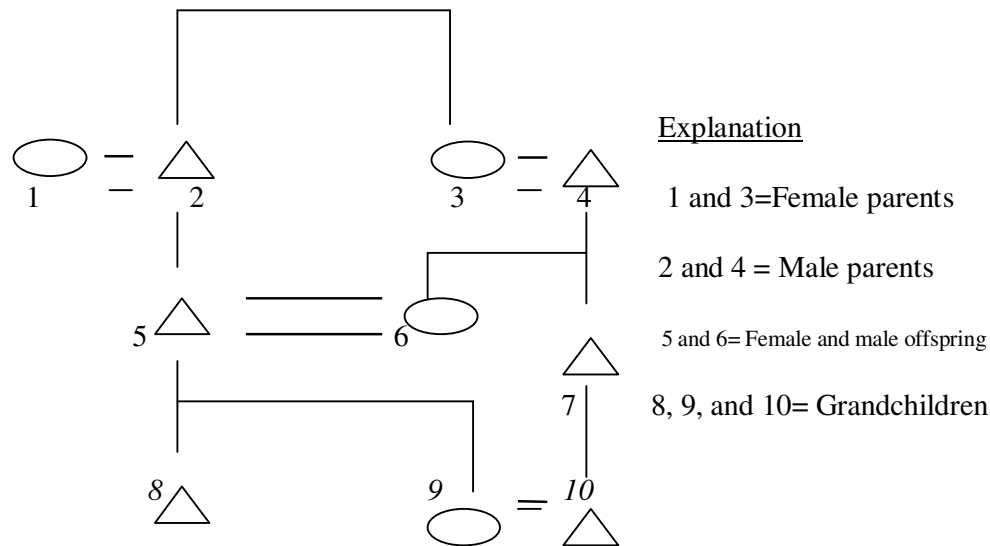

Figure 2. A sketch of cross-cousin marriage in *Afar* (adopted from Getachew, 2001).

Political institutions

Politically the *Afar* are organized on the basis of clanship which is also related to settlement patterns. Members of the same clan tend to live in well defined territories along with their affine. This makes it possible to organize economic and political support in times of crisis. Members of a particular clan have collective responsibilities and moral obligations to help one another during drought and conflict. Failure to cooperate may result in institutionally approved violence and forcible seizure of resources that belong to close kin members.

In times of violent conflict when compensations have to be paid, the compensation money (sometimes in the form of livestock) will be collected from all the clan members of the offender. Without such transfer of money or/and livestock, reconciliation becomes a remote possibility.

The tradition of settling disputes or peace-making is often consolidated with well articulated proverbs and sayings. Table 1 is a list of some of the proverbs often used during dispute processing in a conflict resolution ritual.

The role of clan elders

Age is an important factor in the traditional leadership structure of the *Afar*. Elders not only command resources at the household and community levels but they also shape the behaviour of children and grand children.

Elders have a symbolic authority over younger generations and hence play a significant role in the provision of informal education and disciplining of the young generations. Through fairy tales, proverbs and

stories, elders pass on tradition, folk-culture and wisdom to successive generations.

However, post 1960s developments in the area have resulted in changes to the strength of the customary rules of social relationship and economic exchange, and to the extent to which elders influence the youth. There has been a growing threat to the type of gerontocracy that existed for centuries in *Afar* land. In the past, elders were able to manage and counterbalance the aggressiveness and military orientation of the youth. The adoption of agriculture and urbanized life (together with other factors such as increased vulnerability to livelihood crisis due to drought and famine as well as the influence of highland culture) has created a favourable ground for rather individualistic mentality and less concern for communal tradition. The economic and social support network weakened. The youth now have little regard to customary ways of dealing with things and are defiant to traditional laws and guidelines. Hence rebellious behaviour has increased on a substantial scale. On the extra-local dimension some challenges have started to flourish over the past decades due to the influence of global processes. Today, respect for elders and the traditional hierarchy of authority has been seriously diluted through westernisation. The diffusion of new western values signalled the breakdown of tradition and custom, which had once provided effective mechanisms of social control. These current trends create psychological stress within individuals and societies. Generational conflicts and disagreements, therefore, appear to have become endemic. This phenomenon has had serious repercussions for the basic norms of social and economic cooperation among different groups among the *Afar* and their neighbouring territories.

Table 1. List of Important proverbs in *Afar* and their corresponding English meaning.

Afar local proverbs	Meanings or explanations in English
Rabti Miki Tenemteishi	Let bygones be bygones; let the dead be buried
Cafin Hara Aynuhara Gabatbeta	a burning dry wood causes wet leaves to catch fire too. In the context of a social conflict it means when a single man fails to control his emotions, he plunges his entire kin into chaos so that both the good and the evil are equally adversely affected
Umam Kolbaheni Ekhabana Tayshi	Patience and Perseverance are the rightful avenues to success
Lakmesarreta Lakmesanom Gayla Meli	A sick goat cannot make a sick man recover. This is to emphasize that, animals that are transferred as compensation should be healthy. Providing an injured man with a weak or unhealthy animal as a compensation would be perceived as a sign of contempt and may escalate the conflict further
Tugima Bekal Gebat Kokerebameka tuyargi Beri Gebat Kokereba Me'a	It is safer to attack the son of a wise man than kill a goat of an unwise man. When damage is inflicted, a wise man tends to react more diligently and takes conscious steps to handle the situation. An unwise man, on the contrary rushes into retaliations that fuel up the conflict further.
Kigala Aferayba Wudril Eski Habtiki Komwan	One can never escape along with stolen animals as the footprints will remain behind; (implying that truth always prevails)
Namanti Lenumu Aran Mayabulan	It is stupid to ask a person with two healthy eyes if he can see the sky. This saying is often used in association with witness accounts. A person called upon into a dispute settlement forum as a witness consolidates his account of what happened through rhetoric explanations.
Kena Wenim Kirkirol Megiyan	One who fails to abide by elders' advice falls into a bottomless pit.
Gali Ari-uka Adi Mayako-a	You can never load everything you have on a camel back. This is often used when either or both of the conflicting parties try to press their case by providing a mass of information that creates a state of confusion before the judges. There seems to be a metaphoric link between 'the camel', which is capable of shouldering burdens and 'the elders' who are wise and patient. Implied in the proverb is that although the camel and elders are bestowed with strength, both have their own limitations too.
Yalahmeshi Habeseti	Better to leave all to God. This proverb is useful to maintain the <i>Afar</i> tradition of forgiveness across successive generations.

(Source: Afar Elders in Ab'ala district)

Conclusion

The Afar represents a good example of the many African cultures passing through the turbulence of globalisation while resiliently struggling to maintain their indigenous identities. In the context of Afar,

the institutional change and continuity can be witnessed at various levels. While aspects of the material culture have remained intact for many years despite global pressures, the norms, values and institutions which make up the non-material culture are fast disappearing. *Afar* elders shoulder

the responsibility of maintaining their pastoral traditions through effective informal education in the form of storey telling, oral poetry and proverbs. However, successful transfer of local knowledge and customs to successive generations comes under constant challenge mainly from extra-local

factors. With diffusion of western ideas and technology, the cosmology, views, perceptions and practices of indigenous people has been significantly eroding. Cultural change is always inevitable in every society. Hence, the dilemma for future generations is there fore how to accommodate institutional dynamism within the frame work of indigenous *Afar* identity formation.

REFERENCES

- Central Statistical Authority (2006). The 2004 Population and Housing Census of Ethiopia. Results for *Afar* Region Stat. Report, AdisAbaba, Ethiopia, 9(1): 9-10
- Getachew K (2001). Tradition Continuity and socio-economic Change among the Pastoral *Afar* in Ethiopia, Berghahn Books, Inc
- Markakis J (2004). Ensuring the Sustainability of Pastoralism in East Africa Minority.
- Piquet F (2002). *Afar* Region: A deeper crisis looms Assessment Mission: 10 - 19 October, 2002 UN-Emergencies Unit for Ethiopia
- Yaynshet T, Kelemework T (2004). Indigenous Rangeland Resources and Conflict Management by the Northern *Afar* Pastoral Groups of Ethiopia, the Dry land Coordination Group (DCG) Report, p. 31.