

Full Length Research Paper

Investigation of the properties of self-compacting concrete with palm kernel shell ash as mineral additive

Sylvester O. O. and Lukuman B. I.*

Department of Civil Engineering, University Of Benin, Benin City, Edo State, Nigeria.

Received 13 December, 2017; Accepted 19 February, 2018

This study investigates workability and the compressive strength properties of self-compacting concrete with palm kernel shell ash (PKSA) as mineral additive for partial cement replacement. The iterative method mix design was used, where water and super plasticizer contents were fixed while solid constituents were adjusted for optimum performance. The mixes were to achieve EFNARC's 650 and 800 mm slump-flow limits. The results showed that up to 25% replacement of cement using PKSA produced self-compacting concrete with the workability criteria met and comparable compressive strength.

Key words: Self-compacting concrete, palm kernel shell ash (PKSA), additives, strengths.

INTRODUCTION

In the last few decades, a new innovation was added to the concrete family, high performance concrete, defined as a concrete with high durability due to low water-cement ratio (Gagne et al., 1989).

Self-compacting concrete (SCC) belongs to the group of concrete described as high performance concrete due to its ease of workability (Ouchi et al., 1996). This concrete has in addition to the four constituents of normal concrete: water, cement, fine aggregate and coarse aggregate, additives to improve specific properties of the concrete. These properties relate to their workability and/or strength.

Additives or admixtures are used to alter and improve hardened properties of concrete, they may enhance the durability, workability or strength characteristics of a given concrete mixture. There are many studies on the

use of more common mineral additives such as: rice husk ash (RHA) (Atan and Awang, 2011), fine lime stone powder (Ye et al., 2007; Felekoglu, 2007; Esping, 2008; Topccedil and Uygunoglu, 2010), pulverized-fuel ash (Sukumar et al., 2008; Sahmaran, 2009; Liu, 2010; Siddique, 2011) and silica fume (Yazici, 2008; Turkel and Altuntas, 2009; Gesoglu et al., 2009; Guneyisi et al., 2010).

Palm kernel shell is a waste product in palm oil mills. It is obtained by the extraction of palm oil from the fruit. The waste (palm oil husk and palm kernel shell) is used as fuel in the boiler of palm oil mill. Recent investigation on oil palm kernel shell concrete (OPKSC) gave results which show that palm kernel shell (PKS) can be used to produce concrete of medium and high strength (Johnson et al., 2010).

*Corresponding author. E-mail: lukumanbako@gmail.com.

Table 1. Chemical composition of OPC and PKSA.

Chemical Composition	OPC	PKSA
Silicon (iv) Oxide(SiO ₂)	17.28	42.60
Aluminum Oxide (Al ₂ O ₃)	4.17	2.40
Iron Oxide (Fe ₂ O ₃)	2.24	5.60
Calcium Oxide (CaO)	61.67	4.30
Magnesium Oxide (MgO)	1.05	2.20
Sodium Oxide (Na ₂ O)	0.05	1.30
Potassium Oxide (K ₂ O)	0.42	0.50
sulphur (iv) oxide (SO ₂)	1.68	0.02
Manganese Oxide (MnO)	–	0.03
Phosphorus Oxide (P ₂ O ₅)	–	0.005
Moisture Content	–	0.007
Loss on Ignition	0.03	0.78

Studies have also been carried out with oil palm shell as light weight aggregate in light weight high strength concrete. Payam et al. (2011) and Hossein et al. (2015) investigated the effects of palm oil fuel ash (POFA) on fresh and hardened properties of self-compacting concrete. POFA was employed by Belal et al. (2014), as partial cement replacement in producing durable self-compacting high strength concrete, Oti et al. (2015) showed that PKS and PKSA can be used for the production of high strength compacting concrete. The employment of additives in SCC was also found to produce other benefits like maximizing SCC properties, reuse of industrial and agricultural waste in concrete production.

Self-compacting concrete (SCC) are improved concrete mixtures derived by adding appropriate measures of super plasticizers and viscosity modifying agent (VMA). Compaction is the process of removing air from fresh concrete and increasing the density of concrete by reducing the spaces between the particles. The self-compacting concrete (SCC) as the name implies, is a concrete which does not have any need for external vibration during placing, able to flow under gravity filling form work and achieving a very high level of compaction.

MATERIALS AND METHODS

Cement

Grade 42.5 ordinary Portland cement (OPC), manufactured by Dangote Cement Company was used in this study. Its chemical composition is presented in Table 1.

Palm kernel shell ash (PKSA)

Palm kernel shell ash used was obtained locally and incinerated at about 420°C in an oven chamber and grinded to powder passing through 0.150 mm sieve (EFNARC 2002, section 4.10). The chemical compositions are provided in Table 1.

Table 2. Sieve analysis for aggregates.

BS size (mm)	Passing (%)	
	Coarse aggregate	Fine aggregate
10.00	89.2	-
5.00	87.4	-
3.35	68.4	57.6
2.36	46.9	51.7
2.00	33.2	39.3
1.18	18.7	23.5
0.60	7.9	11.6
0.30	-	7.3
0.21	-	4.8
0.15	-	1.2
Pan	0	0

Super plasticizer

The super plasticizer used is the MAPEI FLUID N100 KSA (high range water reducing super plasticizer for high strength ready mixed concrete in hot climate) used for improving the workability of concrete. It is a highly effective liquid based super plasticizer for the production of free flowing concrete that complies with the requirements of BS 5075.

Water

The water used in this study was tap water free from impurities.

Coarse aggregate

The coarse aggregate used was 10-5 mm crushed granite stone of BS: 812-103.2-1989 with a specific gravity of 2.66 in SSD. Both aggregates were sieved as illustrated in Table 2.

Fine aggregate

The fine aggregate used in the experiment were clean natural sand with specific gravity of 2.61 and fineness modulus of 2.76, maximum size not more than 3.35 mm.

Experimental works

Steel mould of 150 × 150 mm was employed in the preparation of the concrete specimen for compressive strength determination. In ascertaining the fresh properties, the slump flow, slump flow time (T50), L-box test and V funnel test (segregation resistance test) were performed in accordance with EFNARC (2002) guidelines. These tests were conducted so that the concrete in its fresh state fulfill the criteria for self-compacting concrete which are passing ability, filling ability and segregation resistance. The procedure of the tests is as follows:

First, sand and gravel with one-third of the water were put into the mixer. Thereafter, cement (pozzolanic materials), palm kernel shell ash with other third of the water were added. Then, the remaining water and plasticizer were added to the mix. Mixing carried was out

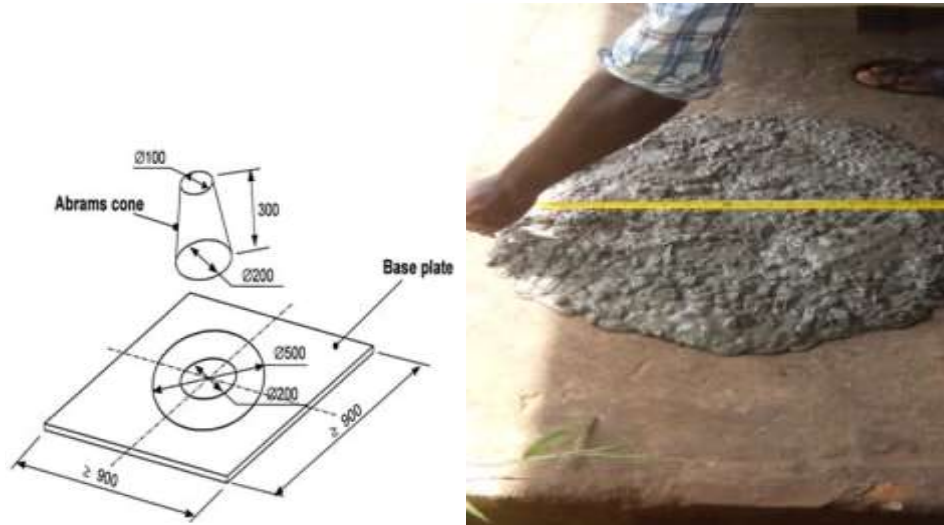

Figure 1. Slump flow test using Abrams cone.

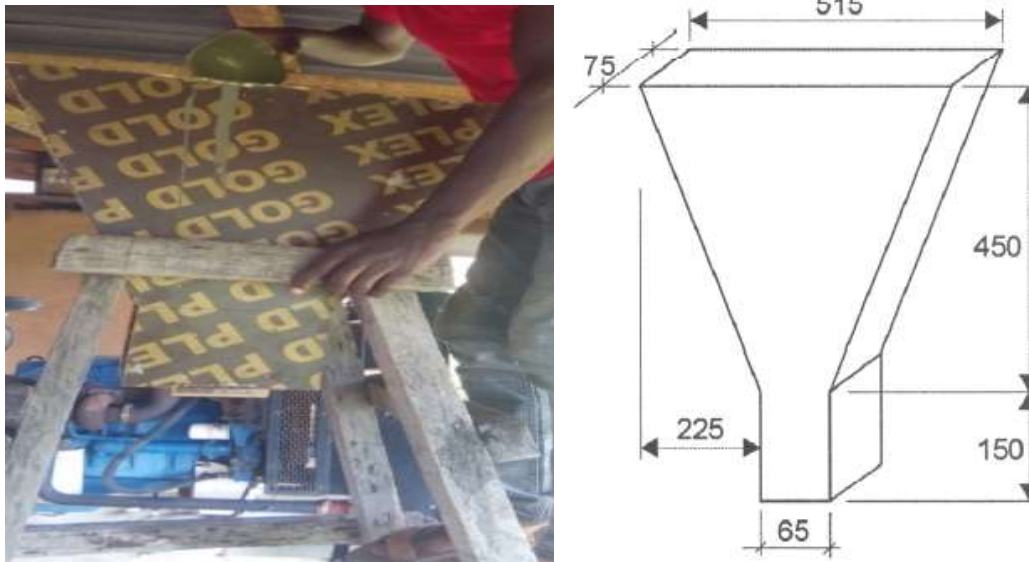

Figure 2. V funnel test apparatus.

for about 2 to 3 min, and then the process was stopped for 3 min. Then, the mixture was mixed for 2 min so that a thorough mix can be obtained. The self-compacting concrete (SCC) mixes of various percentage of palm kernel shell ash (PKSA) were determined by replacement of cement by palm kernel shell ash by conducting slump flow, L Box and V Funnel tests.

Workability

The slump flow test method

The slump flow assesses the flow of self-compacting concrete (SCC) under gravity in the absence of obstruction. It was developed in Japan in 1992 (JSCE, 1992) for use in underwater concrete. It is

based on the method used in determining slump. As shown in figure 1, it involves the filling of the Abrams cone with the self-compacting concrete without compacting and after a time lifting cone. The average of two perpendicular diameters were used in determining the slump. The T50 time which measures the time in seconds taken for the horizontal flow of concrete to reach 500mm diameter mark.

V funnel and V funnel (5 min) test

The V-funnel test involves the determination of the filling ability of the concrete. It is conducted with a maximum of 20 mm aggregate size. A V-funnel as shown in figure 2 is filled with about 12 L of concrete, with the bottom lock in place and thereafter, the time for a

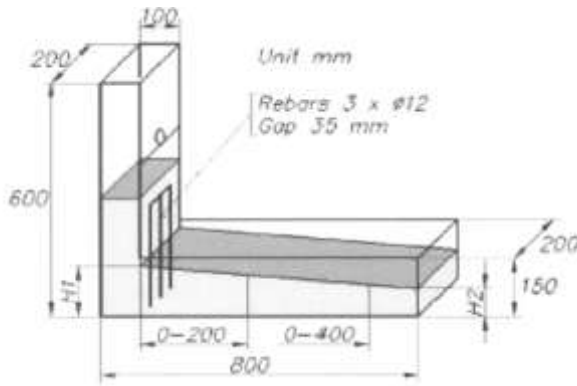

Figure 3. L Box test apparatus.



Figure 4. Compressive strength test machine.

concrete to go through the test set up is measured. According to EFNARC (2012), if the concrete shows segregation, there will be increase in the flow time.

L box test method

This test as described by Petersson et al. (2002), is used to access the extent to which the concrete can flow when obstructed by reinforcements. It involves the pouring in of concrete into the vertical member with the bottom end closed and when it has settled, the gate is removed and thereafter the height difference of the two ends of the horizontal member H_1 and H_2 is checked. H_2/H_1

gives the blocking ratio. The test set up is illustrated in figure 3.

Tests on hardened self-compacting concrete (SCC)

The compressive strength properties of self-compacting concrete (SCC) mixes are obtained by cube specimen (150 mm x 150 mm x 150 mm). Six cube specimens for each percentage replacement palm kernel shell ash (PKSA) (5, 10, 15, 20 and 25%) were crushed to determine the 7, 14, 21 and 28 days crushing strength using a 3000kN compression testing machine shown in figure 4. The compressive strength test on cubes is conducted as per standards, that is, the cubes are exposed on the first day and subsequently

Table 3. Self-compacting concrete combination

Mix	Cement (KG)	Fine aggregate (KG)	Coarse aggregate (KG)	WATER (KG)	PKSA (KG)	Water powder ratio	MAPEI fluid N100 KSA
CC	20.20	31.4	43.1	7.65		0.35	
SCC 1	20.4	31.4	43.1	7.65	2.9	0.35	2%
SCC 2	19.37	31.4	43.1	7.65	4.1	0.35	2%
SCC 3	18	31.4	43.1	7.65	6.42	0.35	2%
SCC 4	16.1	31.4	43.1	7.65	7.78	0.35	2%
SCC 5	14.19	31.4	43.1	7.65	10.85	0.35	2%

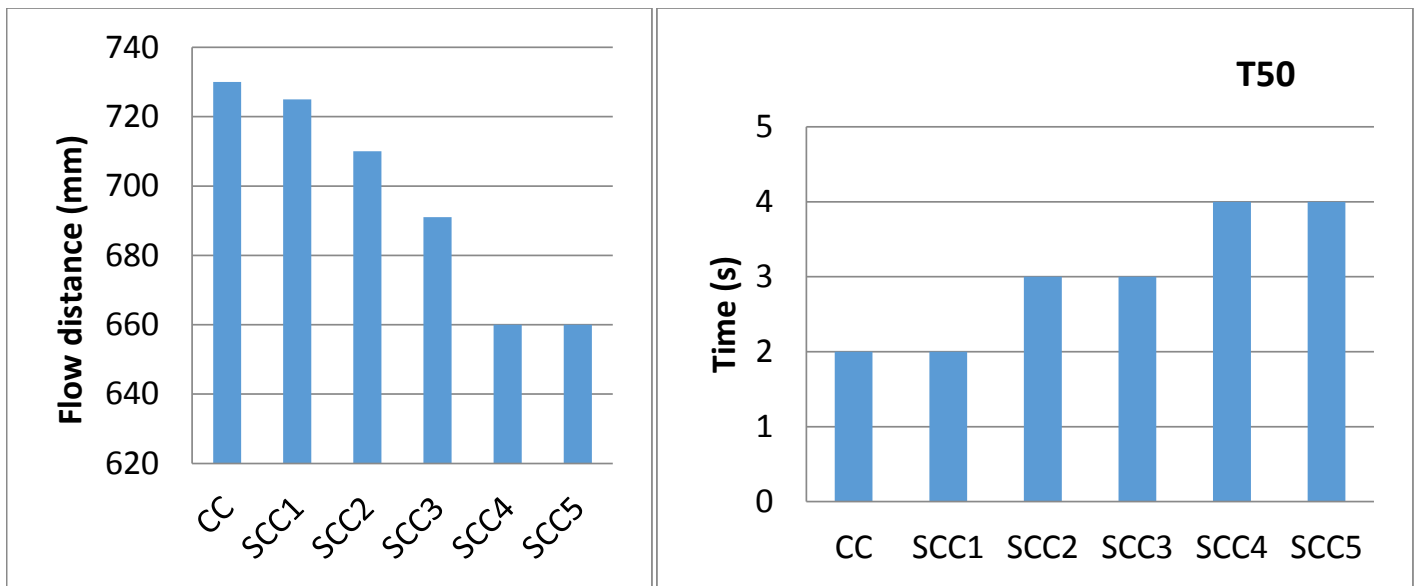
**Chart 1.** Slump flow test result charts.

placed in the curing tank for the rest of the time before crushing.

RESULTS AND DISCUSSION

After a rigorous iteration process, the design mix in table 3 was arrived at which was able to fulfill EFNARC's criteria for passing ability, filling ability and segregation resistance

Slump flow test

Based on the scientific evaluation, the slump flow test was used for determination of the concrete consistency. After the slump cone is lifted, the average of two perpendicular diameters is used to determine the slump. The T50 time which measures the time in seconds is taken for the horizontal flow of concrete to reach 500 mm diameter mark. The Chart 1 shows that the values decreased with increasing PKSA content and the time for

T50 increased in the direct proportion to the PKSA content.

V funnel test and V 5 min test

The designed mixes, CC, SCC1, SCC2, SCC3, SCC4 and SCC5 were found to give satisfactory V funnel and V 5 min results as depicted in Chart 2.

L Box test

The ability of the concrete to pass through high congestion as applicable in heavily reinforced sections was tested and the results are presented in Chart 3. The blocking ratio which is the ratio of the horizontal height the concrete reaches in both ends of the horizontal member after the gate is opened, shows a decrease with increasing PKSA content.

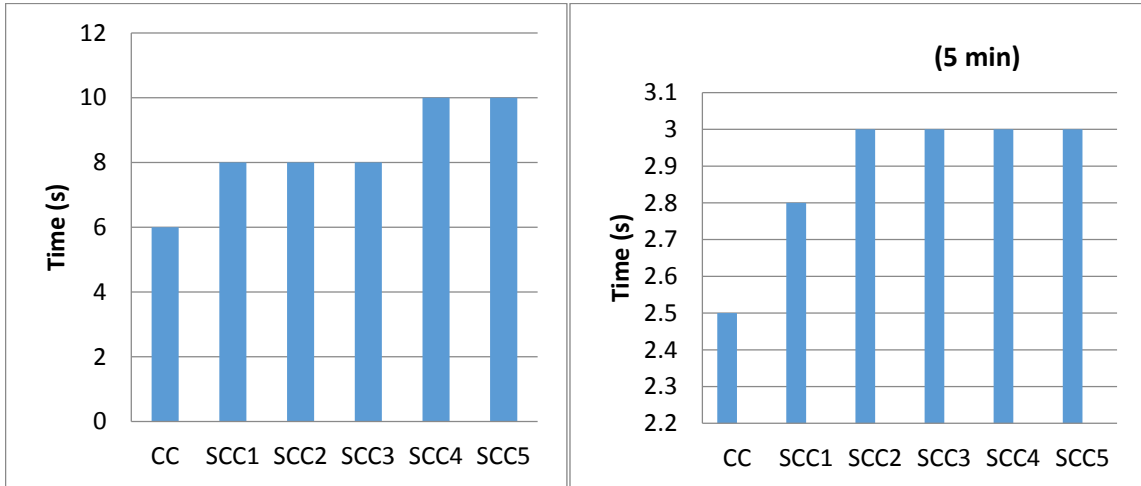

Chart 2. V funnel test result charts.

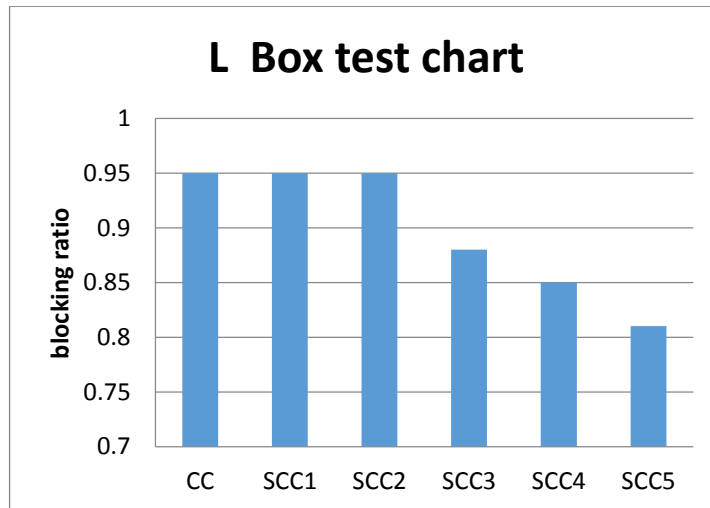

Chart 3. L box test result.

An EU research team suggested 0.8. T_{20} and T_{40} times of minimum value indicate the ease at which the concrete flows. These values however have not been unanimously agreed upon. Any blockage by coarse aggregate behind the reinforcing bars can be seen easily.

Tests on hardened self-compacting concrete (SCC)

The compressive strength development indicates the increases of strength with the increase in curing age probably due to the continuous hydration of cement. However, the increased replacement of cement with PKSA leads to reduction in compressive strength as compared to the control specimen. This agrees with findings of Xie et al. (2002) and Siddique (2011) that worked on fly ash as mineral additive and found out that

the compressive strength decreased with increase in the percentage of cement replacement with fly ash.

Conclusion and recommendation

The fresh state properties of SCC which are the filling ability, passing ability, resistance to segregation for the designed mixes with various percentage of replacement of cement by PKSA, were determined by slump flow, V-funnel at T 5 min and L Box tests. Results indicate that with increase in the PKSA quantity in the design mix, there is decrease in the workability for all mixes with PKSA. That is, there is an inverse relationship between the PKSA and the workability. Self-compactibility was retained for 5, 10, 15, 20 and 25% of palm kernel shell ash (PKSA) replacing cement in self-compacting

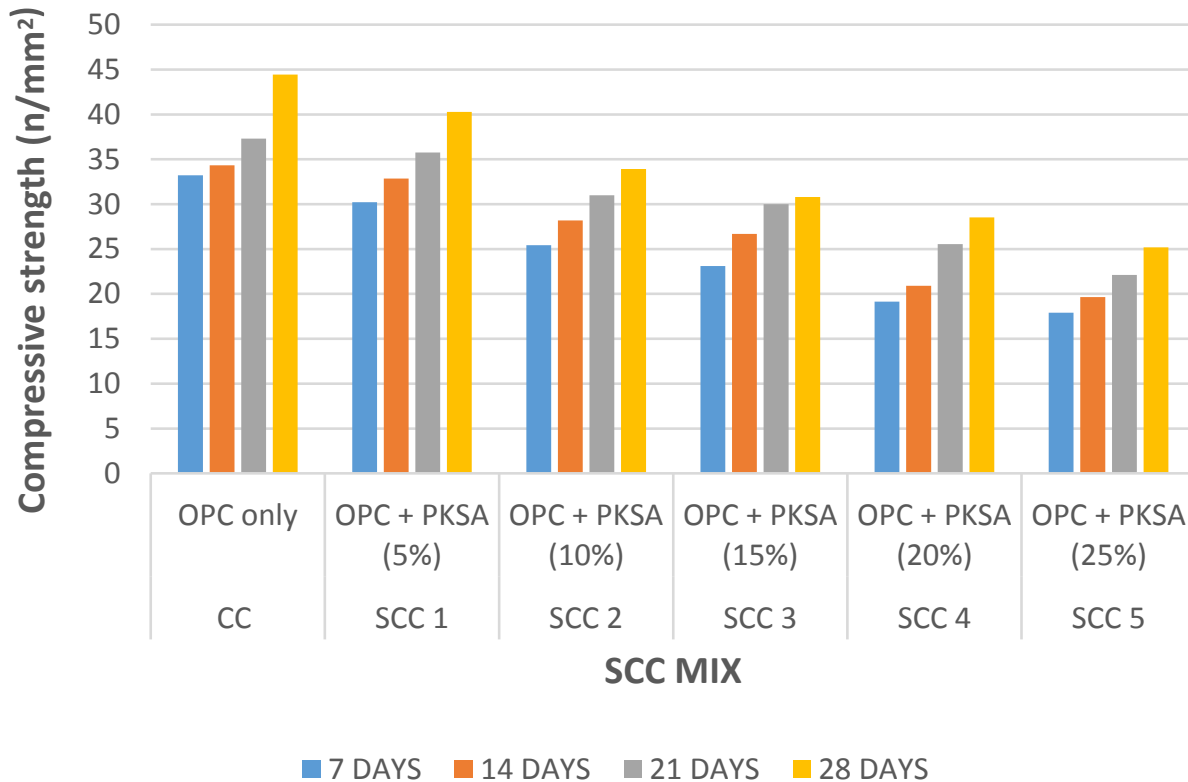

Chart 4. Compressive strength test result.

concrete (SCC) as shown in Chart 4.

Hardened property of cube casted is the compressive strength in this case. The self-compacting concrete (SCC) mixes with the aforementioned percentages of replacement of cement by PKSA were studied.

1. The workability of studied mixes (CC, SCC 1, SCC 2, SCC 3, SCC 4 and SCC 5) were found to meet EFNARC (2002) criteria for self-compacting concrete. The diameter of the slump flow was greater than or equal to 0.5 m, the blocking ratio in all cases was a minimum of 0.80 and flow times of 6 to 12 s were observed on the fresh self-compacting concrete (SCC) mixes.
2. From the charts and empirical results obtained, it can be seen that all the studied mixes (CC, SCC 1, SCC 2, SCC 3, SCC 4, SCC 5) all have their compressive strengths increased with time. There is reduction in strength though with increase in PKSA content.
3. The smaller size aggregates gave better workability. It was observed that with smaller aggregates, better results were obtained in the fresh state.
4. SCC mixes were determined by conducting laboratory experimental trials. These were done in accordance with the systematic procedures brought about by EFNARC and other researchers.
5. The characteristic SCC mixes is composed of high

powder content, efficiently maximizing water/powder ratio, more quantity of fine aggregate in comparison with coarse aggregate.

6. SCC can be obtained for different PKSA contents or cement contents as long as the paste volume constituted by the water cement ratio is kept constant.
7. The use of viable quality super plasticizer is a prerequisite to obtain SCC mix of desired workability.

CONFLICT OF INTERESTS

The authors have not declared any conflict of interests.

REFERENCES

- Atan MN, Awang H (2011). The compressive and flexural strengths of self-compacting concrete using raw rice husk ash. *J. Eng. Sci. Technol.* 6(6):720-732.
- EFNARC (European Federation Of National Trade Associations Representing Producers And Applicators Of Specialist Building Products) (2002). *Specification And Guidelines For Self-Compacting Concrete*, February 2002. Hampshire, U.K.
- Esping O (2008). Effect Of Limestone Filler BET (H₂O)-Area On The Fresh and Hardened Properties Of Self-Compacting Concrete. *Cem. Concr. Res.* 38:938-944.
- Felekoglu B (2007). Utilisation Of High Volumes Of Limestone Quarry Wastes In Concrete Industry (Self-Compacting Concrete Case).

- Resour. Conserv. Recycling 51:770-791.
- Gagne R, Pigeon M, Aitin PC (1989). Diecer Salt Scaling Resistance of High Performance Concrete' Paul Kieger Symposium of Performance Concrete. SP – 122 ACI.
- Gesoglu M, Guneyisi E, Ozbay E (2009). Properties Of Self Compacting Concretes Made With Binary, Ternary, And Quaternary Cementitious Blends Of Fly Ash, Blast Furnace Slag, And Silica Fume. *Constr. Build. Mater.* 23(5):1847-1854.
- Guneyisi E, Gesoglu M, Ozbay E (2010). Strength And Drying Shrinkage Properties of Self-Compacting Concrete Incorporating Multi-System Blended Mineral Admixtures. *Constr. Build. Mater.* 24(10):1878-1887.
- Japan Society of Civil Engineers (JSCE) (1992). Recommendations for Design and Construction of Anti-washout Underwater Concrete. *Concrete Library of JSCE.* 19:89.
- Liu M (2010). Self-Compacting concrete with different levels of pulverized fuel ash. *Constr. Build. Mater.* 24(7):1245-1252.
- Ouchi M, Hibino M, Okamura H (1996). Effect of superplasticizer on self - compactability of fresh concrete. *J. Transp. Res. Board* (1574):37-40.
- Petterson O, Gibbs J, Bartos P (2002). Testing-SCC Proceedings of the First North American Conference on the Design and Use of Self-Consolidating Concrete. Centre for Advanced Cement Based Materials, North Western University, Chicago. pp. 253-258.
- Sahmaran M (2009). Transport and Mechanical Properties Of Self Consolidating Concrete With High Volume Fly Ash. *Cem. Concr. Compos.* 31:99-106.
- Siddique R (2011). Properties of Self-Compacting Concrete Containing Class F Fly Ash. *Mater. Design* 32:1502-1507.
- Sukumar B, Nagamani M, and Raghavan R (2008). Evaluation of Strength at Early Ages of Self-Compacting Concrete with High Volume Fly Ash. *Constr. Build. Mater.* 22(7):1394-1401.
- Topccedil B, Uygunoglu T (2010). Influence of mineral additive type on slump-flow and yield stress of self-consolidating mortar. *Sci. Res. Essays* 5(12):1492-1500.
- Turkel S, Altuntas Y (2009). The Effect of Limestone Powder, Fly Ash and Silica Fume on the Properties of Self-Compacting Repair Mortars. *Sadhana* 34(2):331-343.
- Yazici H (2008). The Effect of Silica Fume and High-Volume Class C Fly Ash on Mechanical Properties, Chloride Penetration and Freeze–Thaw Resistance of Self Compacting Concrete. *Constr. Build. Mater.* 22(4):456-462.
- Ye G, Liu X, De Schutter G, Poppe A, Taerwe L (2007). Influence of limestone powder used as filler in SCC on hydration and microstructure of cement pastes. *Cem. Concr. Compos.* 29:94-102.
- Johnson A, Hilmi M, Mohd ZJ (2010) Comparison of mechanical and bond properties of oil palm kernel shell concrete with normal weight concrete. *Int. J. Phys. Sci.* 5(8):1231-1239.
- Payam S, Mohd ZJ, Hilmi M (2011). Oil palm shell as a lightweight aggregate for production high strength lightweight concrete. *Const. Build. Mater.* 25:1848-1853.
- Oti JE, Kinuthia JM, Robinson R, Davies P (2015). The use of palm kernel shell and ash for concrete production. *Int. J. Civil, Environ. Structural, Construction Architectural Eng.* 9(3):263-270.
- Hossein MH, Abdul AASM, Abdul HE (2015). Influence of palm oil fuel ash on fresh and mechanical properties of self-compacting concretely. *Sadhana* 40(6):1989-1999.
- Belal A, Payam S, Mohd ZJ, Johnson UA (2014). Palm oil fuel ash as a partial cement replacement for producing durable self-consolidating high-strength concrete. *Arab. J. Sci. Eng.* 39(12):8507-8516.
- Xie Y, Liu B, Yin J, Zhou S (2002). Optimum mix parameter of high strength self compacting concrete with ultra pulverized fly ash. *Cem. Concr. Res.* 32(3):477-480.