

Review

The celestial factor

P. C. van den Noort^{1*} and A. M. T. Elewa²

¹Wageningen University, Netherlands.

²Geology Department, Minia University 61519 Egypt.

Accepted 18 October, 2011

In reality there are various kinds of explanations for each type of extinction. This paper introduces a new theory to explain and to estimate the size and frequency of all extinctions over the entire period of 600 my of the fossil record. The central point was the search for a common pattern and even one common formula. The explanation seemed to be excellent. We will demonstrate in what way death is a fact of life: by making calculations with the new formula: there is a constant margin of 10 pct, and about seven peaks with at least 25 pct of extinction victims. Those peaks occur each 85 million years, but their frequency has increased over time. In principle, the predictability of the next peak is limited, because of chaos (within the solar system and the ecosystem on Earth), the unpredictability of mutations in Nature, of innovations by Man, and let alone the disastrous impacts of asteroids. It also depends on the concept of whether life is cyclical or linear. Therefore, some predictions have a low likelihood of occurrence. In the traditional theory or old vision there are many extinctions and even mass extinctions, each with various theories believed to be their cause. There is no single theory explaining all extinctions. Man was witness to and perhaps later on even guilty of extinctions. Even as early as in the ice ages he tried to find facts and continued later on in the age of science. But we still do not see extinctions in their right perspective, and it would be very useful to change this. The right perspective depends on the modern vision on the structure of the world that is in the chaotic solar system, with changing orbits of the planets.

Key words: Extinction, mutation, chaos, ecology, evolution, falsification, prediction, catastrophe, radiation, asteroid, foraminifers, formula, orbit, Venus, Mars, Earth, volcanism.

INTRODUCTION:

A new perspective

We may say that there are many factors behind the increases and decreases of the number of species. We will try to bring them together in a simple diagram (Figure 1). The main causes are as follows:

1. Chaos in the solar system and changes in the position of the axis of the Globe, both causing changes in the radiation on the surface of Earth,
2. Climate,
3. Volcanism,

4. Tectonics, with changes of the surface of the Earth,
5. Impacts (I) of asteroids, with often catastrophic effects.

All the five factors are in a very complicated relationship. We see the influence of many factors on extinctions (L) and on the number of species (N), or on the numbers of mutations (M). Mutation (M) does increase the number of species (N). Increasing the number of species leads to more competition and, as a consequence, some species will become extinct. This is called extinction by natural selection. Mutation also plays a very different role in the growth process of an ecosystem and subsequently on extinctions. If there are sufficient mutations the growth is stable (Figure 2). What is established is similar to an ecological hierarchy, with the highest developed species of the particular period placed on top. If the mutations fall back something remarkable happens: the Hierarchy

*Corresponding author. E-mail: noort1935@hotmail.com or ashrafelewa@gmail.com.

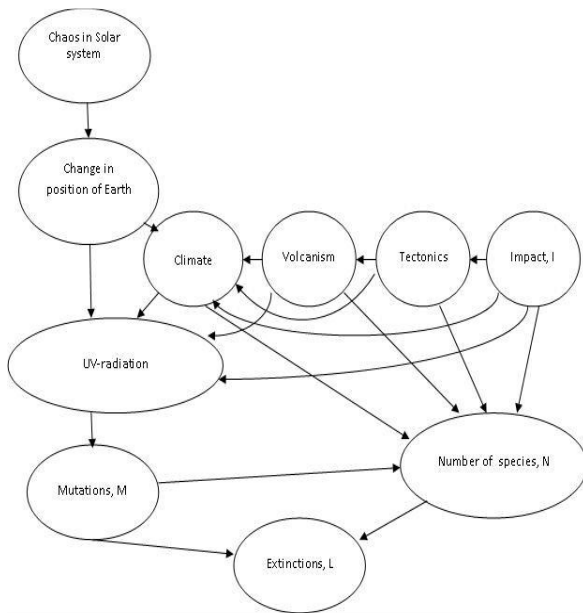

Figure 1. Diagram on causes and effects on extinction.

we could say:

$$L = f(N, M, I)$$

This model leads to a simple equation for testing purposes:

$$L = aN + bM + cI + u$$

where 'u' is a statistical rest term.

There are some variations on this formula by using dM instead of M and a case of interaction between impact and mutation. If Earth is far from the sun, it is close to the asteroid belt. Thus, L could increase by impacts, but the radiation of the sun there is also lower and causes fewer mutations, which may also increase L . The two factors then act together, and we could regard this as an interaction by using the third term ($dM.I$) instead of I alone. In total we have six possible equations. It is remarkable that for evolution we could not formulate such a simple equation because it has not the "at the end of the line"- position as Extinction has, in Figure.1.

Falsification

It is beneficial to commence with an illustration by words only, and for only two species. We use the foraminifers in Egypt as an example. There were two species: A and B. In the situation of Figure 2 we notice that type A is a rather marginal animal, therefore positioned at the bottom of the Hierarchy. The larger, more productive type B has just about reached its position at the top. The difference between the two is related to mutations M and with the journey of A and B along the side of the ecological hierarchy - this is natural selection; the struggle between species (N).

Subsequently, a change in conditions occurred (Figure 3) and the mutations fell back. As a consequence (from Chaos-Theory) the more dominant variant has moved down the Hierarchy, but nothing happened to the marginal types. What we see here is similar to a revolution: the highest fell down and the lowest remained in position. We know that 65 my ago, considerable damage to the fauna occurred due to the impact of an asteroid (I). What might we expect to find after such an occurrence? Below the boundary we should see type A and B - and B is dominating. Above the boundary we will see only type A; B must have become extinct. This is also the case under and above the dark boundary in Figure 6.

In this simple example we may notice also an interesting extinction (also dated 65 my ago), because under the dark line we see simple species (comparable with A) and also ammonites (comparable with B) but above the dark line we see no ammonites anymore. Both examples indicate no contradiction to the theory, but they are no real falsification or test.

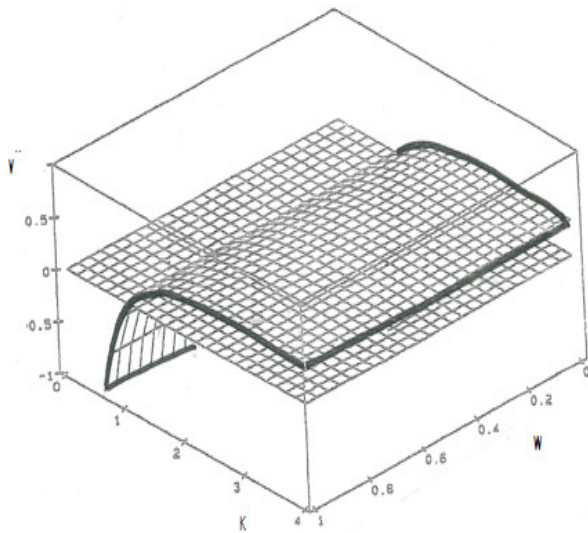

Figure 2. The Stable Ecological Hierarchy in case of increasing mutations; V =vitality, k =coefficient of growth, w =degree of competition; $w=0$ =monopoly, $w=1$ =pure competition (Noort, 1995).

deteriorates, especially from the top (Figure 3). The highest developed species disappear forever, and show a special form of extinction (Noort, 1995). This idea was based on the chaos theory, in the early nineties not yet accepted as a useful theory like it is today (Bennett, 2010). If we look at the diagram closely, the relations at the "bottom" of the scheme appear not that complicated -

Table 1. Statistical results: six equations, their coefficients, the standard errors and correlation coefficients. The t-test requires that the coefficients are at least 2 x their standard errors.

Variable	Equation					
	(1)	(1a)	(2)	(2a)	(3)	(3b)
N	0.076 (0.035)	0.057 (0.054)	0.079 (0.036)	0.230 (0.057)	0.184 (0.049)	0.220 (0.044)
M	0.120 (0.073)	0.071 (0.148)				
ΔM			0.423 (1.23)			
ΔM^a				0.427 (0.185)	0.433 (0.149)	-0.166 (0.283)
I	53.74 (13.89)	47.36 (19.54)	53.03 (14.84)		40.31 (14.26)	62.14 (15.25)
$\Delta M I$						0.763 (0.322)
M I		0.021 (0.191)				
R-square	0.59	0.57	0.60	0.56	0.74	0.83
Degrees of freedom	24	24	23	13	12	11

^{a)} $\Delta M < 0$ only.

Table 2. The meaning of the various values of the correlation coefficients.

R	Rsquare	Explained (%)	Interpretive power
<0.3	<0.1	<10	Very weak
0.3 to -0.5	0.1 to -0.25	10 – 25	Weak
0.5 to -0.7	0.25 to -0.5	25 – 50	Rather weak
0.7 to -0.85	0.5 to -0.75	50 – 75	Strong
0.85 to -0.95	0.75 to -0.9	75 – 80	Very strong

The meaning of the various values of the correlation coefficients.

Statistical tests

We have seen that there are various hypotheses. Yet how can we discriminate amongst them? The philosopher Karl Popper proved that the only direction to take was falsification. Very good possibilities were e.g. regression and correlation analysis or tests. The tests are all based on statistical data. We will test our six linear regressions equations. The test must provide answers, e.g. do

the coefficients a, b, and c have the right sign and are they statistically different from zero; and also whether the correlation coefficient is high enough to justify an explanatory case?

The results of statistical testing are in Table 1. Each of the six columns is such a regression-equation with an estimate of the regression coefficients and their standard error, between brackets (). In order to be statistically significant the coefficient must at least be two times larger

than the error, according to the well known t-test.

This is indeed the case for all equations, and in addition they have the expected sign. The measure of explanation is R square; providing the percentages of explanation. The measure of relationship is given by the correlation coefficient. This one is high, given the degrees of freedom. The statistical Table 2 indicates a high interpretive character of the presented model of extinctions. The presented idea of a general explanation

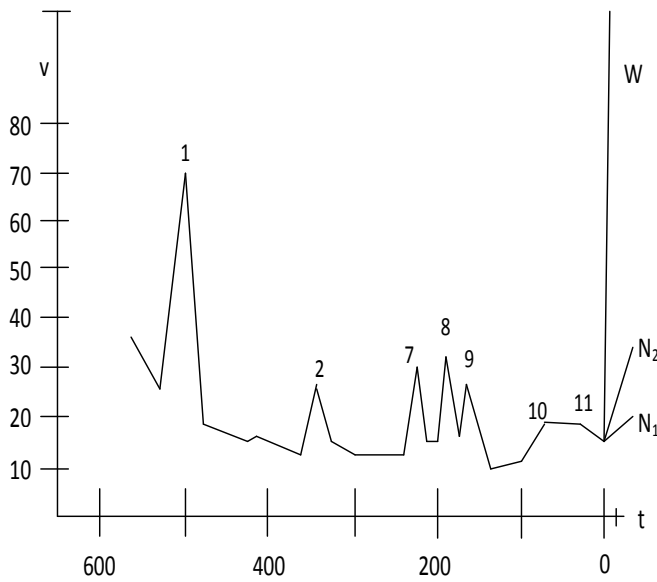

Figure 4. Estimates of extinctions in (in %) the last 600 my and two predictions of the next mass extinction.

is not in contradiction with facts, because the coefficients have the expected sign and differ statistically from zero indeed. The correlation coefficient is high. Therefore we can justify a statistical acceptable relationship, based on the process of falsification.

Forward and backward predictions

The statistical formula can now be used for estimating the size of extinctions over the whole period of 600 million years (Figure 4). These estimates can be named backward predictions. We see that there is no basis for the concept that the number of species did not change over time (Jacobs, 2002), because there is a continuous margin of extinctions (about 10 pct) and 7 peaks of at least 25 pct. of victims. The frequency of the Peaks was, on average, one in 85 million years, but the frequency increased gradually over time. The longer the period between peaks (t), the more families and species may grow and arrive in the higher developed stage in which they are sensitive for decreasing numbers of mutations. Based on Figure 4 we have found a weak relationship between v and t:

$$v = 3.01 + 0.13t$$

t = 0 my, v = 22pct; t = 45 my, v = 31pct; t = 90 my, v = 40pct.

One of the persistent problems in the evolutionary theory

consists of the missing links. People have an idea of a continuous trend in evolution, with *Homo sapiens* at the top. As a consequence they are unsuccessfully looking for the links between the successive dominant types. Even Darwin made that point, yet he should not have been so concerned. At the end of a period the Ecological Hierarchy caves in and many dominant species disappear forever, the marginal types take their places and some of them become the dominant types in the following period. So there is no special link between the successive dominants, and this holds true for all peaks. We see that there is not only evolution, but also revolution. Revolution prevents any link between the dominant types of the various periods; this is also found during many types of research. Missing links of this type form additional proof for our theory.

It is also repeated continuously that the strongest always wins in evolution (Jacobs, 2002). This is not true. The productive type is the winner of each period between two peaks. It is the type with the highest growth coefficient (k) that will belong to the top region of the Hierarchy. Furthermore it is clear that the dominants do not live forever as a species; no one survived up to these days; not even the Methusalae (a term introduced by Ward for species like stromatolites), living almost without competition (Figures 2 and 3 with w=0). There is no continuous line for the History of Life, but only an upward tendency through a 'zigzag line'.

There are now two forward predictions of the next future peak: (1) Ward estimated an imminent extinction which will bring life to a halt. He implicitly sees life as linear, see W in Figure 4 (2) Noort predicted by extrapolation of the found statistical relationship, using the expected number of years for a peak to occur. This is now somewhat less than 85 years (say 60 my) and the peak may either be somewhat higher than the lowest up to now, or somewhat lower than the highest up to now. See N1 and N2 in Figure 4. A good 'guestimate' is the average of both. Therefore, in about 60 my after peak number 11 we could have the next one with about 35% of victims. Life here is considered cyclical: life changes all the time, but it does not disappear forever.

The difference between the two estimates is considerable. For W we have the shortest period ever and also the highest 'victims rate'. It is possible that the period is much shorter than for its 'rival estimate' and also that its victims rate is much higher, but the likelihood of occurrence is then lower as well.

The constant margin of 10% seems to be an average of all the periods in this frame; and the peaks (v) become higher as the period (t) becomes longer than the average. A short period with a high victims rate does not appear to have a very high likelihood of occurrence.

It is possible to see all extinctions in one perspective or common pattern with the aid of a common formula. We can falsify the many hypotheses. In principle the equations

can also be used for predictions, the backward predictions are excellent, but the predictions for our future have strong natural limitations. Time and size of the next extinction is not possible to estimate, the impressive prediction W has a lower likelihood of occurrence than the guestimate N.

The structure of the world

History shows us several concepts of the structure of the world. The oldest is an idea of the Greek philosophers: the Earth is the centre and the Sun and planets move in perfect orbits, circles, around it. Later it was thought that those heavily bodies were moved by angles. There was also a Tree of Life, the axis of the world, along which creatures of the invisible world could visit and take leave of the Earth (Hardison, 1989).

After that came the age of science in which the position and movement of the Earth and the Sun where interchanged, leaving us with a Solar system, with the Sun in the centre and the planets moving around it, not in circles, but ellipses. Exactly described and measured by some of God's Philosophers (Hannam, 2009) e.g. Copernicus (1473, 1543) and Kepler (1573, 1630).

Newton (1642, 1727) gave the perfect mathematical formulation, using gravity instead of angles. Viewed with a chaotic eye, however, the picture looks subtly different (Hall, 1991). We know that, in principle, his system was not stable as we were taught in school. There is instability or chaos in the solar system (Peterson, 1993). The planets can get wider or narrower orbits, or varying distances, to the Sun. So we are now far away from the eternal order of the old philosophers. This chaotic movement can be simulated by computer programs (Pleitgen and Richter, 1986) but also by a more direct method.

Consequences

The very long term changes in the distance from the Sun have consequences for the melted core of the Earth, for the level and stream of melted material. If Earth makes a chaotic move towards the sun we may expect high tide of lava or "upwellings of magma" and volcanism on a large scale, as described by Coffin and Endholm (1993). In the last 150 my we had five of such periods. For a chaotic movement in the opposite direction we may expect low tide of lava. All this depends on the changing distances towards the Sun, just as in case of ocean water.

In the old models the number of species was stable at the level of the last day of Creation. In reality the number changes over time because of evolution and extinction. The changing orbit of the Earth now has consequences in this field as well, because that distance has influence on

the quantity of UV radiation that will reach the surface of the Earth, and which causes mutations.

In moving away from the Sun the Earth will pass a "critical distance line" after which almost no UV radiation will reach the surface and we will see not many mutations. The opposite will hold if Earth moves in the opposite direction. All this must have consequences for the ecosystems, especially for the 'vitality' of species as can be shown with the vitality-index (also called Newell-index):

$$N = \frac{hw(k-1)(2.6-k) + (1-hw)\log k}{k}$$

where: N = index of vitality of species, k = growth coefficient (between 1 and 4), w = degree of competition and h = mutations.

We can distinguish two situations for h:

h = 0, in a situation of many or increasing mutations (Figure 2).

h = 1, in a situation of few or decreasing mutations, (Figure 3).

Close to the Sun we may expect the situation of Figure 2 and far from the Sun the situation of Figure 3 (Noort, 1995). There are two areas in which the Earth will move. The borderline between the two is very important. In the movement away from the Sun the line indicates the starting point of extinctions and reversed that line will indicate the start of evolution.

The high developed species will find their exit starting about this line and the new mutants will appear also starting about this line. This line comes instead of the tree of Life but is less poetic. The only exceptions are the so called living fossils, who can survive because lack of competition (w = 0).

The relationship between Heaven and Earth or the celestial factor

In Figure 5 we have combined the two types of consequences of the chaotic movement of Earth. If Earth passes the critical line away from the Sun we will have a start of additional extinctions. If Earth makes chaotic turns towards the Sun we will notice upwellings and mass volcanism (Courtillot, 1990). The upper turning points constitute a dramatic situation because of the nearness of the asteroid belt and therefore a higher chance of a hit or impact (Alvarez, 1990). The lower turning points must be quite different, because far away from the asteroid belt (fewer impacts) and near the sun with many mutations.

Not surprisingly, upwellings will not always be followed by extinctions. It depends on the sphere in which the Earth is moving (perhaps we may say that volcanism is

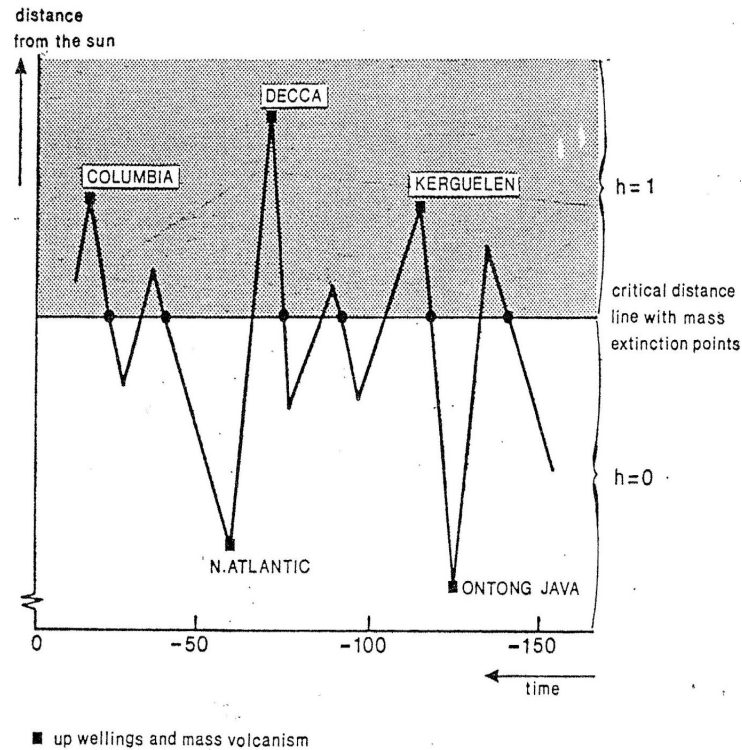

Figure 5. Orbit of planet Earth. This planet moves in a light and in a dark sphere in this picture. The borderline between the two is the critical line. In the light sphere we will see evolution, and in the dark sphere mass extinction. In both spheres there are victims of natural selection. We may expect that in some extreme cases Mars lost all life when Earth was in the extreme dark area and Venus lost life when Earth moved in the extreme light area. But the time of this is yet unknown.



Figure 6. The black extinction lines of 65 my ago at Stevns Klint in Demark. Under the line we will see ammonites, above the line almost none. It is an interesting illustration of extinctions, but no test of our hypothesis.

not an important cause of mass-extinctions). The details are a little more complicated because not only the distance towards the Sun may change, but also the tilt of the axis and the speed of Earth (Bertotti, 1990; Roy, 1988).

The distances of the orbit towards the Sun show variation in course of time; it is a picture so to say of the chaotic element, having the form of a logistic function. We could speculate and say extinctions have the form of logistic cycles, which you will see with a growth coefficient of e.g. 3.5. So we may expect various peaks or mass extinctions in succession. This is clearly not caused by a death-star around Earth (Muller, 1990), but by chaotic movements of Earth itself.

So changes in orbit of planet Earth, the celestial factor, will have consequences for the structure of the surface of Earth (because of the influence on lava) but also for all living creatures upon it, in ways the old and even young philosophers would never have dreamt of. Chaos in the solar system has, according to the Academia Arena (2011) publication, an unexpected influence on evolution and extinction, which we can see in the fossil record. We can say now that something must have happened in space.

The orbit of Earth was sometimes wider or narrower. Happily for us the other planets followed in this dance, so preventing collisions. The consequences could be that planet Venus was sometimes very near to the Sun, and Mars very far away from the Sun. If we speculate on these facts we could say that they may have caused total extinction of life, if ever present, on our neighboring planets.

REFERENCES

- Alvarez W, Assaro F (1990). An extraterrestrial Impact, *Sci. Am.*, 263: 78-84.
- Bennett K (2010). The Chaos-theory of Evolution, *New Scientist*, 2782: 28-31.
- Bertotti B, Farinella P (1990). *Physics of the Earth and the Solar System*, Kluwer Academic Publishers, p. 479.
- Coffin MF, Endholm O (1993). Large Igneous Provinces, *Sci. Am.*, 269(4): 26-33.
- Courtillot VE (1990). A Volcanic Eruption?, *Sci. Am.*, 263(4):85-92.
- Darwin C (2009). *Het ontstaan van soorten*, Olympus, p. 544.
- Hall N (1991). *The New Scientist Guide to Chaos*, London, Penguin Books, p. 223.
- Hannam J (2009). *God's Philosophers: How the Medieval World Laid the Foundations of Modern Science*, Icon Books, London, p. 448.
- Hardison OH (1989). *Disappearing through the Skylight: Culture and Technology in the Twentieth Century*, Viking Press, 1989.
- Jacobs G (2002). *The fittest will survive, traveling through Indonesia in the footsteps of Joseph Conrad and Alfred Wallace*, Amsterdam, p. 188.
- Magee B (1974). *Popper*, Utrecht, The Spectrum / Auditorium, p. 533.
- Muller R (1990). *Nemesis, the Death Star - Story of a Scientific Revolution*, Mandarin, p. 208.
- Newell ND (1967). *Revolutions in the History of Life*, In: *Uniformity and Simplicity. Special Paper 89*, by Albritton C. (ed), *Geology Society of America*, pp. 63-91.
- Noort PC (1995a). *Complexity and Survival*, Eburon, Delft, p. 71.
- Noort, PC (1995b). *Evolution, Mass extinctions and the Chaotics of the Solar System*. *Speculations Sci. Technol.*, 17(1995): 85-92.
- Peterson I (1993). *Newton's Clock, Chaos in the Solar System*, W.H. Freeman and Co., p. 317.
- Pleitgen HO, Richter PH (1986). *The Beauty of Fractals; Images of Complex Dynamical Systems*, Springer Verlag, Berlin, p. 199.
- Roy AE (1988). *Orbital Motion*, Taylor & Francis, p. 548.