

*Full Length Research Paper*

# Neural network based CAD model for the design of rectangular patch antennas

Vandana Vikas Thakare<sup>1\*</sup> and Pramod Singhal<sup>2</sup>

<sup>1</sup>Department of Electronics and Instrumentation Engineering, Engineering College, Keetham, Agra, India, 282007.

<sup>2</sup>Department of Electronics Engineering, Madhav Institute of Technology and Science, Gwalior, India.

Accepted 1 September, 2009

**A new method of calculation of patch dimensions of a rectangular microstrip patch antennas using Artificial Neural Network (ANN) has been adopted in this paper. An ANN model has been developed and tested for rectangular patch antenna design. It transforms the data containing the dielectric constant ( $\epsilon_r$ ), thickness of the substrate ( $h$ ), and antenna's dominant-mode resonant frequency ( $f_r$ ) to the patch dimensions that is length ( $l$ ) and width ( $w$ ) of the patch. The results obtained using ANNs are compared with the simulation findings. The simulated values are obtained by designing the microstrip antenna using IE3D electromagnetic simulator. The ANNs results are more in agreement with simulation findings.**

**Key words:** Microstrip antenna, bandwidth, simulation, modelling, neural networks, CAD.

## INTRODUCTION

Microstrip antennas due to their many attractive features have drawn attention of industries for an ultimate solution for wireless antenna. The existing era of wireless communication has led to the design of an efficient, wide band, low cost and small volume antennas which can readily be incorporated into a broad spectrum of systems (Balanis,1997; Pozar,1992; James et al.,1981). This needs very accurate calculation of various design parameters of microstrip patch antennas. Patch dimensions of rectangular microstrip antenna is a vital parameter in deciding the utility of a microstrip antennas. The rectangular microstrip antennas are made up of a rectangular patch with dimensions width ( $W$ ) and length ( $L$ ) over a ground plane with a substrate thickness  $h$  and dielectric constants  $\epsilon_r$ .

In this paper, an attempt has been made to exploit the capability of artificial neural networks to calculate the resonating frequency of rectangular microstrip patch antenna. Neural networks have recently gained attention as a fast and flexible vehicle to EM /Microwave modeling, simulations and optimization. Recently CAD approach based on neural networks has been introduced in the microwave community for modeling of passive and active

microwave component (Zhang and Gupta, 2000; Zaabab et al., 1994; Mishra et al., 2000; Watson et al. 1998) and microwave circuit design. Number of papers (Nurhan et al., 2006; Peik et al., 1998; Devi et al., 2002; Lakshmi et al., 2007; Patnaik et al., 1997; Karaboga et al., 1999) indicates how ANN can be used efficiently to calculate different design parameters of microstrip antennas. In this work, the authors extend the work on the use of the artificial neural network (ANN) technique in place of conventional numerical techniques for the microstrip antenna design.

## DESIGN AND DATA GENERATION

As an example microstrip line feed rectangular patch as shown is designed to resonate at 8 Ghz frequency with dielectric constant ( $\epsilon_r$ )=2, substrate thickness  $h$  =1 mm,  $L$ =12.6mm,  $W$ =15.3mm. The length and the width of the patch are calculated by the given relationships (1), (2), (3) and(4).

$$W = \frac{v_o}{2f_r} \sqrt{\frac{2}{\epsilon_r + 1}}$$

\*Corresponding author. E-mail: [vandanavt\\_19@rediffmail.com](mailto:vandanavt_19@rediffmail.com).

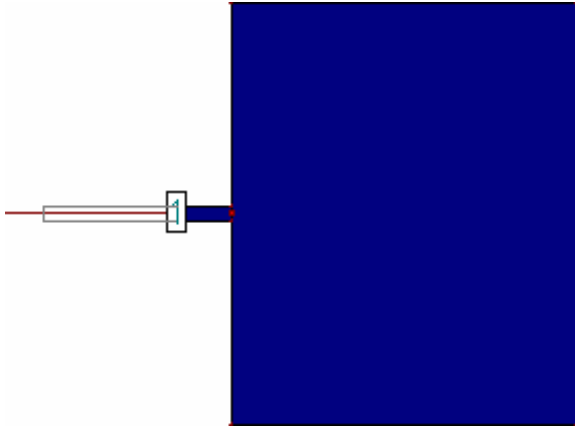

Figure 1. Microstrip line feed microstrip antenna.

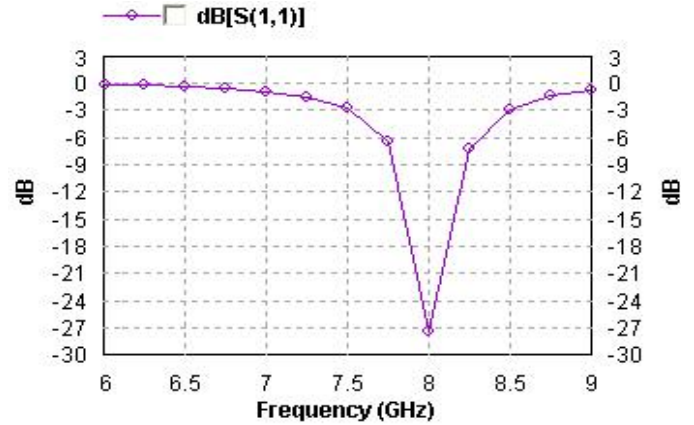

Figure 2. The return loss (S<sub>11</sub>) in dB verses resonating frequency of microstrip antenna.

Where;  $v_o$  is the free space velocity of the light.

$$L = \frac{v_o}{2f_r \sqrt{\epsilon_{reff}}} - 2\Delta L \tag{2}$$

$$\frac{\Delta L}{h} = 0.412 \frac{(\epsilon_{reff} + 0.3) \left( \frac{W}{h} + 0.264 \right)}{(\epsilon_{reff} - 0.258) \left( \frac{W}{h} + 0.8 \right)} \tag{3}$$

Where;  $\Delta L$  is extension in length due to fringing effects and effective dielectric constant is given by;

$$\epsilon_{reff} = \frac{\epsilon_r + 1}{2} + \frac{\epsilon_r - 1}{2} \left[ 1 + 12 \frac{h}{W} \right]^{-1/2} \tag{4}$$

With the calculated values of various design parameters, the patch antenna is designed for 8 GHz resonating frequency. The exact position of feed point can be determined by using IE3D Electromagnetic Simulator. Microstrip antenna with microstrip line feed is shown in Figure 1. The width of the microstrip line was taken as 0.5 mm and the feed length as 2 mm. The patch is energized electromagnetically using 50 ohm microstrip feed line. The geometry is as shown in the Figure 1.

IE3D software from Zeland Corporation has been used to calculate the return loss (S<sub>11</sub>) and hence the cut off frequencies of the antenna. IE3D software have been used to generate data in the form of cutoff frequencies for 1.5\_  $\epsilon_r$  \_ 3.5, 1 mm \_h \_2.5 mm, 11 mm \_ L \_ 13.5 mm and 13 mm \_W \_17 mm. The generated data were then

arranged in six matrices. The four matrices containing the values of  $\epsilon_r$ , h, f1 and f2 are used as the input to the network. The other two matrices containing the corresponding values of L and W are the outputs of the network.

Figure 2 shows the return loss (S<sub>11</sub>) verses frequency curve for the given physical dimension. The length, width, substrate thickness h and dielectric constant ( $\epsilon_r$ ), were varied for the specified range to see the effect on the microstrip antenna bandwidth. It was observed that antenna performance could be controlled by varying these parameters to a large extent.

### APPLYING NEUROCOMPUTING TECHNIQUE

In the present work, we have adopted the same optimization strategy that is used for error back propagation algorithm (Simon, 2000; Mohamad, 1999; Naser-Moghaddasi et al., 2007) .Out of the 245 data generated, 230 were used for training and the rest were used for testing of the trained neural network. The optimized values of different parameters, which are obtained by trial and error for the training of the network, are: 1) the number of input nodes = 4; 2) the number of neurons in the hidden layer = 40; 3) the number of output node = 2; 4) the learning rate parameter = 0:002; 5) and the learning rate adaptation = 1:5; three layer network as shown in Figure 3 is proposed that is input layer, hidden layer and output layer.

The various inputs to the network are dielectric constant ( $\epsilon_r$ ), substrate thickness h and the cut off frequencies f1 and f2 and corresponding outputs are length L and width W of the patch . The training time is 45 s and training performs in 1500 epochs. The network architecture preferred in the research work is feed forward back propagation network. The back propagation algorithm is used to train the ANN which learns using gradient decent method. During the training process, the

**Table 1.** Comparison of results of IE3D and ANN for the calculation of patch dimensions.

$\epsilon_r$	h mm	f1 GHz	f2 GHz	W (IE3D) mm	W (ANN) mm	L (IE3D) mm	L (ANN) mm
2	1	7.92	8.244	15.3	15.23	12.6	12.34
2.2	1.4	7.32	7.69	15.6	15.42	12.8	12.42
2.5	1.7	6.69	7.06	15.9	16	13.1	12.96
2.7	1.9	6.37	6.77	13.9	14.1	13.3	13.36
2.9	1	6.40	6.57	13.7	13.75	13.5	13.44
2.6	1.8	7.03	7.47	13.2	12.99	12.2	12.36
3	1.2	6.60	6.92	14.4	14.35	12.4	12.53
2.4	1.7	6.70	7.09	15.4	15.60	13.4	13.21
2.1	1.5	8.64	9.02	13	13.1	11	11.4
2.8	1.6	6.28	6.7	15.2	15.13	13.2	13.10
2.9	1.7	6.08	6.45	15.4	15.50	13.4	13.21
2	1.8	7.11	7.47	15.8	15.78	13.8	13.56
2.8	1.8	6.81	7.21	14.8	14.77	12	12.03
2.9	1.7	6.66	7.05	14.6	14.75	12.2	12.14
2.6	1.7	7.28	7.72	13	12.89	11.8	11.72

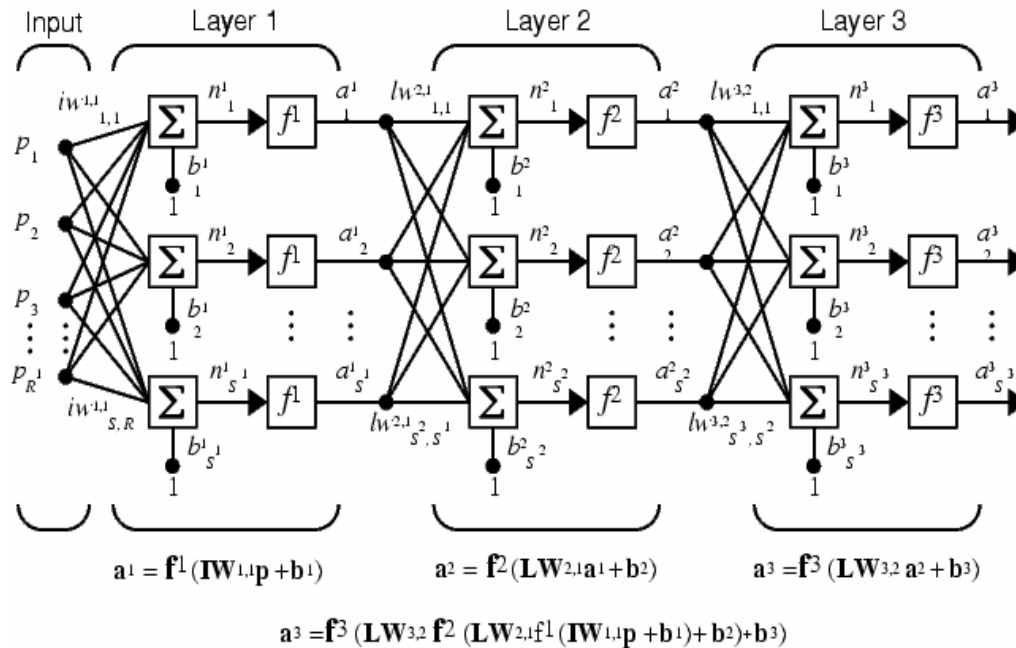
**Figure 3.** Three layer feed forward artificial neural network.

the neural network automatically adjusts its weights and threshold values such that the error between predicted and sampled outputs is minimized. The adjustments are computed by the back propagation algorithm. The training algorithm used is trainlm. The error goal is .001 and learning rate is 0.1. The other network parameters used were noise factor of 0.004 and momentum factor of 0.075. The transfer function preferred is tansig and purelin in the architecture. The feed forward back propagation

network architecture is simulating the antenna design with high efficiency and accuracy.

## RESULTS

A rectangular microstrip patch antenna has been considered. The simulated data of the antenna has been taken from the IE3D Electromagnetic Simulator. Table 1

respectively depicts the comparison of results among ANNs and simulated values. Network testing was performed for those 15 input combinations which are not included in the set of training data and found satisfactory as depicted in the Table 1.

## Conclusions

A neural network-based CAD model is developed for the design of a rectangular patch antenna, which is robust both from the angle of time of computation and accuracy. A distinct advantage of neuro computing is that, after proper training, a neural network completely bypasses the repeated use of complex iterative processes for new cases presented to it. The single network structure can predict the results for patch dimensions provided that the values of  $\epsilon_r$ ,  $f_1$ ,  $f_2$  and  $h$  are in the domain of training values.

## REFERENCES

- Balanis CA (1997). Antenna Theory, John Wiley & Sons, Inc..
- Devi S, Panda DC, Pattnaik SS, (2002). , A novel method of using artificial neural networks to calculate input impedance of circular microstrip antenna. Antennas Propagation Soc. Int. Sym., 3: 462 – 465.
- James JR , Hall PS, Wood C (1981), Microstrip antenna theory and design Stevenage UK: Peter peregrines (IEEE).
- Karaboga D, Guney K, Sagiroglu S, Erler M, (1999), Neural computation of resonant frequency of electrically thin and thick rectangular microstrip antennas. Microw. Antennas Propagation, IEEE Proc., 146: 155 – 159.
- Lakshmi NJ, Sri Rama Krishna K , Pratap Reddy L. (2007). Design of Microstrip Antennas Using Artificial Neural Networks. Proc. International Conference on Computational Intelligence and Multimedia Applications. pp. 332 – 334
- Mishra RK , Pattnaik A (2000). ANN Techniques in microwave engineering, IEEE Microw. Mag., 1: 55-60.
- Mohamad H. Hassoun (1999). Fundamentals of Artificial Neural Networks, New Delhi, Prentice Hall of India, , Chap. 8.
- Naser-Moghaddasi M , Pouya DB, Alireza N (2007). Heuristic Artificial Neural network for Analysing and synthesizing Rectangular Microstrip Antenna” IJCSNS International. J. Comp. Sci. Network Security. 7 (12).
- Nurhan T, Filiz G, T˘ulay Y (2006). Artificial Neural Design of Microstrip Antennas ,Turk. J. Elec. Engine.,14 (3).
- Pattnaik A , Mishra RK, Patra GK, Dash SK (1997). An artificial neural network model for effective dielectric constant of microstrip line, IEEE Trans. Antennas Propagation. 45: 1697.
- Peik F, Coutts G, Mansour RR (1998). Application of neural networks in microwave circuit modelling, Electrical and computer Engineering, IEEE Canadian Conf. 2: 928-931.
- Pozar D. M.(1992)., Microstrip Antenna , Proc. IEEE, 80: 79-81.
- Simon H (2000). Neural Networks, second edition pHL.
- Watson PM, Gupta KC, Mahajan RL (1998). Development of knowledge based artificial neural network models for microwave components, IEEE Intl. Microwave W p. Digest, pp. 9-12, Baltimore MD
- Zaabab AH, Zhang QJ, Nakhla M (1994). Analysis and Optimization of Microwave Circuits & Devices Using Neural Network Models, IEEE, MTT-S Digest, pp 393- 396
- Zhang Q.J, Gupta KC, (2000.). Neural Networks for RF and Microwave Design, Artech House Publishers,