

Full Length Research Paper

Simplification of Jaw crusher for Artisanal Aggregates Miners

Emrod Elisante

Department of Chemical and Process Engineering, University of Dar es Salaam.P. O. Box 35131 Dar es Salaam, Tanzania. E-mail: elisante@udsm.ac.tz. Tel.: +255-754-865695.

Accepted 30 June, 2009

A small-scale mobile jaw-crusher unit with a throughput of 1-1.5 tons of aggregates per hour has been designed, manufactured and tested at the Department of Chemical and Processing Engineering, University of Dar es Salaam. The equipment is aimed at reducing the drudgery and hardships faced by artisanal miners, mostly women, who spend long hours in quarrying sites excavating and crushing aggregates using manual tools. The aim was to design a low-cost unit powered by bicycle pedals however this objective was defeated by economic constraints like labor cost and product price, as well as, technical limitation of the human physique and stamina to sustain pedaling of heavy inertial flywheels required to overcome the actual load and intermittent shock-loads. Instead a simple air-cooled engine 2.94 kW was used causing a 25% increase in investment cost but had 6 fold improvement in productivity over bicycle power and 30 fold boost over manual tools like sledge hammer, pickaxe and crowbars previously used by miners. The crusher was successfully field tested for 3 months by Umoja ni Nguvu women group at Kunduchi Mtongani quarry site to crush 6-8" limestone rocks to aggregates of various sizes 1/2", 3/4" and 1" required for road and building construction of roads on the outskirts of Dar es Salaam city. Based on the field data and an investment cost of Tshs 3.5 million, a financial profitability analysis indicated that the crusher project has a daily net-inflow of Tshs 259 thousand and a pay-back period of two months. Since the unit requires low level of technical skills and is not capital intensive it is recommended for micro- and medium scale aggregates miners and can be deployed in peri-urban quarries or remote villages without electricity grid.

Key words: Jaw-crusher, size reduction, power requirement, small-scale mining.

INTRODUCTION

The technology and equipment for size reduction such as jaw-crushers, gyratory crushers, hammer mills, and ball mills have been in application for the past 70 years (Coulson and Richardson, 1999). Some are automated and operated by open- or closed-circuit grinding mode which includes conveyer belts, bucket elevators and screening and classification equipment. Due to its capital intensiveness, the application of size reduction technology in Sub-Saharan Countries has been limited to few players mainly international foreign companies which construct roads, build houses, or operate large-scale mining. In the middle of 1990s Tanzania witnessed a huge upswing of building construction activities which created a demand for aggregates beyond that could be supplied by existing large-scale quarries. This prompted a new vocation of aggregate miners, mostly women, who use manual tools like pickaxe, crow-bars and sledge hammers to mine and process limestone or granite rocks

to feed the booming construction industry.

Although miners earn their livelihoods (Jambiya et al., 1997) through sale of aggregates, the occupation is undertaken under adverse conditions and characterized by:

1. Low productivity as it takes a man 3 weeks and a woman 4 weeks to produce a 7 ton lorry of limestone aggregates worth US\$ 80 less production costs.
2. Health risks and safety hazards that cause bodily injury of fingers by sledge hammers, eye injury from flying stone chips, and respiratory ailments due to dust inhalation (Elisante, 2003).
3. Drudgery and hardship involving over 10 hours per day of toiling on hot sunshine.

The tools and techniques employed by artisanal miners are outlined in Table 1, Figures 1 and 2 show women

Table 1. Tools and Techniques Used by Artisanal Aggregate Miners in Tanzania.

Step	Process	Tool	Purpose	Party
1	Demarcation	Pickaxe and spade	Marking the area to be excavated	Mostly men
2	Excavation	Pickaxe and crowbar	Excavate large rock boulders up to 1 m in diameter	Men
3	Pre-crushing	10 kg sledge hammer	Reduces large boulders to ¼-½ meter diameter stones, which can be carried by carts or buckets	Both
4	Transportation	Buckets and trolleys	Carrying stones to crushing or selling point	Women
5	Crushing	2-5 kg sledge hammers	Crushing stones to final sizes- ½", ¾" or 1" diameter	Women
6	Sieving	Metal screen, fork, and shovel	Removing fines from product	Women



Figure 1. Crushing Rocks from 6 to ½ - 1 Inch Size.



Figure 2. Screening and grading the product.

crushing and grading limestone aggregate products.

In Tanzania artisanal aggregate quarrying activities can be seen almost everywhere in small towns and big cities like Dar es Salaam, Mwanza and Arusha where men, women and children work round the clock in quarry sites. In Dar es Salaam they scavenge limestone rocks left behind by large-scale miners in open-pit mines located in Kunduchi Mtongani, Boko and Salasala areas. In Arusha they crush granite stones in semi-commercial quarries in Sombetini and Sakina areas located a few metres off the Arusha-Nairobi highway. It is estimated that more than 15,000 people countrywide earn their livelihood through artisanal quarrying activities (Elisante, 2003).

In developed countries the construction of roads and houses is undertaken by large-scale contractors, who procure bulk aggregates from commercial quarries. A typical jaw-crusher grinding 3-20 tons per hour costs US\$ 20-50,000 for equipment (MachineRoll, 2008); plus US\$ 20,000 for working shade, concrete foundation and purchase of 25-50 Hp prime movers. Due to high capital cost the technology it is not very affordable in developing countries like Tanzania. As a result, there have been attempts to de-scale jaw-crushers and other size reduction equipment to match budgets of small-scale miners or road contractors using labor based technologies. The New Dawn Engineering of South Africa developed a manually operated portable jaw-crusher (Crispin, 1997); which costs about US\$ 3,000. However the crusher has a low throughput producing about one ton per day and is physically tasking requiring two people to operate comfortably. In this work a simple jaw-crusher is proposed and developed for small-scale aggregate miners, the aim is to simplify complex and massive large-scale equipment to obtain a technology that can be manufactured using technical skills and engineering resources (Peters et al., 2005) available in developing countries.

For the sake of brevity, detailed engineering issues pertaining to design and manufacture of components and sub-systems are not included here, only major issues like choice of technology and estimation of power requirements are reported, other pertinent information is outlined in Itika and Elisante (2004).

Estimation of power requirements

The major challenge faced in developing the crusher was to choose the appropriate power source and thus size of equipment. Too high power input from electric motors or diesel engines may give equipment with high throughputs but too expensive to be affordable by the target group. On the other hand, low power input from humans or animals may result into a cheaper crusher but with low productivity comparable to manual tools (Elisante and Itika, 2004). In general size reduction equipment are highly energy intensive whereby it is estimate that only 0.1-2% of energy is utilized effectively (Coulson and Richardson, 1999), the rest is lost as sound, heat and

friction. Efficiency depends on the magnitude and manner of energy application, that is, compressive, impact, shear or attrition. The energy requirement of size reduction equipment can be estimated as:

$$\frac{dE}{dL} = -CL^p \quad (1)$$

Where; C is a proportionality constant and L is particle length. For fine particles (100-2000 (m) the value of $p = -2$ and integration leads to Rittinger's Law (Perry, 1985). For coarse particles 1 mm and above $p = -1$ which leads to Kick's Law and for intermediate particles $p = -1.5$ leading to Bond's Law. Figure 3 shows specific power requirements versus particle size as estimated by Bond, Rittinger, and Kick's Laws. The aggregate required by building and road construction range from 0.25 to 1 inch, which can be considered as intermediate particle hence the energy required can be estimated using Bond's Law:

$$E = E_i \left(\sqrt{\frac{100}{L_2} \left[1 - \frac{1}{q^2} \right]} \right) \quad (2)$$

Where $q = L_1/L_2$ in which L_1 and L_2 are initial and final size respectively. E_i is Bond's *work index*, which is the amount of energy required to reduce unit mass of material from infinite particle size to a size of 100 μm . Apart from mode of energy application, the physical properties of materials to be ground such as: moisture content, structure, friability, density, hardness, crushing strength, as shown in Table 2 are important design criteria as they affect both the life of liners and power requirement.

METHODOLOGY

Choice of technology

The basic data and information gathered from Kunduchi Mtongani quarry site such as type of tools and techniques used by artisanal miners (Table 1) formed the basis for design of the jaw-crusher. However the choice of technology was also influenced by a matrix of other socio-economic and technical factors like:

1. Gender non-displacement due to introduction of new technology.
2. Feed size of 3-6 inches consistent with existing techniques and tools used by miners as shown in Table 1.
3. Product size range of 1/2-1 inch consumed by the local construction industry.
4. A throughput that is economical in terms of time and investment.
5. Wide applicability to crush different rocks from softer materials like gypsum and dolomite to hard and abrasive like quartz, limestone and granite.

Design and development

The salient features of the crusher are as shown in Figure 4. Mech-

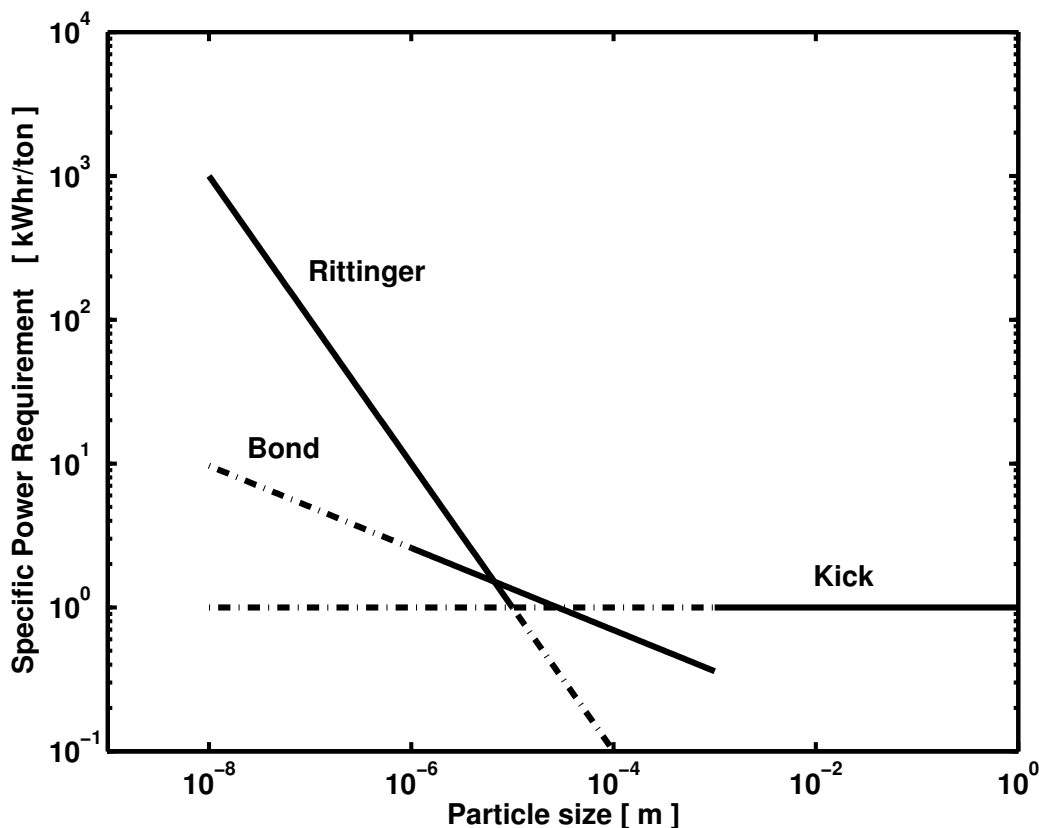

Figure 3. Power Requirement versus Particle size for Bond, Rittinger, and Kick's Laws (Source: Coulson and Richardson, 1999).

Table 2. Physical properties of rocks processed by Artisanal Miners in Tanzania (Source: Perry, 1985).

Rock type	Density [g/cm ³]	Abrasion index [-]	Work index [kWhr/ton]
Limestone	2.69	0.0256	11.61
Granite	2.68	0.3937	14.39
Quartz	2.64	0.1831	12.77
Gold ore	2.86	0.2000	14.83

anical engineering design sketches and component drawings were done using the AutoCAD software and simulation and analysis of power requirement was done by user written MATLAB program codes. Fabrication of welded sub-assemblies and machining of parts like pulleys, shafts, was undertaken at the College of Engineering and Technology (CoET) workshops but castings were sub-contracted to a local foundry- Kinota Engineering of Dar es Salaam. Particle sieving was done using Rotap sieve shaker model Karl Kolb, D-6012 with 9 sieves, shaking time of 20 min and rotary speed of 6 rpm. The particle size distribution was then analyzed using the micro-soft excel software.

RESULT AND DISCUSSIONS

Since power of rotating equipment is related to torque T and rotational speed n as $P = 2\pi nT$, the increase in rota-

tional speed results in high power consumption and high through-put as shown in Figures 5 and 6, which are plotted for a gap size of 15 mm. The relation between power and throughput can be obtained by combining Figures 5 and 6 to obtain Figure 7 which also shows power predicted using Bond's Law. The theoretical values of power are computed using Bond's law for limestone that has a working index of 11.4 kWhr/ton hence it is expected that if the crusher will be used for hard granite rocks which have a working index of 14.15 kWhr/ton the power requirement shall increase by 20% giving a maximum power of 2.7 kW at 300 rpm, which is still below the engine nominal power of 2.94 kW.

The power requirement computed using Bond's Law seems higher than those measured experimentally as

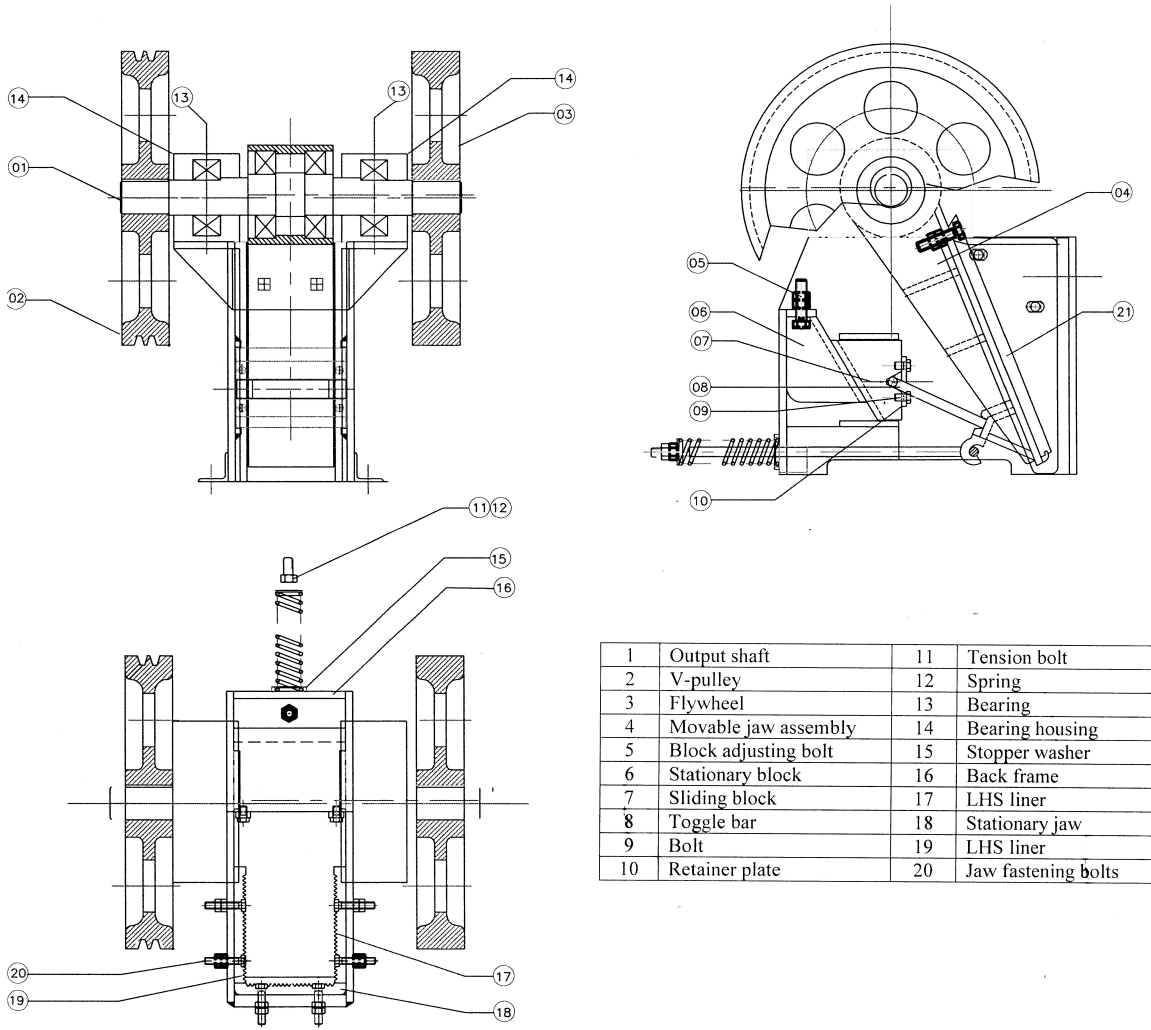

Figure 4. Assembly drawing of the Jaw-crusher unit.

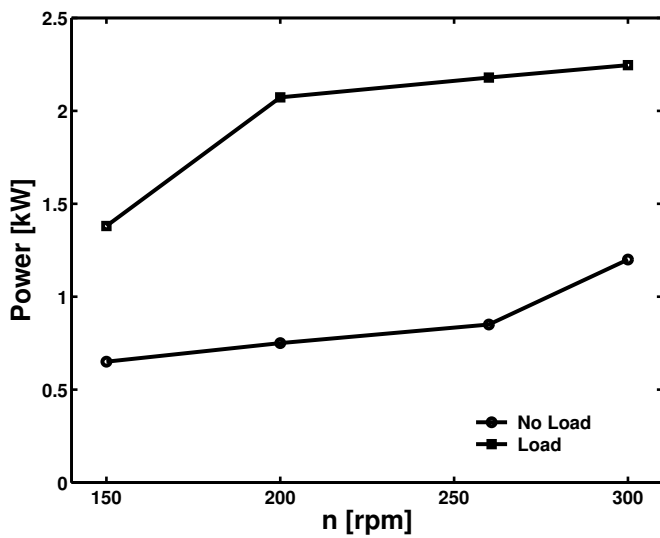

Figure 5. Power versus output shaft rotational speed.

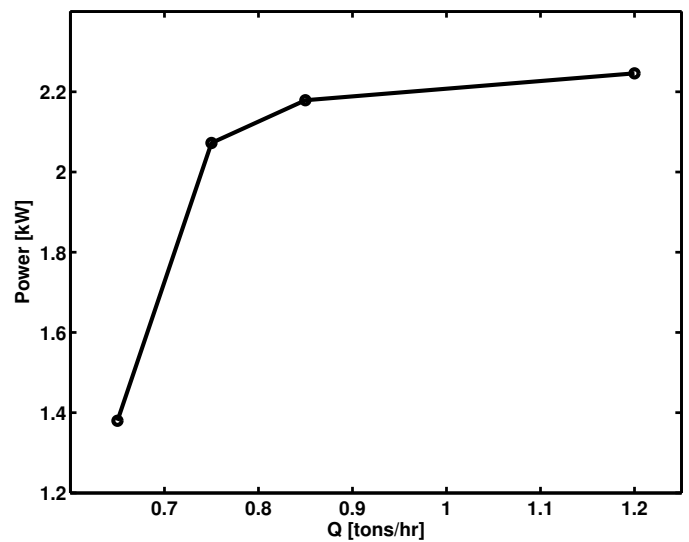

Figure 6. Power versus through-put for a 15 mm gap.

Table 3. Summary of profit-and-loss account of crusher as projected in 2009.

Description	Amount per day [Tshs]	Per Month (25 days) [Tshs]
Sales revenue (Aggregates 130,000/= per 7 tons)	259,000	6,475,000
Variable Costs (Stones, diesel, lubricants, maintenance, operator wages, plus 5% overheads)	125,980	3,022,250
Fixed Costs (License, salaries, security)	6,500	195,000
Total Operating costs	132,480	3,217,250
Gross profit	126,520	3,257,750
Depreciation (12% p.a. on equipment)	1,151	28,767
Income tax (25% of gross-profit)	31,342	807,246
Net profit	94,027	2,421,737

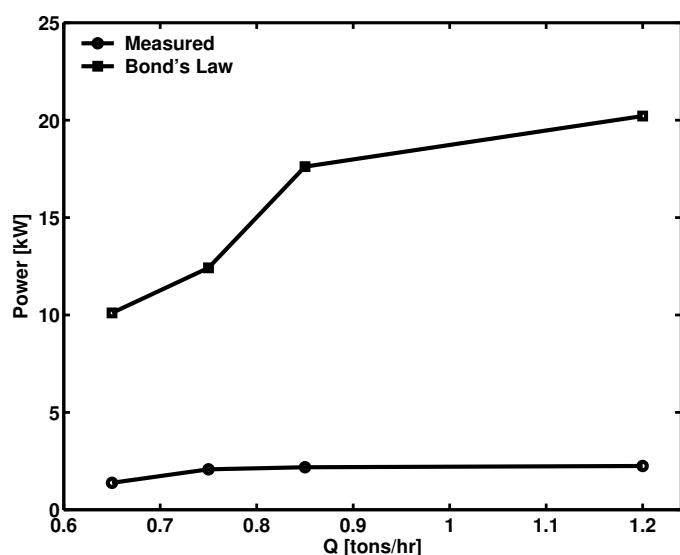

Figure 7. Power versus throughput for theoretical and actual case.

shown in Figure 7. This could be attributed by the fact that the working indices obtained from literature are applicable to limestone products different from those obtained from Kunduchi Mtongani. The power requirement was thus determined from the maximum load. The engine power rating was set at 25% more than the power demand imposed in order to prevent overloading by inadvertent entry of harder materials or choke feeding. The electrical power measured at maximum load is 2 kW hence the engine power was computed as follows:

Out requirement; 2 kW
 Assumed efficiency; 70%
 Actual engine power; $2/0.7=2.86$ kW

Based on these requirements, an air cooled diesel engine model Z170F made in China by Yuyao Power Machinery Works was chosen. The horizontal single-cylinder four-stroke, engine has a rated speed of 2600 rpm giving a nominal power of 2.94 kW and a maximum power of 3.23



Figure 8. Field tests in collaboration with Umoja ni Nguvu women group.

kW. With a net weight of 40 kg, the engine satisfies versatility requirement as the whole crusher unit weighs roughly 150 kg hence it was possible to mount it on a mobile unit that can be towed by two people within the quarry perimeter as shown in Figure 8.

In order to evaluate the technical performance and cost-effectiveness, the crusher was installed and tested in collaboration with Umoja ni Nguvu women group at the Kunduchi Mtongani quarry site for a period of three months July to September 2006. About 100 tons or 15 seven-ton lorries of aggregates were crushed. One lorry takes 5-6h, which is faster compared to 3-4 weeks required to get the same quantity for manual crushing! Table 3 gives projected 2009 profit-and-loss account summary using actual 2006 field data. Based on an investment of Tshs 3.5 million, mainly as cost of the crusher, and a ten-hour working day, a monthly net profit of Tshs 2.4 million is obtained. This means that if there is no major breakdown and market conditions are favorable, the project has a pay-back-period of two months only!

During the course of crusher tests, several improvements were effected on the crusher sub-systems such as:

- i) Adaptation of feed hopper.
- ii) Incorporation of sieving mechanism.
- iii) Installation of additional safety guards.
- iv) Installation of a clutch to decouple the crusher from engine motion when jams occur.

Conclusion and Recommendations

A mobile jaw-crusher unit has been developed for artisanal aggregates mining. The unit is suitable for application in labor-based road construction projects, low-cost housing sector and in small-scale mining such as:

- i) Crushing gold ore prior to panning.
- ii) Crushing limestone or dolomite before burning in kilns.
- iii) Crushing coal lumps for briquette making.

The crusher has been field tested for crushing limestone rocks and was found to be technical viable and economically feasible with a pay-back period of two months. The engine seemed to perform well based on field observation like sound during heavy loads and absence of over-heating even for non-stop crushing of 3-4 h. However more tests are needed to validate the engine using different raw-material like gold ore, gypsum or granite which has a higher working index and abrasion index compared to limestone as shown in Table 2.

REFERENCES

- Coulson JM, Richardson JF (1999). *Chemical Engineering*, 4th Edition, Butterworth-Heinemann Publishers, Oxford 2: 56.
- Crispin P (1997). ILO-ASSIST Bulletin No. 6 of September.
- Elisante E (2003). Technology Development to Improve Productivity of Women Miners/Processors of Limestone Aggregate in Dar es Salaam City, Concept note submitted to Research for Poverty Alleviation (REPOA) Organization, Tanzania pp. 1-2.
- Elisante E, Itika AJ, Wakati R (2005). Development and Field-Testing of a Small-scale Stone Crusher, Field test report No. CPE-JC-01-2005 Department of Chemical and Process Engineering, University of Dar es Salaam, Tanzania.
- Itika AJ, Elisante E (2004). Development of a Low-Cost Jaw Crusher Unit, Research Report No. CPE-JC-02-2004, Department of Chemical and Process Engineering University of Dar es Salaam, Tanzania p. 5.
- Jambiya GK, Kulindwa K, Sosovele H (1997). Poverty and the Environment: The Case of Informal Sand-mining, Quarrying and Lime-making Activities in Dar es Salaam, Tanzania, Research on Poverty Alleviation (REPOA), Research Report No. 97.1, p. 17.
- MachineRoll (2008). <http://www.machineroll.com/products.html>
- Perry RH (1985). *Perry's Chemical Engineers' Handbook*, 6th Edition, Mc Graw-Hill Company, New York p. 812.
- Peters JE, Elisante E, Romijn HA (2005). Commercialization of a Small-scale Stone Crusher Technology in Tanzania, MSc Dissertation, Industrial Engineering and Management Department, Eindhoven University of Technology, The Netherlands p. 34.