

*Review*

# Evaluation of hydrojacking and hydrofracturing behavior in Aghajari formation (Gotvand dam site foundation), Iran

Ajalloeian R.<sup>1</sup>, Fatehi L.<sup>2\*</sup> and Ganjalipour K.<sup>3</sup>

<sup>1</sup>Science Faculty, Isfahan University, Isfahan, Iran.

<sup>2</sup>Geology Department, Vazvan Pyamenoor University, Tehran, Iran.

<sup>3</sup>Mahab Ghods Engineering Co., Saderat Iran, Nahid Branch, Tehran, Iran.

Accepted 5 January, 2011

Regarding the construction of large dams, definition of hydraulically and hydro mechanical conditions of rock mass is necessary. This paper summarizes the results and evaluation of hydraulic jacking and hydraulic fracturing tests conducted in Aghajari formation in different depths. Lugeon testing was carried out in selected boreholes in order to study the groundwater characteristics of the Aghajari formation. The results of sealing grouting and consolidation test grouting have been assessed. Hydro jacking phenomenon has the best performance among the phenomena of Aghajari formation during grouting. In addition, the hydrofracturing pressure especially in first stages has been evaluated. On the basis of these behaviors and their interpretations, appreciable changes have been observed in grouting pressures and designed mixes. However, the changes were considered for optimizing the grouting pressure and water tightness design, as well as the economics.

**Key word:** Hydraulic fractures, SPI, P-Q diagrams, Gotvand Dam, Aghajari formation.

## INTRODUCTION

Gotvand dam site is situated at 30 km north-west of Shushtar city and 12 Km away from Gotvand city in Khuzestan province, south of Iran. It is the last series of dam project on the Karun River. This project, which is one of the biggest dam and power plant projects in Iran, has 180 m height rock fill dam with concrete core, a 760 m long crest and about 27 million m<sup>3</sup> volume of dams' body. The volume of the reservoir is about 4.5 billion m<sup>3</sup>, while the capacity of the power plant is about 1000 MW and can be extendable up to 2000 MW. The other purposes of the dam are agricultural and recreational uses.

Gotvand dam site foundation includes Aghajari formation. A petrographic view of this formation is a bedding of siltstone and mudstone with interbedding of thick sandstone. In addition, gypsum veins are present in primary and secondary states, so that the primary gypsum

veins which are parallel to bedding and secondary gypsum veins are joint fillers. Thicknesses of the gypsum veins are often in millimeter and, in some cases, reach few centimeters. Interfacing terms of lithology and interfingers which are automatically abundant in this area are observed. However, formation age is essentially done in the Mio- Pliocene period (Figure 1).

## STRUCTURAL GEOLOGY

The area is designed with marginal folded Zagros and with an instantaneous Dezful plate (Berbrian, 1995). In fact, the site and surrounding area are part of the Zagros (folded Zagros). The most important trust of the area is Pyrahmad trust with 60 Km length that has developed to the right side of the dam. Trust branches in the Gotvand dam site are branches that carried an anticline in the edge (Mahab Qods, 2004).

Base on the Jamison division (Jamison, 1990), the type of fault related fold is diagnosed by fault propagation fold. Therefore, the fault surface is developed and observed in

\*Corresponding author. E-mail: [danesh.sci@gmail.com](mailto:danesh.sci@gmail.com), [danesh\\_sci@yahoo.com](mailto:danesh_sci@yahoo.com). Tel: +982282472828, +98912694018.

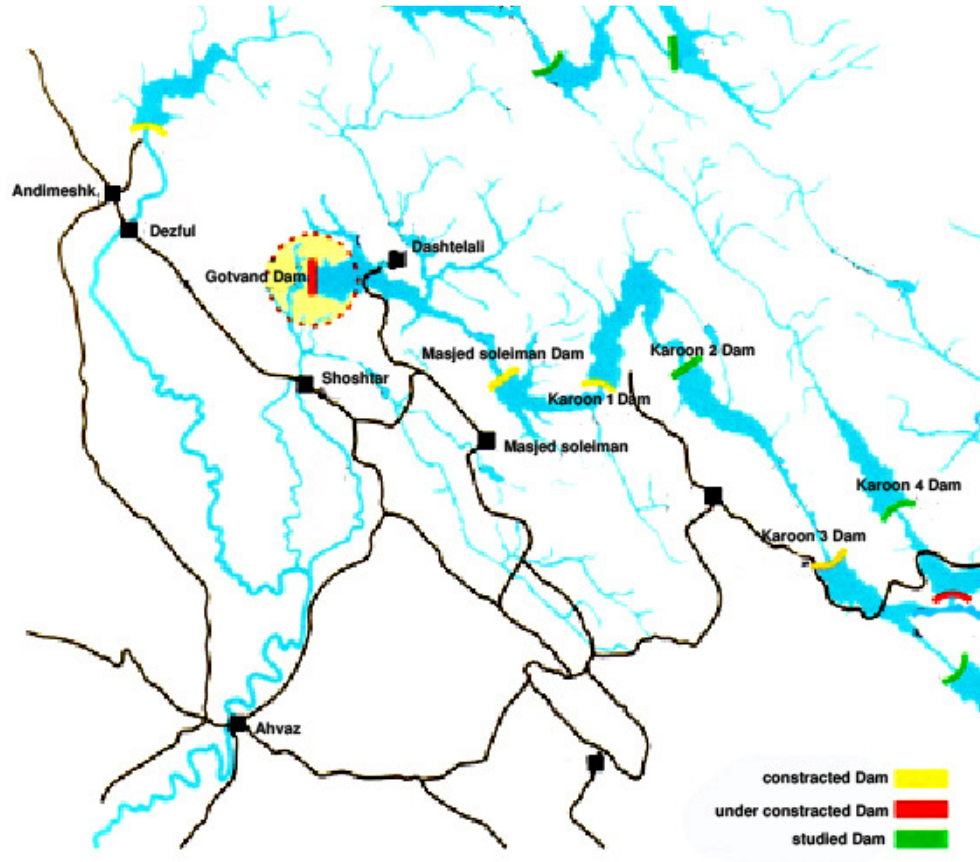

Figure 1. Geographical map.

the dam site foundation, and its processes are investigated. In geology, the profile location and its anticline is well observed. The anticline south slope (for deep limb), found in the edge of the anticline that suffered severe movement close to fracturing, is vertical, while the northern edge slope is about 40 degrees to the north with less fracturing.

The folding mechanism with competent sandstone layers and incompetent siltstone and mudstone layers is a flexural-slip type, which leads to fracturing and reverse faulting in the anticline edge. In excavations and cutting foundation (Figure 4), several compressed and fractured zones are observed.

The conditions are a characteristic of a flexural-slip type of folding mechanism (Twiss and Moor, 1992), in which the described conditions have direct effect on the interpretation of Lugeon test and grouting results.

## RESEARCH THEORY

### Water pressure test (WPT)

The result of this test, aided with a diagram, introduced 5

behaviors: linear, tabulated, joint filling, joint wash and distention.

Kutzner (1996) found 5 behaviors (Figure 4), based on P-Q diagram (Figure 2), but it was different from the viewpoint of Housby. However, Ewert did a geology interpretation on Lugeon test, using P-Q diagrams. In addition to the 5 behaviors, he interpreted the WPT results, so that, saturation and tight rock mass, for the first time, is used to analyze hydraulic fractures. For the first time, Lugeon described water pressure test (Nonviler, 1996), and then other researchers did many interpretations on these tests. However, Housby (1990) interpreted this and the hydro-jacking phenomenon.

Hydrofracturing has become a standard method for determining the *in-situ* state of stress in rock masses used in engineering design, and is one of the few methods available for testing the deep boreholes (Haimson, 1993). The method consists of sealing off a short segment (typically 0.6 m) of a borehole at a desired depth (using inflatable packers), injecting fluid (usually water) into the isolated zone at a sufficient rate to raise the hydraulic pressure rapidly and bring about hydraulic fracturing of the borehole wall. This fracturing occurred due to Lugeon test pressure, natural fracture and

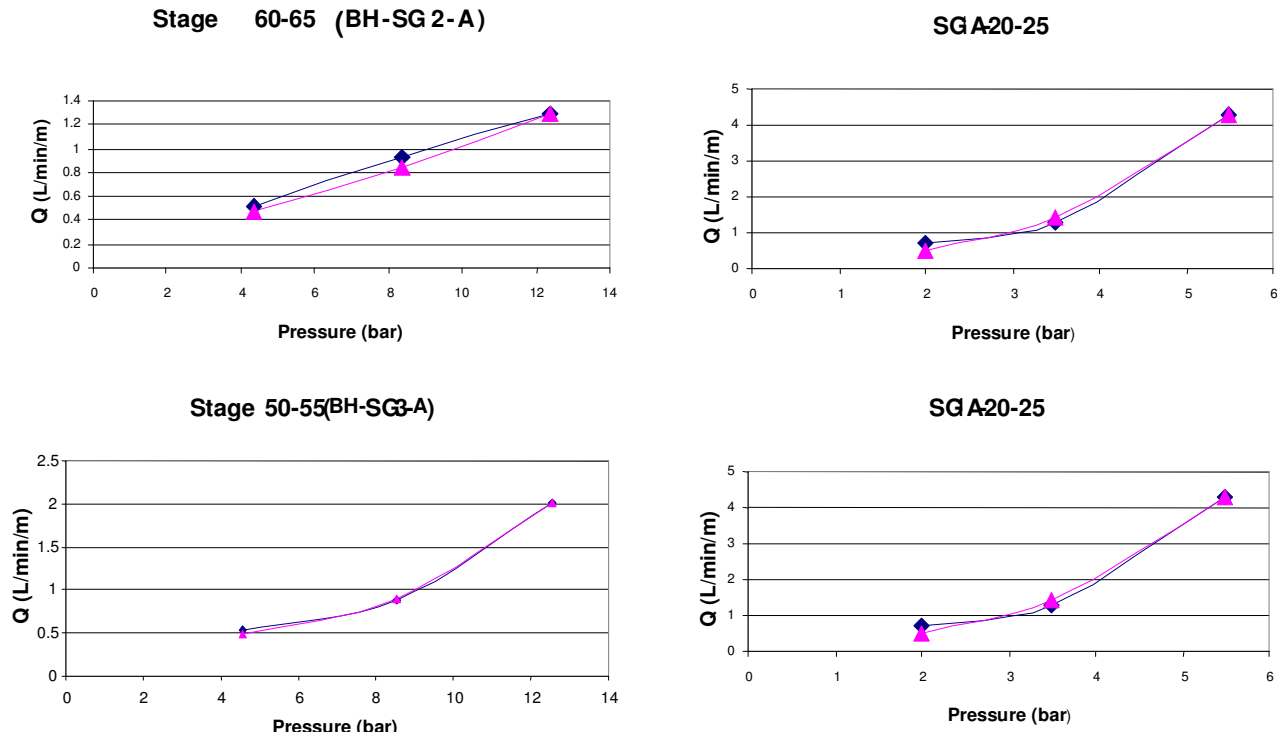

Figure 2. P-Q typical diagrams.

lithology type known as rock mass permeability or secondary permeability.

In this regard, another formula is presented by Foyo scientists in determining the secondary permeability, including the secondary permeability index (SPI) that is determined as follows:

$$SPI = C \left( \ln \left( \frac{(2le/r) + 1}{2(3.14 le)} \right) \right) (Q/H t)$$

C= constant coefficient [related to viscosity of fluid in the rock mass ( $10^{-4}$  c)]; Q= rate of absorbed water by rock joints (liter); Le= length of grouting piece (meter); r= radius of borehole (meter); T= time applying pressure (s); H= total pressure (water column).

The proposed index has the following features:

1. The index (SPI) is based on classical parameters such as water pressure and water absorption. Also, the index does not require converting to Lugeon (convert to Kf).
2. The index unit is ( $l/s.m^2$ ); however, it is related to the rock mass that was used to introduce a rock mass classification.

### Rock mass classification based on SPI

This index has the following two aspects:

1. A source for rock mass classification.

2. Expresses the permeability.

Based on SPI, rock is classified into four groups (Figure 3). The provided classification does not prove the strength and geomechanic characteristic of a rock, but only classified it based on permeability.

#### Class A

If rock permeability (based on SPI) is  $2.16 \times 10^{-14}$   $l/s.m^2$  or less, it is placed in class A, which then makes the rock to become impermeable and the best class of rock, and so, it does not need improvement. The rock permeability in this class is equivalent to less than one lugeon.

#### Class B

If the permeability is in the following ranges,  $2.16 \times 10^{-14} \leq SPI \leq 1.72 \times 10^{-13}$   $l/s.m^2$ .

The rock permeability in this class is equivalent to the 1 to 8 lugeon, while the permeability is relatively low or appropriate and so, need to be improved locally.

#### Class C

If the permeability is in the following ranges,  $1.72 \times 10^{-13} \leq SPI \leq 1.72 \times 10^{-12}$   $l/s.m^2$ .

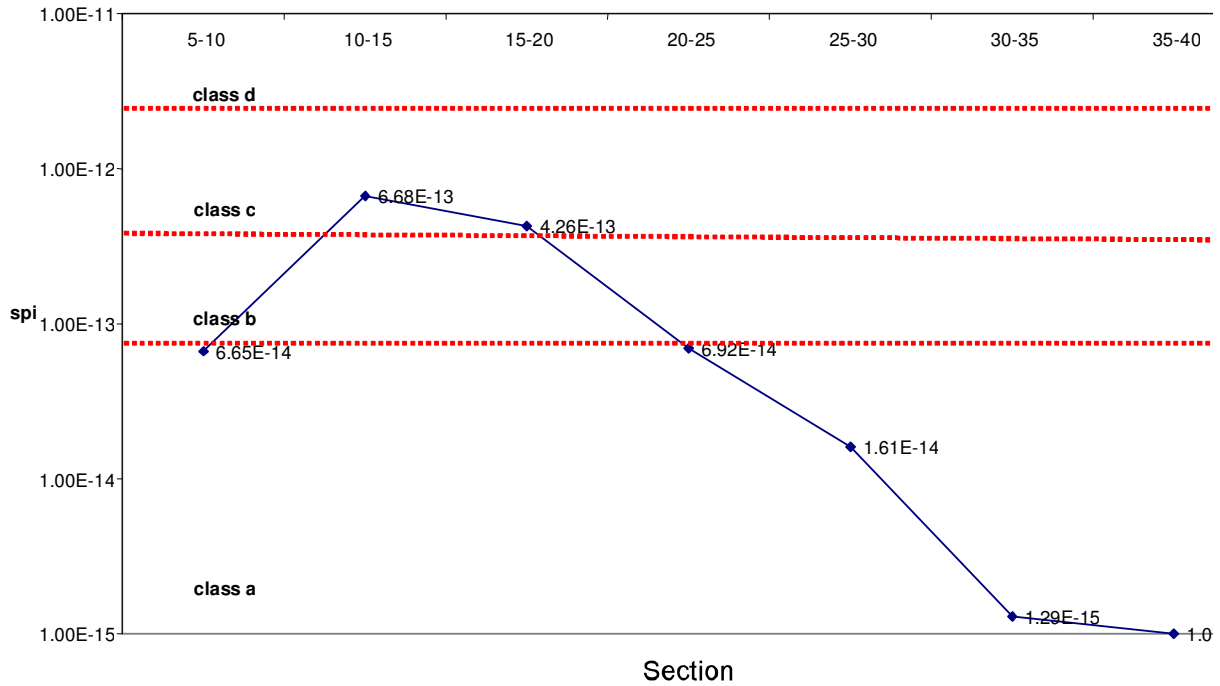

Figure 3. The rock mass classification based on SPI.

The rock permeability in this class is equivalent to over 8 lugeon, while the permeability is high and so, need to be improved.

**Class D**

If the permeability is in the following ranges,  $1.72 \times 10^{-12} \text{ l/s.m}^2 \leq \text{SPI}$ . The rock permeability in this class is equivalent to over 80 lugeon. For this status, the rock needs to be widely improved.

During water pressure test, it is recognized that characteristics of fractures and hydraulic routes are affected. These changes influence permeability of rock and rock classification, respectively. Therefore to present a suitable classification of rock mass and also its permeability, there is need to identify the changes that will happen during the test PT-SPI diagrams which describe these changes, appropriately.

The identified PT-SPI is categorized in four types as follow:

**Type A:** In this type of diagram, a fixed amount of SPI is used to calculate the different pressures of SPI, which means that the result of SPI for the increasing and decreasing pressure steps are similar together. Thus, SPI in relation to the maximum pressure is used to classify the rock mass.

**Type B:** Type B indicates the wash behavior of fractures.

This process starts from the beginning of the test. The resulted index of the decreasing pressure is higher than the increasing pressure, while the higher SPI amount is applied to categorize the rock.

**Type C:** It indicates the fracture behavior or hydraulic jack during the test. In this diagram, due to opening a current crack, a break exists. Before this break happens, the pressure is chosen as PC or a critical pressure, in which type A is placed in the increasing point of the diagram. It shows that because of the happened fracture, SPI indices relating to the decreasing pressure are more than the increasing pressure, and the index related to the critical pressure will be applied for rock mass classification. Also, SPI after the critical pressure indicates a throbbing rock mass classification because of hydraulic fracture.

**Type D:** This type shows the caulk of the existed fractures by means of the fillers in each section. The filled cracks which cause the decrease of SPI along advanced pressure are developed, and sometimes, the drop in the decreasing pressure disappears (turbulent current) and the least SPI is used in the rock mass classification.

**Assessment of the damaged piece in effect of the hydraulic fracture phenomenon**

Hydrofracturing occurs when the fluid pressure in the

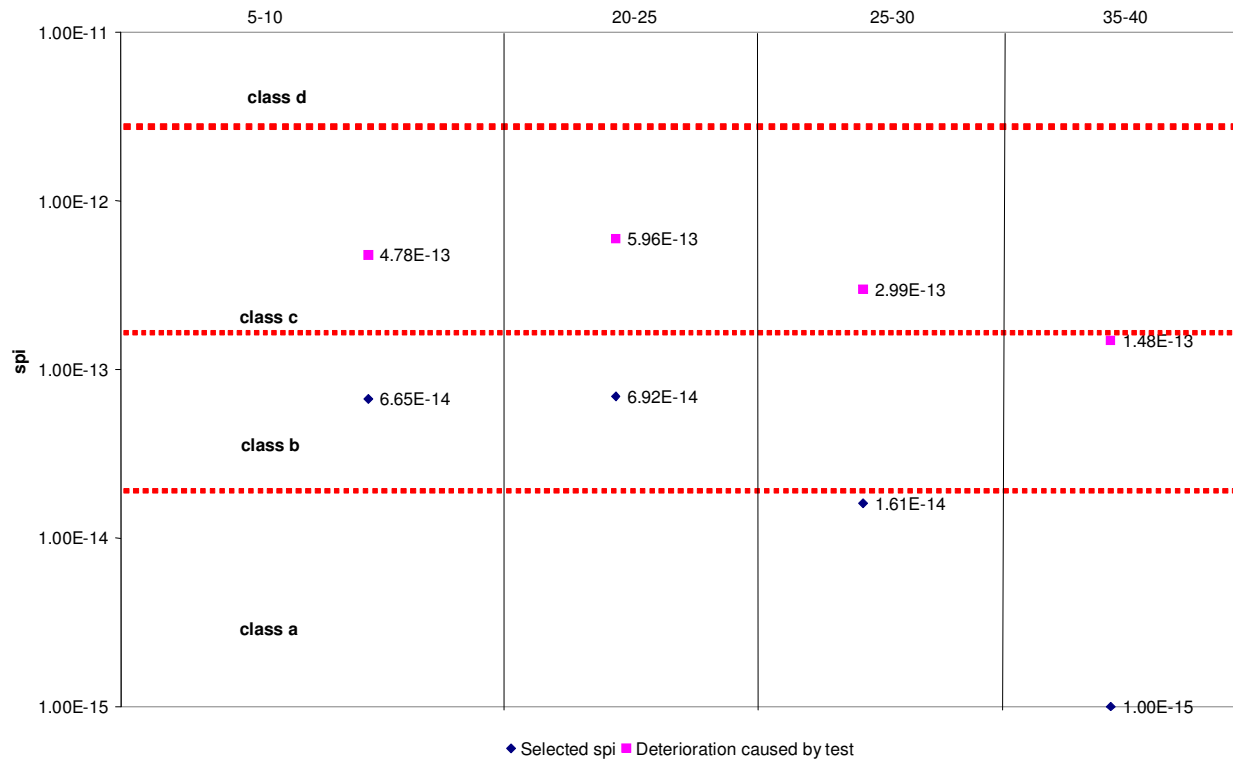

Figure 4. Hydraulics route.

isolated portion of the borehole reaches a critical level, called “breakdown”. At breakdown, the rock fractures in tension cause the borehole fluid loss and a drop in pressure. When pumping is stopped, the hydraulic line feeding the test interval is held shut. The pressure value that is realized when the injection ceases and when the test zone is “shut in” is called the shut-in pressure. In any case, the shut in pressure reflects a balance between the internal pressure in the fracture and the *in-situ* stress acting on the fracture face.

The hydraulic jacking or fracturing which causes a major change in rock mass classification is based on SPI, and this phenomenon is easily identifiable by PT-SPI usage. This phenomenon is similar to the type A diagram that is before the critical pressure of the curve. On arrival of the critical pressure PC, the intimidated pressure appears in SPI, due to the fact that the SPI which is related to the critical pressure is introduced as rock mass classification. Consequently, the rock mass damage is explained by the highest amount of SPI.

By application of the suggested factor of SPI, it is possible to grade the amount of changes in rocks due to the hydraulic fracture which is based on the case study introduced in 3 groups:

1. Less vulnerability in effect of hydraulic fracture.
2. Average vulnerability in effect of hydraulic fracture.
3. High vulnerability in effect of hydraulic fracture.

Low vulnerability and quality drop in the hydraulic fracture's effect are not that much when compared to that of the rock which is graded on its own. In middle vulnerability, quality drop is enough to transfer the rock quality to the down level, in that this phenomenon just happens when opening cracks, whereas in high vulnerability, quality drop is enough to transfer the rock quality to two different down levels, in that this phenomenon just happens when a new crack appearance exists.

### Lugeon test in Aghajari formation

The review and interpretation of the said test has been done based on the valuable borehole of CH7-13 test grout in Aghajari formation (with a triangle shape and distance of 2 m from each other) and also on compacted grouts in this unit. Moreover, the study found SPI searches that were done only in the borehole of CH7-13. Generally, more than 50% of the results of permeability show permeability >1 Lu and the maximum result of permeability in the first borehole was about 30 Lu. As a result, the continuous grout made by the first borehole to reach the control borehole has caused the noticeable drop of other boreholes.

In Figure 5, the RQD results, the digit of Lugeon and the slush grout of the test grouting boreholes depth are

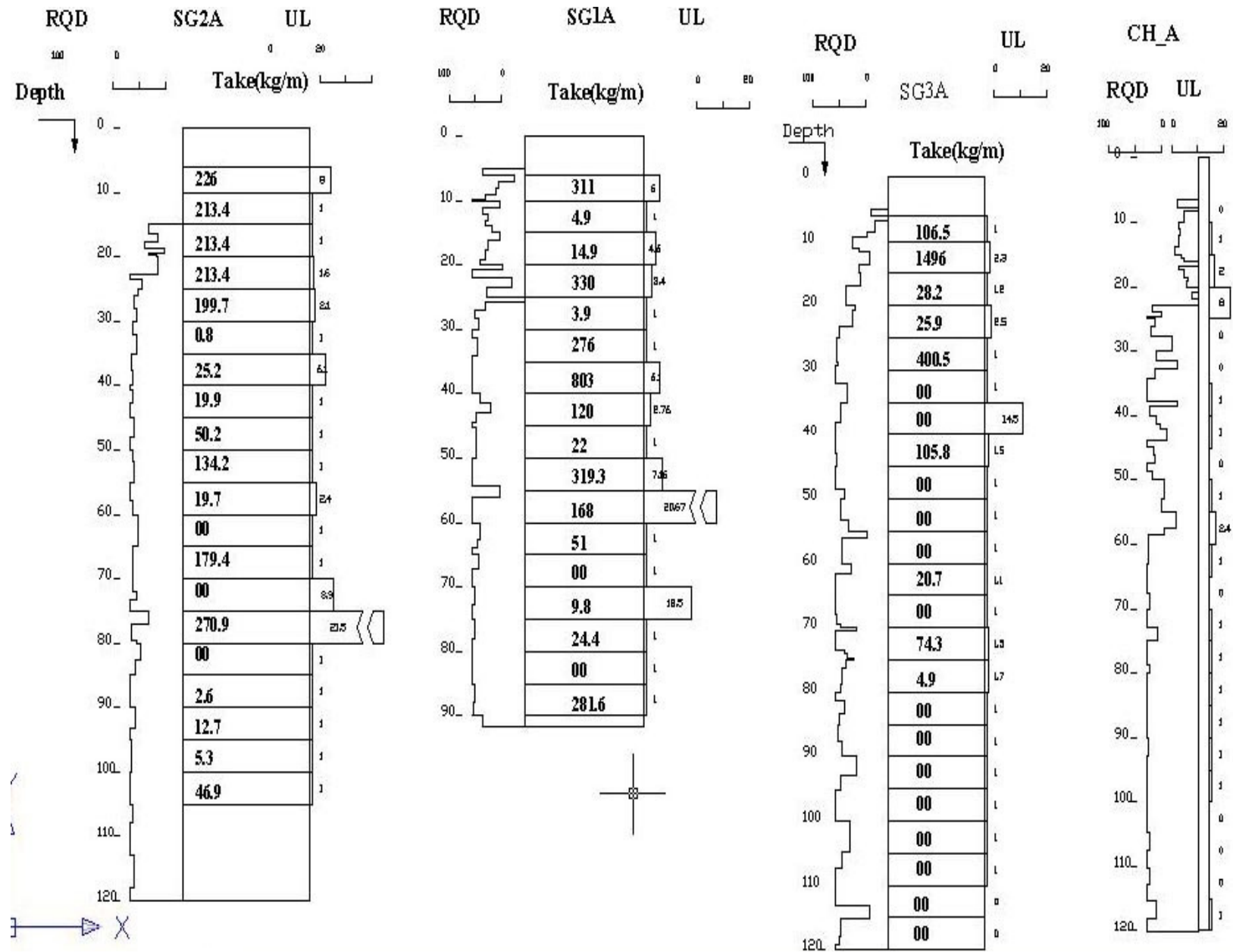

Figure 5. Permeability and grouting results and rock mass quality in test grouting boreholes.

**Table 1.** Depth and pressure in Lugeon tests.

	30-25	25-20; 20-15	15-10	10-4	Depth
	2-4-6-4-2	5/1-3-4-3-5/1	1-2-3-2-1	5/0-1-2-1-5/0	Pressure step (bar)
5/2-5-7-5-5/2					
	55 to the end	50-45	45-40	40-35	Depth
	4-8-12-8-4	5/3-7-10-7-5/3	5/3-7-9-7-5/3	3-6-8-6-3	Pressure step (bar)

**Table 2.** Hydrojacking and fracture.

Depth	Critical pressure	Hydraulic behavior
5-10	3.15	Hydro jacking
10-15		Erosion
15-20		Back curve
20-25	5.15	Hydro jacking
25-30		Hydro jacking
30-35	11.14	Saturation
35-40		Hydro fracture

shown. These tests have been done in the cracked unit of Aghajari formation which has the steep of the right angle.

### Pressure steps and interpretation of the rock mass behavior during passing fluids

In the various depths, different pressure steps have been used. In Table 1, it could be seen that after 55 meters depth, back and forth steps were used alike. Although the applied pressure in the borehole CH7-13 is highly accomplished carefully, the resulted behaviors of P-Q diagrams describe the linear behavior to expand the rock mass against water stream. In similar interpreted cases, the turbulent behavior was influenced. In Ewert's classification (Evert, 1992, 1997a), the linear and turbulent behaviors are both equal, and they have an expression of the permeable behavior that will be accepted when introduced. In Figure 4, same P-Q as samples is shown, while permeability is dependent on the pressure taken from the P-Q diagrams. According to hydraulic behavior, the permeability was mainly in type C, whereas according to classification, based on SPI, depth 20 to the end of borehole CH7-13 was placed in class A, while the first 20 meters are in B and/or C. According to the permeability diagram, the hydraulic route of the fracture sections and the hydraulic jack are realized from each other separately and these results are shown in Table 2. However, diagrams of rock mass classification and permeability of hydraulic routes would be subsequently shown as the study proceeds.

### Hydraulic fracture

To express the rock mass behavior during fluids movement, it is important to approach the hydraulic fracture of pressure in order to get the critical pressure ( $P_{crit}$ ). In most of the rock masses, there are latent fractures that, usually, are completely closed and as such, a static tension will be applied on them. During the hydraulic fracture process, the seepage of under-pressure water causes a domination of the static tension and thus opens the discontinuity. In addition to the geomechanic view, the said section during the test, from the point of view of permeability, reach the condition of total loss as well. This fracture could happen via water or liquid cement. Hydraulic fracture process completely depends on the earth structure and conditions and material of rocks. Also, the pressure needed for it to break is different in every depth.

In the place of Gotvand dam construction, grouting pressure reached the fracture level in some sections.

Furthermore, the fracture happened meaningfully in none of the lugeon tests. As such, the study of P-Q and SPI diagrams explains it very clearly. In Figure 4, same examples of these behaviors are shown. Depending on the conditions and target of grouting of every hydraulic fracture, the construction dam could be useful or injurious. However, the hydraulic fracture during consolidation grouting in place of the Gotvand dam during test grouting would be determined. During these grouting in Zone 3, the study observed that the slope of layers is obtuse (right angle), while the pressure of fracture changed between 6 and 7 times in the first 10 m. During fracture, the race of discontinuity and grout leakage in depth of 60 m of the cavern is sometimes visible, and this mainly happened in sedimentation and, in some cases, in other discontinuities (Graph 2). In zones which have layers less than 40 degree angle, the layers slope is lower, and in the first 10 m, even when pressure was applied 12 times, the fracture did not appear.

Concerning the aim of fixation and grouting which is to protect the safety of rock and fortify it, the designed pressure for doing this work is determined under the aforementioned criteria.

According to the same material of the earth, earth construction has affected the threshold pressure of fracture noticeably.

In other words, fracture is done easily under less pressure in layers that had right angle or so in Aghajari formation. Nonetheless, hydro fracture assess in depth, has to be done with high attention.

### Hydro jacking

The evidence about test grouting in Aghajari clearly states that the hydro jacking process occurred in primary levels. The first borehole's attraction of the test grouting triangle (90 m length) was totally about 16210 kg cement and 282 kg bentonit, while the second borehole (120 m) totally attracted 8955 kg cement and 168 kg bentonit and the last one which has been grouted by super lubricant, attracted totally, 11126.69 kg cement and 176 kg bentonit.

By grouting the first borehole and, usually, lubricating the second and third borehole in triangles, the grout dropped. According to lugeon tests, which are based on expansion and linear behavior from the one hand, and harsh fracture of Aghajari formation, fracture expansion and breaks with little space on the other hand, the use of fracture grouting which has the most opening will be grouted. The applied pressure at the moment brings about the closing of fractures which have the least opening and finally, by deleting the pressure, they will have the slightest cement attraction.

In the test, grouting was accomplished for a real calculation. This behavior was also seen in the middle lugeon results after excavation and grouting of the first two boreholes, while in the third borehole (SG3A), a lubricant was used.

This change in the composition of grout caused the lubrication of the third borehole cement in relation to the second one, and also in the first 45 m of the third borehole in relation to the first one (SG1A), the change increased (from 9000 to 13332 kg), while in these conditions in relation to the last applied pressure, the existing discontinuity systems grouted simultaneously. As such, these conditions indicate the presence of hydro jacking during grouting. In hydro jacking, there is a high strain in the elastic level of the rock mass. While performing pressure grouting, the edge of discontinuity completely opens and the grout is transferred to distant places. On the cavern of grouting in Aghajari formation,

during lugeon testing and grouting, after opening the packer, grout or water came out from the head of the borehole compactly, and this was due to the field investigation of hydro jacking. However, the use of the lubricant to smoothen the slurry rub in all fractures of borehole plays a very important role.

### Conclusion

1. The geological structure in the critical pressure of grouting has a direct role.
2. The hydraulic fracture found in the component of the vertical stratigraphy occurred more easily and with less pressure.
3. The hydro jacking process occurred in the applied pressure of the experiment's grout in Aghajari formation, so that the packer after an hour of grouting brings out water from the borehole.
4. In creating hydraulic jack process, strains and jointed litology have an important effect.
5. Using lubricant so that grouting can have a greater uniformity with every discontinuity.
6. The fracture pressure level, on vertical layers, in the first section of Aghajari formation in compacted grouting (using vertical borehole) is 5 to 7.

### REFERENCES

- Berbrian M (1995). Master blind thrust hidden under Zagros folds. *Tectonophysics*, p. 241.
- Ewert FK (1997). Grouting examples and ground water flow in rock - Part 1. *Dam Eng.*, 8(1): 141-146.
- Ewert FK (1997). Permeability testing by means of water pressure tests - Part 2. *Dam Eng.*, 8(2): 343-352.
- Ewert FK (1998). Grout ability and grouting of rocks - Part 4. *Dam Eng.*, 8(4): 271-325.
- Ewert FK (1998). Hydro geological regime around dams and reservoirs - Part 3. *Dam Eng.*, 8(3): 274-286.
- Haimson BC (1993). *The Hydraulic Fracturing Method of Stress Measurements: Theory and Practice*. Fundamental Rock Eng., Fairhurst, C. ed., pp. 396-412.
- Houlsby AC (1990). *Construction and design of Cement grouting*. p. 442.
- Kutzner CH (1996). *Grouting of rock and soil*. p. 271.
- Twiss M (1992). *Structural geology*, p. 402.