

*Full Length Research Paper*

# Mathematical modeling, simulation and analysis of rice grain movement for design and fabrication of low-cost winnowing machine

Krishna Prasad Shrestha\*, Pradeep Parajuli, Bivek Baral and Bim Prasad Shrestha

Department of Mechanical Engineering, Kathmandu University, Dhulikhel, Kavre, Nepal.

Received 14 August, 2016; Accepted 9 November, 2016

Winnowing called “*Dhan Battaune*” in Nepali is the process of separation of unwanted matters from paddy after threshing. In the conventional method; it requires at least four person to produce strong wind by bamboo basket (“*Nanglo*” in Nepali) to blow away straw, leaves of grasses and other unwanted matters; process starting with one of them pouring the sun dried grains from certain height. To perform MATLAB simulation for designing the screening chamber, a sample of 20 rice grains out of half kilogram was selected to measure its length, width and thickness. To locate the flow pattern, grains of highest weight 0.0324 mg and mean weight 0.0228 mg were considered and simulation was performed in MATLAB with drag coefficient 0.4 which indicated screening chamber as 0.4 m × 0.4 m. The rice-husk movement was also observed in ANSYS CFX which validate the result obtained from MATLAB as the recommended screening chamber design clearly separate them owing to their weight differences. Series of modification were done for better performance of the machine. This resulted in a final product having 0.16 m × 0.10 m grain outlet and 0.20 m × 0.20 m husk outlet in which 19 kg of rice grain were tested in average separation time of 70.8 s for five trails. The overall productivity of the machine was calculated to be 966.10 kg/h which is a promising result for the power consumption of 3.10 units per hour.

**Key words:** Cascade, drag force, grain regulator, iterative model, screening chamber, trajectory of rice grain.

## INTRODUCTION

Rice production is a three step process –pre-harvesting, harvesting and post harvesting –carried out by male and female labor (Mejia, 2003). Winnowing process is the part of post harvesting process, generally performed by females. It is dejection to say that Nepal, being an agrarian country, eyes on foreign countries for

agricultural technology and advances. The sophisticated machineries imported from abroad are designed for the systems with low capital cost and high labor cost though the scenario is reverse in context of Nepal; labor is cheap and capital is expensive. This entuses the farmers to adopt inappropriate technologies that results

\*Corresponding author. E-mail: [kp@ku.edu.np](mailto:kp@ku.edu.np).

in not only higher percentage of agricultural failure but also larger gaps in income distribution (Manandhar et al., 2009). As a result, appropriate technologies targeting the poor and marginal farmers (about 70%) need to be implemented promptly to witness any elevation in its productivity. Manpower scarcity is being one of the burning problems in agrarian arena as a vast number of young people are migrating to Malaysia and Gulf countries seeking the job placement and leaving the agricultural burden to old and female labors. Demands of mechanization is increased to reduce the operational time so that the saved periods can be utilized in income generating activities, child health care, education and recreation (Manandhar et al., 2009). It not only reduces the human drudgery and farm work load but also assists in resulting high crop yields with cropping intensity.

As winnowing is a post harvesting process, the harvested rice grains are dried in the sun usually for 4 to 5 days before storing it in traditional source called “*Bhakar*”. Winnowing process is well known as “*Dhan Battaune*” in Nepali language. It is an iterative process, required time and again to separate grains from unwanted matters like weed, straws, empty grains, sand, dust particles etc. to give cleaner outcome (Accetta et al., 2013). It is commonly carried out by women in mid hilly areas of Nepal like *Panauti*, *Nala*, *Panchkhal*, *Shankhu*, *Banepa* etc. while by men in Terai region. It demands huge human effort as at least four people are required. The traditional methods demand long hours of arduous task resulting in fatigue and loss of concentration. Often, natural wind velocity may be unfavorable for the winnowing task to be performed thereby increasing operating time and difficulties (Muhammad et al., 2013). During this period, most of the women schedule their winnowing process in the morning or evening. After completion, one could see blister or swollen portion in their hands which is due to very hard labor to move “*Nanglo*” –a bamboo basket that produces air force to drive away unwanted materials–to and fro. They are on need of winnowing machine that can perform the task more conveniently at an affordable cost. Proposed winnowing machine can be developed from local materials and technologies and only requires 2 people and the operation can be performed with much less effort. This product is beneficent mostly to the farmer who has low income and may be also to any marketing company which sells agro-based machineries or any organization that want to help farmer community having low income generation and person who want to lessen the female labor involved in winnowing process in return to spend much time in his/her child care. Plate 1 shows the rice winnowing performed by an old woman of Bhaktapur community (Aurora, 2012).

This study is primarily focused to design, fabricate and test a winnowing machine in order to substitute manual winnowing process with mechanized system.

Among several constraints, accessibility of parts and



**Plate 1** Nepali woman adopting winnowing process by natural air velocity (Aurora, 2012).

cost were focused as major criteria while constructing the prototype (Jang et al., 2014). Advanced computational analysis through MATLAB observation and ANSYS simulation were performed for designing this agricultural machinery. In addition, testing of the machine with different test samples to evaluate its productivity and design modification to take in variety of paddy/cereals was done. The outcome of this study would contribute in reducing women participation for winnowing process and hence use the spare time for other socio- economic activities. This product, once commercialized, will spin off small industries which will create job opportunities at local level.

## MATERIALS AND METHODS

### Sampling

The sampling is the most vital part of the project and is done under the theme of research, to design and fabricate the winnowing machine in order to isolate rice grain from the husk. To design the machine, firstly projectile of the rice grain has to be known. Half kilogram grain was taken and 20 grains were separated

**Table 1.** Length, width, thickness and weight of grains.

S/N	Length (mm)	Width (mm)	Thickness (mm)	Weight (mg)
1	7.19	3.80	2.14	0.0142
2	8.17	3.60	2.26	0.0324
3	7.52	3.80	2.36	0.0221
4	7.20	3.50	2.08	0.0250
5	7.30	3.49	2.18	0.0271
6	7.12	3.60	2.26	0.0225
7	7.55	3.79	2.23	0.0122
8	7.24	3.71	2.21	0.0305
9	6.65	3.33	2.10	0.0228
10	7.57	3.58	2.10	0.0264
11	6.95	3.49	2.20	0.0324
12	7.33	3.53	2.26	0.0230
13	7.76	3.29	2.36	0.0324
14	7.10	3.57	1.76	0.0235
15	7.01	3.46	1.94	0.0321
16	7.38	3.42	2.32	0.0323
17	6.41	3.45	2.44	0.0324
18	6.78	3.41	2.09	0.0275
19	6.63	3.42	2.04	0.0227
20	7.19	3.28	1.41	0.0274

**Table 2.** Projectile motion of the grains varying air velocity.

S/N	Velocity of air (m/s)	Y distance (m)	X distance (m)
1	3 (blue)	0.75	1.96
2	4 (green)	0.75	1.57
3	5 (red)	0.75	1.18

from them. The length, width thickness and weight were measured and tabulated in Table 1. In the table, the grain having 0.0324 mg (highest weight) and 0.0228 mg (mean weight) were chosen for the test of the projectile motion in different velocity field condition.

#### **MATLAB simulation for grain movement inside screening chamber**

Firstly, MATLAB simulation was conducted without considering the masses of grain and drag force (Table 2).

Lesser the mass compared to size, greater will be the drag force experienced by rice grains during the projectile motion (Figure 1). Thus, re-simulation is carried out considering the drag force (Kelvin et al., 2004; Bassett et al., 2005; Peirson, 2007; Tovar, 2009). Taking constant drag force, the maximum distance travelled along x-axis was found to be 0.72 m for 0.0228 mg (mean weight) and 0.48 m for 0.0324 mg (highest weight) rice grain. Both these simulations were carried out with coefficient of drag 0.4. MATLAB simulations were performed in following initial conditions.

Condition 1:

Mass of grain = 0.0324 mg

Velocity field = 8 m/s along horizontal direction Velocity along Y direction = -g\*t  
Coefficient of drag = 0.4

Condition 2:

Mass of grain = 0.0228 mg  
Velocity field = 8 m/s along horizontal direction Velocity along Y direction = -g\*t  
Coefficient of drag = 0.4

The graph obtained from the constant drag force simulation for rice grain trajectory is shown Figure 2.

On the basis of this simulation, length and height of screening chamber was selected 0.4 m x 0.4 m. During this simulation, following assumptions were taken into consideration in accordance to Tomomi and Nauruse (2008):

1. Air is incompressible.
2. The density of rice grain is much larger as compared to that of air.
3. The rice grain is considered to be ellipsoidal shape with uniform diameter and density.
4. The collision between rice grains is negligible.
5. The rice grain volume fraction is very low.

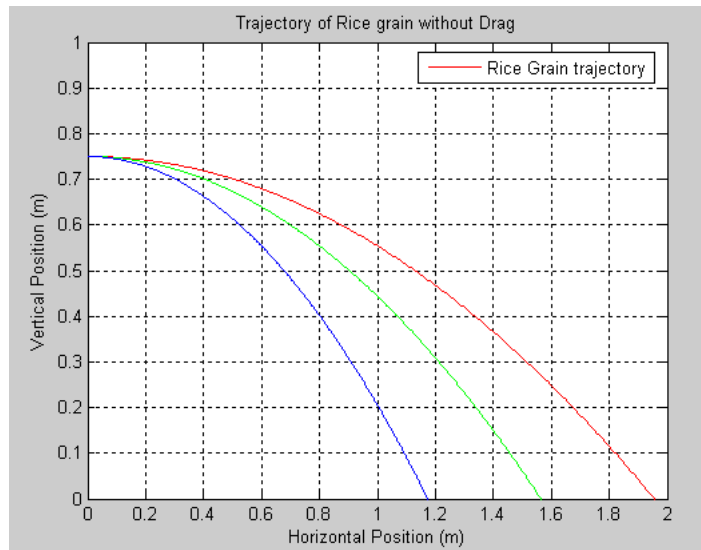

Figure 1. Trajectory of rice grain without drag.

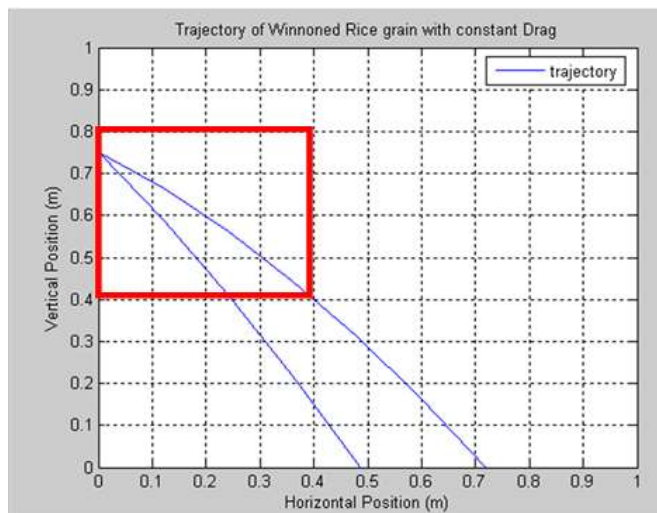

Figure 2. Trajectory of rice grain with constant drag.

Table 3. Dimension of screening chamber.

Length	0.4 m
Width	0.2 m
Height	0.4 m

**Determination of dimensions of screening chamber**

Tomomi and Nauruse (2008) reported that for the test box ratio of width: Length = 1, the freely falling bodies produce much vortex (Uchiyama et. al., 2008). So, to neglect the vortex effect, width: length ratio was chosen as 0.5. The dimensions of length and

height were obtained from MATLAB simulation. The final dimension of the screening chamber was found in Table 3.

**ANSYS simulation**

ANSYS simulation process includes three steps: Pre-processing-specify boundary conditions; solver, define convergence criteria and post processing, analyze results.

**Design of domain and meshing**

A screening chamber model along with fan housing, hopper, grain and husk outlet was created in Solid Works and then imported in ANSYS CFX. The domain was discretized to generate smaller units

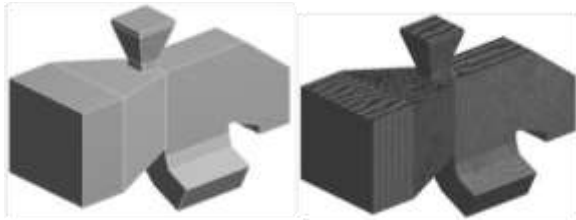

Figure 3. Design of model and showing meshing in it.

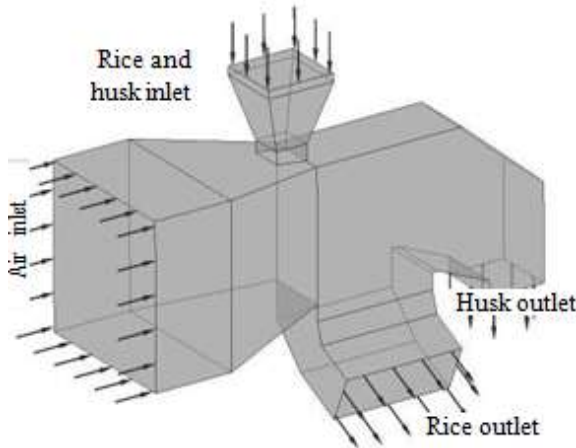

Figure 4. Boundary condition for simulation.

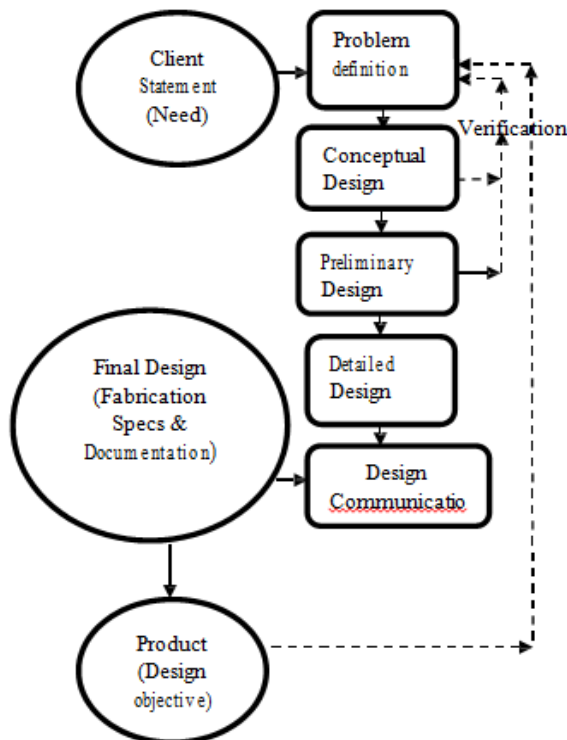

Figure 5. Adopted prescriptive, five stage iterative model of the design process (Dieter et. al., 2000).

by hex dominant meshing with free face mesh type set to “All Quadrilaterals” to produce uniform meshing (Figure 3).

**Boundary condition and convergence criteria**

Two inlet and two outlet boundary conditions were provided. First inlet was specified with air bulk mass flow rate of 0.28 kg/s and fluid values of air = 1, rice = 0 and husk = 0 were given. Similarly, bulk mass flow rate of 0.268 kg/s was provided along with fluid values -air = 0, rice = 18/28, husk = 10/28. The two outlets - rice and husk outlet were given static pressure of 1 atm. The maximum iteration was set to 300 with RMS residual type and residual target as 1.E-4 (Figure 4).

**Design process**

This iterative model of design process is followed among different linear and sequential models (Figure 5). Feedback mechanism is the major reason behind this as better results can be obtained by processing back the output of a process. There are two feedback loops –internal and external. The former loop is the one in which results of the tests are fed back to the preliminary design stage. The latter one occurs after the final product resulted from the design used in the market.

**Idea generation and conceptualization (Dieter et. al., 2000)**

Winnowing machine is based on air velocity which drives away the unwanted matter before storing rice grain, so that farmers can store their rice grain for future use or sell in the market (Dieter, 2000). There are two ways of obtaining air velocity –naturally and from the use of electricity. Naturally obtaining velocity entirely depends on natural force and farmers have to wait until the air force is enough to screen the rice grain. Next idea is to use any fan, blower, and motor with fan to get the enough air velocity for the rice grain screening purpose. Figure 6 shows an objective tree for designing winnowing machine.

**Concept 1**

It consists of hopper, natural air concentrator, frame, inner separator and outlet for screened rice and outlet for unwanted matter like small straw, grass etc. Rice grain which is to be winnowed is passed in through hopper hole into the screening chamber. By air velocity inside the screening chamber, lighter particles of husk, straw or other are blown away through husk outlet and screened rice grains are collected through the grain outlet. As the air inlet portion is horizontally wide, it takes huge space and is difficult to transport. Unlike the former one, it consists of electric motor (prime motor) or blower for air velocity. Due to this it consumes high electricity, it takes huge space and it is difficult to transport (Figure 7).

**Concept 2**

Unlike the concept 1, it consists of electric motor (prime motor) or blower for air velocity. Due to this it consumes high electricity and is heavy weight that makes transportation difficult (Figure 8).

**Concept 3**

This model also consists of hopper, frame, inner separator, exhaust fan for air velocity, current regulator and separate outlet for screened rice and unwanted matter. The main difference with concept 1 is that this elongates vertically for air velocity due to which it consumes comparatively less space (Figure 9).

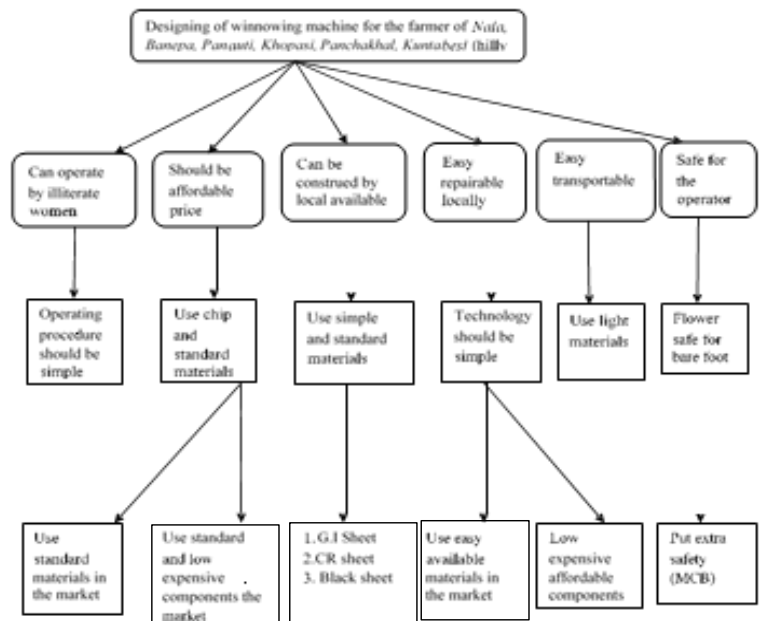

Figure 6. An objective tree for designing winnowing machine.

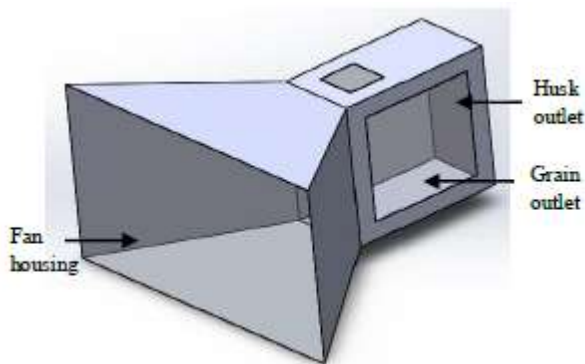

Figure 7. Concept 1.

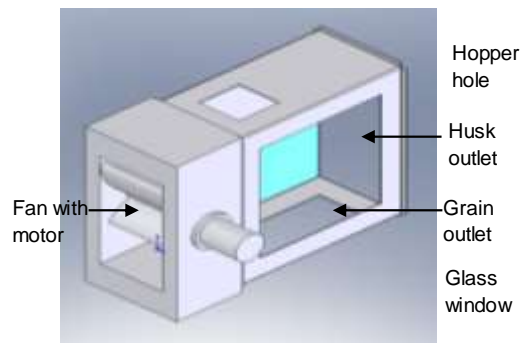

Figure 9: Concept 3

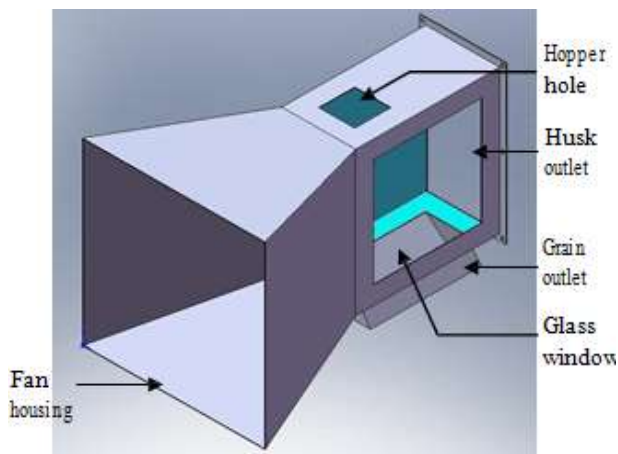

Figure 8. Concept 2

**Concept 4**

This concept consists of camera, conveyor, robotic arm or system and uses Neural Network technology. Rice grain is loaded on a conveyor belt which passes through a set of sensors that measures three properties of the rice grain, shape, texture and weight. These outputs will then be input to a neural network which functions to decide the kind of grain on the conveyor so that required rice grain can be directed to the correct storage bin. By referencing these three characteristics it separates required grain and unwanted matters in separate bins with high precision (Figure 10).

**Screening of ideas**

Out of these four concepts, concept 3 is better one than other. In this concept, rice grain is poured into the hopper. Control slider provide adequate amount of rice grain to flow into the screening chamber where incoming rice grain is impinged by the air force and the lighter matter like straw, grass, leaves and seeds, and

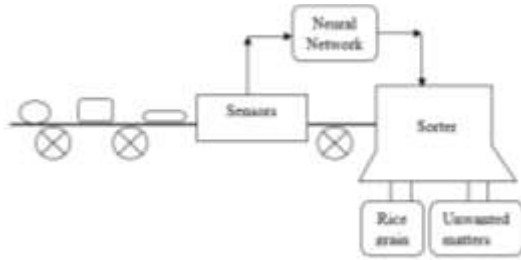

**Figure 10.** Neural network technology used in sorting rice grain with unwanted materials.

**Table 4.** Weighted factor and its score.

Weight analysis	Points
Major difference	3
Medium difference	2
Minor difference	1

whereas the screened rice is collected through the grain outlet.

### Evaluation phase

During the evaluation phase, alternative ideas were refined and analyzed with a view to ascertain if each one could achieve the intended functions or not. This was conducted in two stages:

**First phase:** All alternatives were thoroughly examined and elimination was done on the basis of quality, reliability or other basic reasons

**Second phase:** Critical analysis was done on the selected alternatives and further discussion was done with concerned personnel for viability and practicality of production. The ideas were, then, further short-listed and assigned for feasibility ranking matrix. Matousek (1974) suggested the following design criteria to test the ideas.

- A. Function
- B. Cost
- C. Energy consumption
- D. Material availability
- E. Compactness

Each of above criterion was given a weighted factor and compared with others. Depending on their relative importance, three categories were formed, that is, major, medium, and minor with individual score of 3, 2 and 1 assigned to each levels respectively. The details are as shown in Table 4:

### Paired comparison

In Table 5, A and D are closely connected with the weighting factor 3. Weight for each criterion is as follows:

- A. Function: 6
- B. Cost: 3
- C. Energy consumption: 2
- D. Material availability: 4
- E. Compactness: 1

Design alternative 3 is taken for the evaluation with the other design alternatives. Concept 3 has been given the 3 points for its best primary selection. Alternative design concepts are:

- Concept 1
- Concept 2
- Concept 3
- Concept 4

Feasibility ranking design concept 3 with other alternatives differences on cost are as shown in Table 6.

### Recommendation from the pair comparison

1. Design concept 3 is suitable for the given engineering problem
2. Concept 2 is also competitive with the concept 3 but concept three required more engineering calculation for the fan design so concept 3 is the best among all other alternatives.

### Preliminary product design specification

#### Product title

Winnowing machine (Dieter, 2000)

#### Purpose

To perform winnowing operation for rice grain

#### Special features

1. Quick operation of winnowing process.
2. Easy to operate.
3. Simple function.

#### Competition

There is no such machine available in Nepali market. In the foreign countries, winnowing process is integrated with husking machine or combine harvesting machine.

#### Need for the product

To reduce the woman labor incurred in the winnowing process during harvesting time, it is felt the requirement of winnowing machine which makes less effort of women labor. At the same time, they can spend their time in other income generating activity or to cure for their children. Preliminary survey showed that the product is affordable for the farmer with low income too.

#### Price

The expected cost of the winnowing machine is NRs. 20,000/- per unit including manufacturing cost of NRs. 3,000/-.

#### Functional performance

1. Separate rice grain from unwanted matters such as grass leaves, straw etc.
2. Low electricity consumption.

**Table 5.** Paired comparisons among alternatives

A	B	C	D	E	Score
A	A2	A2	D1	A2	A = 6
*	B	B1	D2	B3	B = 3
*	*	C	D1	C2	C = 2
*	*	*	D	E1	D = 4
*	*	*	*	E	E = 1

**Table 6.** Feasibility ranking.

Weight age	A	B	C	D	E	Score	Rank
Design ideas	6	3	2	4	1		
a	1	-2	0	1	-3	1	II
b	6	-6	0	4	-3		
	1	-2	-3	1	1	2	III
d	6	-6	-6	4	4		
	1	-3	-2	-3	1	-18	IV
	6	-9	-4	-12	1		

3. Less time consuming for same process.
4. Easy operation and adjusting procedure.
5. Light in weight.

#### Physical requirement

1. Expected size 1.35 m x 1.75 m x 0.5 m.
2. Approximate weight 35 kg.
3. Rectangular shape with slight streamline and physical looks like nozzle and glass window is provided for the tuning, winnowing process for the operator.
4. Frame is silver white color and rest of the body is sky blue color.

#### Materials

Winnowing machine is fabricated by using following materials:

1. Square pipe.
2. Black sheet.
3. GI sheet.
4. MS flat strip.
5. Transparent glass.
6. Nut and bolts.
6. Gasket material.

#### Service environment

It can perform work from 0 to 45°C in human comfortable humidity.

#### Life cycle issues

It depends upon the incorporated fan life cycle.

#### Constraints

1. Machine should not be used inside the room.

2. Machine should not operate during wet condition and operator hands should not be wet as well.

3. Machine is specially designed for separating rice and other unwanted matters which has substantially lower in weight, shape and density. The winnowing won't be able to separate stone and other higher weight and density matter if present in the rice heave

#### Detailed design of winnowing machine

The associate parts and components along with the functions and characteristics are as follows:

#### Hopper

It has two ends –wider opening for pouring grains and smaller opening for passing of grain to the screening chamber through grain regulator. The wider opening was made 45° conical shape to accommodate easy gravity slide of grains to the screening chamber. It should be capable enough to withstand load of 25 kg of rice grain without collapsing.

#### Fan (exhaust fan)

Fan should be driven with single phase 220/240 V and should have following features:

1. RPM 1400
2. Sweep: 300 mm
3. Inputs: 180 W
4. Amps: 0.32
5. Frequency: 50 Hz
6. Class: B type

It provides enough driving force to drive away the straws, grass leaves and other unwanted matters that are mixed with rice grains.



**Table 7.** Technical specification.

Length	1337 mm
Width	500 mm
Height	1370 mm
Power requirement	180 W, 220 V, 1400 rpm, electromotor
Fan	Axial fan with 4 blades
Fan sweep	300 mm
Fan holder size	495 mm × 250 mm × 495 mm
Ampere	0.32
Number of cascades	4
Frame	Single 20 mm × 20 mm × 4 mm square pipe frame
Glass window size	300 mm × 300 mm
Hopper capacity	25 kg
Grain flow regulator size	100 mm × 100 mm
Regulator plate	120 mm × 210 mm
Control box	Thyrister controlled regulator with 5 amps MCB

**Current regulator**

It controls the speed of fan according to the requirements.

**Frame**

It provides enough strength to support the whole assembly including 25 kg weight of the rice grain which is to be screened. It accommodates the inner parts for separating grain and the outlet for the lighter materials.

**Covering**

It is air-tight and is necessary for the screening chamber where it should enclose the separating chamber and fan housing.

**Separating chamber**

It separates the screened grain and other unwanted matters like leaves, straws, seeds etc.

**Handle**

It provides necessary strength to the whole system during transportation.

**Product performance and assembly**

Since the product is targeted to the farmers, its construction should be easy to be performed at local level with ease in assembling and disassembling whenever required. Keeping this view in mind, this product has easy assembling and disassembling techniques during manufacturing and is user friendly too.

1. Current regulator and the fan are easily available and during the manufacturing process, support is provided for the fan. Hopper housing can be constructed according to the size of the fan and hopper housing respectively. For the fan separate housing is

constructed which ensures the easy assemblage of fan into the fan housing.

2. The construction of separating chamber is made easier with inclination for grain outlet as 30° and husk outlet as 45° that can be performed easily by manufacturer.

3. The hopper rest on the screening chamber which is tied with four screws only. So, it can be performed by any local manufacturer without difficulty. Also, the structure of support is simple and can be made in cutting and welding of mild steel square pipe.

4. Handle is common term for every manufacturer. It is 90° bend twice structures weld to mild steel frame.

5. Noise: Every product noise level should be less than 70 db (human comfort). In this product, noise producing part is basically due to dropping and striking sound of rice grains and sound produced by electric fan which is below 30 db.

Wear resistance characteristic: To ensure long life, reliability and desired performance, the wear resistance characteristics of selected materials should be well noted and considered. For this purpose, the frame is painted silvery color and rest by blue paints.

**Final design and fabrication specification**

On the basis of detailed design, final design for the fabrication and technical specification were prepared as shown in Table 7.

**Practical observation**

The winnowing machine was built on the basis of the design specification and manufacturing drawing in the local workshop. We made 25×25 mm graph on the walls of the screening chamber so that we can read the grain flow path. Several trials and experiments were conducted on the winnowing machine to enhance its productivity. The trials varied from each other by changing the structure inside the chamber like by introducing the concept of cascading, inclined plane etc (Figure 11).

**First trial**

For the pilot test, 18 kg of rice grain and 1 kg of 20 to 30% filled grain (immature grains) and husk were mixed thoroughly. The



Figure 11: Picture of winnowing machine

Table 8. First field trial.

S/N	Initial (kg)	Final (kg)	Diff.	Time taken (s)
Husk outlet	0	0.250	0.750	48
Grain outlet	0	18.750	0.750	

Table 9. Second field trial.

S/N	Outlet	Initial (kg)	Final (kg)	Diff	Time taken (s)	Current regulator position
1	Husk outlet	0	0.30	0.70	50	Maximum
	Grain outlet	0	18.70	0.70		
2	Husk outlet	0	0.20	0.80	54	Middle
	Grain outlet	0	18.80	0.80		
3	Husk outlet	0	0.15	0.85	58	One fourth
	Grain outlet	0	18.85	0.85		
4	Husk outlet	0	0.30	0.70	51	Maximum
	Grain outlet	0	18.70	0.70		

mixture was poured in the hopper. At 75% opening of the grain flow regulator, it was found that screening process took 48 s to be completed (Table 8). It was found that as the husk outlet was made dense by the particles and husk, the air flow was restricted partially and grain outlet velocity increases which reduced the capacity of screening process and hence, 750 gm of unwanted matter were also present in grain outlet.

#### Second trial

For this, cascade was introduced into the screening chamber for cascading the flow of grains. The screening process was found much better than the first one; however, same problem arose. This

was done four times at 75% opening of grain flow regulator with different velocity, still problem persists (Table 9). It was found that as the velocity of the air reduces, the efficiency of the screening process also get reduced.

#### Third trial

In this trial, inclined plane was fitted towards the husk outlet which reduced the flow in outlet and meanwhile also reduces grain outlet area. The grain regulator position was maintained at 75% for this trial too (Table 10). It was observed that screening process found was much better than second trial but 50 g of grain was deposited in the fan housing.

**Table 10.** Third field trial.

Outlet	Initial (kg)	Final (kg)	Diff.	Time taken (s)	Current regulator position
Husk outlet	0	0.73	0.27	50	Maximum
Grain outlet	0	18.27	0.27		

**Table 11.** Fourth field trial.

Outlet	Initial (kg)	Final (kg)	Diff.	Time taken (s)	Current regulator position
Husk outlet	0	0.75	0.25	52	Maximum
Grain outlet	0	18.25	0.25		

**Table 12.** Fifth field trial.

S/N	Outlet	Initial (kg)	Final (kg)	Diff	Time taken (s)	Current regulator position
1	Husk outlet	0	0.75	0.25	68	Maximum
	Grain outlet	0	18.25	0.25		
2	Husk outlet	0	0.76	0.24	70	Maximum
	Grain outlet	0	18.24	0.24		
3	Husk outlet	0	0.77	0.23	80	Maximum
	Grain outlet	0	18.23	0.23		
4	Husk outlet	0	0.75	0.25	65	Maximum
	Grain outlet	0	18.25	0.25		
5	Husk outlet	0	0.765	0.235	71	Maximum
	Grain outlet	0	18.235	0.235		

#### Fourth trial

In this trial, another inclined plane was introduced towards fan housing to prevent the flow of grain from screening chamber towards the housing. The grain regulator position was maintained at 50% for this trial (Table 11). This observation was found to be better than the previous trials. Inclined plane prevented the grains entering into the fan housing.

#### Fifth trial

At first, mixture (composition same as previous trials) was fed from the hopper. Cascade and inclined planes were fitted into the screening chamber maintaining the grain regulator at half opening position (Table 12). In this condition, air velocity found at husk outlet and grain outlets were 5.1 and 2 m/s respectively. The time of run of the experiment was measured by means of stopwatch. The whole mixture was winnowed in mean time of 70.8 s.

## RESULT AND DISCUSSION

MATLAB simulation was carried out for the rice grain movement inside the screening chamber taking the coefficient of drag 0.4, air velocity 8 m/s for 0.0324 mg (highest weight) and 0.0228 mg (mean weight) of rice grain. The result obtained from it was used to determine

the size of the screening chamber. The dimension of the chamber obtained was 0.4 m × 0.4 m × 0.2 m.

The above dimension of the chamber was used to design a model in the SolidWorks. The design was imported in ANSYS CFX and then simulation was carried out after performing series of operations –meshing, inserting boundary conditions and converging criteria. Figure 12 shows the result obtained from it which is the physical representation of winnowing of the rice husk mixture. The lighter husk material is blown away by the air current of the fan while the comparatively heavier rice material falls just below the hopper at certain offset. This further validated the data of the screening chamber obtained from MATLAB.

### Experimental Analysis

As the screen chamber dimension obtained from the MATLAB was further verified using ANSYS simulation, then, the research was focused on prototype building for the experimental analysis. Several trials were conducted to obtain the productivity of the machine. Figure 13 shows the photograph taken through the transparent glass window, showing the screening of the rice grain

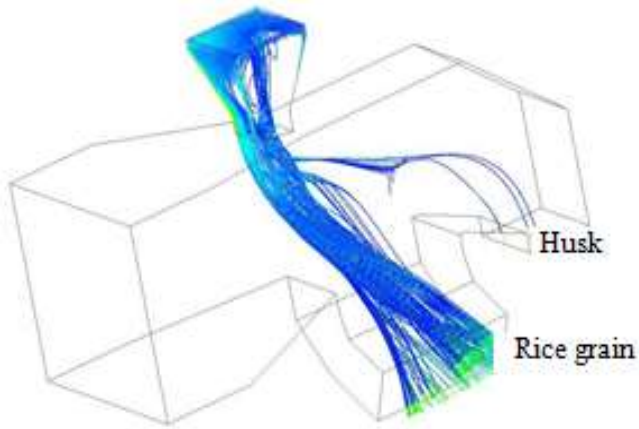

Figure 12. Separation of rice and husk through simulation.



Figure 13. Grain screening inside the screening chamber.

mixture inside the screening chamber.

The results obtained from each of the five trails are highlighted below.

1. During first trial, 0.750 kg (out of one kg) husk and immature grain was found in the grain outlet. It was concluded that as the husk outlet was made dense by the particles and husk, the air flow restricted partially and grain outlet velocity increases which causes husk forced through the grain outlet.
2. In second trial, cascade was fitted inside the screening chamber for facilitating the screening process and the result was found relatively better; however, 0.700 kg (out of one kg) husk was found in grain outlet and concluded that grain outlet should be reduced (Figure 14).
3. For the third trial, inclined plane was fitted toward the husk outlet. It was observed that 270 g of husk was found in grain outlet and some grains were present in fan



Figure 14. Vertical cascade fitted in the screening chamber.

housing too. It is because as the grain strikes the inclined plane, it gets rebounded towards the fan housing.

4. For the fourth trial, another inclined plane was introduced towards fan housing which prevented the rice grain entering into the fan housing and the result was found much better than the previous trials.

5. The fifth trial was conducted keeping the grain regulator in 50% opening condition and current regulator in maximum position. The productivity of the machine was found to be 966.10 kg/h.

The objectives behind placing the inclined plane inside the screening chamber are as follows:

1. To provide the nozzle effect for the husk and unwanted matters.
2. To reduce the grain outlet area so that it stopped flow of husk in the grain outlet.
3. To provide easy slide for the screened grains towards the grain outlet.

#### Machine productivity (separating capacity)

The time for the complete winnowing process was measured by means of stopwatch. The machine productivity was calculated as follows (El-Haddad et al., 2008):

$$P_m = \frac{W \times 3600}{t}$$

**Table 13.** Consumption of wattage for each different trials.

S/N	Voltage	Current	Watts	Total weight grain	Time taken (s)
1	220	0.32	45.056	19	68
2	210	0.32	43.008	19	70
3	220	0.32	45.056	19	80
4	200	0.32	40.96	19	65
5	220	0.32	45.056	19	71
Mean			43.8272	-	70.8

Where,  $P_m$  = Machine productivity (kg/s);  $W$  = Mass of sample (kg);  $t$  = Separating time (s).

For the test condition, Total mass of rice grains and mixture of husk = 19 kg; mean time taken for the winnowing process = 70.8 s; the productivity of the winnower obtained is 966.10 kg/h.

### Power consumption

This winnower machine uses 180 W Havells exhaust fan. It consumed 3.10 kWh for winnowing of 966.10 kg. The total consumed electric power under working load was calculated by the following equation (El-Haddad et al., 2008; Chancellor, 1981):

$$P = V \times I \times \cos\theta$$

Where,  $I$  = line current strength (Ampere);  $V$  = potential difference (Voltage), and  $\cos\theta$  = power factor = 0.64.

From Table 13, only 44 W electricity (on average) is consumed to winnow the rice grain mixture of 19 kg which is quite affordable in our context. Also, it takes only 71 sec (on average) to winnow the same amount which means it saves lots of time as comparison to manual winnowing process.

### Conclusion

Our aim was to use the engineering design concept and locally available standard materials to construct winnowing machine within the workshop. Commercial software like MATLAB, ANSYS were helpful in visualizing grain flow and determining the required chamber dimensions. Also, AutoCAD, Solid Works were helpful in designing the complete winnower machine. The productivity of the machine was found to be 966.10 kg/h while adopting the test modification for the fifth trial. The machine can be useful for the winnowing of rice grain during post harvesting process and for screening of white rice. After testing the winnowing machine, it has been concluded that the machine reduces human participation and effort for winnowing and hence the spare time can be utilized for other socio-economic purposes. Farmers can take advantage of this machine as good

winnowing process and less moisture content rice can be stored for longer periods.

The further recommendations in order to improve the machine are:

1. As the total approximate weight of this machine is 36 kg, fan cover can be made using wire mesh which reduces about 7 kg of total weight.
2. For the design simplicity, external covering can be made directly on the structure frame instead of making on screening chamber and fan housing assembly separately.
3. Hopper post can be made in such a way that its base should rest on the structure frame.
4. Grain outlet and husk outlet area should be made in such a way that it is approximately 160 mm long and 100 mm wide for the grain outlet and 200 mm long and 200 mm wide for husk outlet.
5. Only three cascades suitable for the cascade flow of the rice grain instead of four cascades.
6. Dusk arrester can be constructed on the bend of the husk outlet in such a way that it does not block the husk flow but arrest dust instead of spreading it on the environment.
6. Since the machine remains idle for 11 months, further research can be done for winnowing other crops by this machine.

### Conflicts of Interests

The authors have not declared any conflict of interests.

### ACKNOWLEDGMENT

The authors are very much thankful to Department of Mechanical Engineering of Kathmandu University for providing us the opportunity to carry out this research. We would also like to thank the staffs of Mechanical Engineering and Electrical Engineering department for their help during the fabrication of the winnowing process.

### REFERENCES

- Accetta K, Fellinger R, Goncalves PL, Musselwhite S, Pelt WPV (2013). "Current Research in Egyptology 2013," in Proceedings of the

- Fourteen Annual Symposium, United Kingdom.
- Aurora (2012). Adventuring on Planet Aurora, 13 May 2012. (Online). Available: [http://aurorakushner.com/wp-content/uploads/2011/10/dscn0905-e1319110605631\\_225x300.jpg](http://aurorakushner.com/wp-content/uploads/2011/10/dscn0905-e1319110605631_225x300.jpg). (Accessed 21 August 2016).
- Bassett N, Brower M, Michel S, Shinew M (2005). "Golf Ball Projectile Motion", EGR 312: Dynamics, 11 November.
- Chancellor WJ (1981). "Substituting information for energy in agriculture," Trans. ASAE Paper No. 0001- 2351.
- Dieter GE (2000). Engineering Design, New Delhi: McGraw- Hill Publishing Company Limited.
- El-Haddad WZ, Sayed-Ahmed IF, Gomaa RB (2008). "Modification of foreign threshing chamber to suit separating green peas crop," in The 15th. Annual Conference of the Misr Society of Ag. Eng. 12-13 March, 2008.
- Jang C, Kahn N, Langlois L, Liu R, Montanaro G (2014). "Design of a Winnowing Machine for West African Rice Farmers," Department of Bioresource Engineering, McGill University.
- Kelvin L et. al (2004). Golf Ball Projectile Motion Project.
- Manandhar GB, Adhikary SK, Sah G (2009). "Sustainable agriculture development and practices in Nepal,". National Agricultural Research Institute (NARI), Nepal Agricultural Research Council (NARC), Khumaltar, Lalitpur, Nepal. Last accessed on, 2.
- Matousek R (1974). Engineering Design, London: Blakie and sons limited, 1974.
- Meija DJ (2003). An overview of rice post-harvest technology: use of small metallic silos for minimizing losses. Rome, Italy: FAO.
- Muhammad US, Abubakar LG, Isiaka M, Davies RM (2013). "Design and evaluation of a cleaning machine," Applied Science Reports, PSCI Publications.
- Peirson B (2007). Analysis of Golf Ball Motion.
- Tomomi U, Nauruse M (2008). "Two-dimensional Vortex Simulation of Particulate Airflow Induced by Free Falling Particles.
- Tovar AA (2009). Air Drag Mathematics Reference Guide, 13 November, 2009.