

Review

Use of a simple abrasive-wear resistance test device to assess the suitability of selected hardwoods for wood flooring

Elisha Ncube

Department of Forest and Wood Science, University of Stellenbosch, Private Bag X1, Matieland 7602, South Africa.

Accepted 21 February, 2008

Indigenous hardwoods off-cuts generated by most mobile sawmills are usually discarded resulting in under utilisation of timber and reduction of profit margins. The traditional indigenous species used in wood flooring have poor regeneration and slow growth thus cannot indefinitely sustain fast harvesting rates. Equipment required to assess the suitability of wood for specific applications is not readily available in Zimbabwe, so a simple abrasive-wear resistance test device was used as an alternative. The device can be constructed in any wood technology laboratory equipped with basic machine tools. Hardness and abrasive-wear resistance tests were performed on the radial and tangential faces of selected hardwoods to assess their performance in wood flooring. The results showed slightly higher hardness on the tangential face in poplar and mahogany only and that hardness increased with wood density. This study showed that neither the hardness value nor wood density can sufficiently explain increased abrasive-wear resistance because this is controlled by certain compounds found in wood cavities. However, ranking of selected hardwood species into different wood flooring traffic classes was similar for hardness values and abrasive-wear resistance indices. This illustrated the potential for using abrasive-wear resistance tests device as an alternative technique. Successful use of this device may assist in the identification of alternative species, relieve pressure on commercial indigenous species and facilitate collection of performance data and other wood species suitable for wood flooring.

Key words: Hardness value, abrasion-wear resistance index, basic wood density, wood flooring.

INTRODUCTION

Several mobile saw mills convert indigenous hardwoods into boards for the furniture industry. The timber is harvested from state land through concessions managed by the Forestry Commission of Zimbabwe. The species converted are mukwa (*Pterocarpus angolensis*), pod mahogany (*Azelia quanzensis*), teak (*Baikia plurijuga*), m'chibi (*Guirbourtia coleosperm*), panga-panga (*Melletia stulmannii*) and mpapama (*Entandrophgma caudatum*). Traditionally, manufacturers of wood flooring use mukwa, m'chibi, and teak (Saruchera, 2006; Ferris, 1956), but these species are not readily available and it is important to manage tropical timbers on a sustainable basis (Anon, 1999; Anon, 1974).

The recovery in these sawmills is low due to natural defects inherent in the timber and the need to produce large standard boards for the furniture industry. It has been observed that off-cuts generated are not being utilised. In a sample of five sawmills with a daily production of 4.5 m³ per 9 h shift, at 40% recovery, the off-cuts generated translate to 1 074.5 m³/mill at 239-annual working days (Gwete, 2000). These off-cuts have potential for use in wood flooring especially wood mosaic/parquets flooring.

The behaviour of wood commonly used for flooring can be predicted with some accuracy, but this is not true for other species of wood and various types of flooring material. The standard equipment of testing wood properties is expensive. The rigors wood flooring is subjected to in service can be simulated and tested for abrasion resistance (Kollman and Wilfred, 1968). Unlike in hardness tests, the effects

*Corresponding author. E-mail: encube@sun.ac.za.

Table 1. Classification of hardwoods used for wood flooring at 12% MC (Anon, 1974; Goldsmith and Carter, 1981).

Species	Traffic	Janka hardness (kg)	Density (kg/m ³)
Teak	1, 2, 3 & 4	1310.9	929.1
Pod mahogany	2, 3 & 4	721.29	769.5
Panga panga	2, 3 & 4	889.0	752.9
M'chibi	3 & 4	893.6	672.8
Mukwa	4	567.1	656.8
Mpapama	= =	= =	735

Table 2. Traffic classes at 12% M.C. (Anon, 1974).

Class	Type of traffic	Density (kg/m ³)
1. Very heavy	Exceptionally abrasive and heavy, mainly industrial (warehouses, mills and factories) where floors are subjected to heavy loads.	Above 913
2. Heavy	Mainly pedestrian with light loads as in public buildings (hospitals, schools, colleges, dance halls, stores and rail or bus station) with daily traffic of over 2000 people.	753 – 897
3. Moderate	Mainly pedestrian traffic where floors carry dispersed loads of not more than 2000 persons per day.	657 – 738
4. Light	Light pedestrian as in homes and small offices.	---

of wood species, plain or quarter sawn, moisture content, surface condition, presence of interlocked grain and artificial protection could be accounted in abrasive-wear resistance tests because the whole surface is abraded in a test.

Consequently, a simple test device that could indicate the abrasive-wear resistance index for wood could be of great value to training institutions in developing economies. This will facilitate utilisation of wood off-cuts to maximize profit margins and to relieve pressure on existing species, and assessment of alternative lesser-used wood species as flooring material.

Requirements for wood flooring material

Solid wood can be laid in strips, blocks or as parquets usually above 18 mm in thickness (Desch and Dinwoodie, 1996). The strips are oriented on the floor to display radial or tangential faces that are exposed to traffic. The advantage of wood flooring surface is not only aesthetic attractiveness in terms of colour, grain and figure, but in its good wearing properties such as abrasion resistance (Desch and Dinwoodie, 1996). The type of traffic, hardness value, density and linear shrinkage value determines the suitability of timber for flooring (Anon, 1974).

Abrasion resistance is an important property for assessing the suitability of wood especially in heavy traffic areas where continuous wax or other film is not applied (Anon, 1974). Very hard and abrasion resistant flooring is desirable under heavy industrial traffic (Findlay, 1975). Hardness is related to the strength of wood in abrasion and scratching with various objects, as well as to the

difficulty or ease of working with tools or machines (Tsoumis, 1991). This implies that hardness is an important reference property for various uses e.g. floors, furniture, sport items, pencils, etc.

In non-domestic wood flooring application, higher density timber is recommended, and a variety of hardwoods such as *Quercus* sp.(oak), *Acer* sp.(maple), *Chlorophora excelsa* (iroko) and *Entandrophragma cylindricum* (sapele) are suitable (Desch and Dinwoodie, 1996). Tables 1 and 2 give a summary of characteristics and classification of some of the wood species under consideration here.

Analysis of hardness test techniques

Hardness is defined as the ability of a body to resist deformation or entrance of a foreign body into its mass (Doyle and Walker, 1985; Tsoumis, 1991). Testing involves forcing a tool of known geometry into the wood in order to obtain a hardness value. Hardness can be specified as the ratio of the applied force to the size of the indentation (Doyle and Walker, 1985) or as the maximum force attained at recommended indentation.

The methods for measuring hardness are based on the geometry of the indenter. There are ball hardness, hardness modulus, cylindrical tools, cone hardness and wedge hardness (Doyle and Walker, 1985). With the exception of wedge hardness, values obtained using other methods are not easily comparable to each other and do not allow comparison with other materials. This is further complicated in that mechanical strength of isotropic materials is uniform unlike that of composite anisotropic

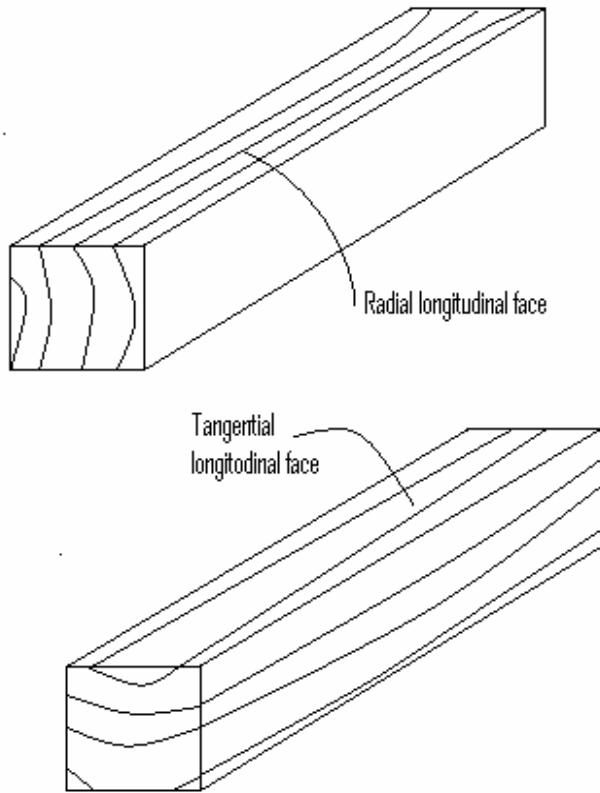

Figure 1. Radial and tangential face hardwood specimens (Drawing not to scale).

materials such as wood where strength parallel and perpendicular to grain is different (Desch and Dinwoodie, 1996).

Janka proposed and developed a modified Brinell hardness test for wood (Kollman and Wilfred, 1968; Lavers, 1983; Roberta, 1997). The Janka test is limited in that deep indentations formed create side-stresses which may cause splitting in high-density timber as a result of the effects of wood failure, friction, and cleavage. It is further contended that the irregular hardness across wood surface, the correlation of hardness to crushing strength, and the variety of hardness tests not all testing the resistance of the surface to penetration, indicate the lack of validity of hardness tests (Kollman and Wilfred, 1968).

MATERIALS AND METHODS

A repeatable test method using selected hardwoods was designed and implemented using blackwood (*Acacia melanoxylon*), mahogany (*Khaya sp.*) and poplar (*Populus sp.*) with reference to iroko (*Chlorophora excelsa*). Abrasive-wear resistance and hardness of timber in radial longitudinal face and tangential longitudinal face were determined to establish the viability of the proposed abrasion test equipment and to produce a cheaper alternative for identification of species suitable for wood flooring in very heavy (industrial), heavy, moderate and light load (domestic) applications.

Wood specimens preparation

Eighty clear specimens consisting of blackwood, mahogany, poplar and iroko were selected and machined to a standard size of 20 × 20 mm (cross-section) × 100 mm (long) to reduce the probability of splitting (Figure 1). The test specimens were of normal growth rate and density, free of knots and gums. The identity of the species was verified by means of a × 10 hands lens. To ensure even abrasion, the specimens were machined to the nearest 0.25 mm for the area to be abraded and 0.025 mm in thickness (taken from centre and near the corners). The test surface was kept free from any coating to prevent any interference with wear rate that could result in false wear resistance due to clogging of the abrader.

Sets of wood specimens for each species were prepared and coded. Iroko served as the reference specimen because it is a tropical species used in wood flooring. Mukwa is used as a reference species in Zimbabwe (Timberlake et al., 1999).

The test specimens were conditioned at 20°C and 65% relative humidity to a constant weight. Each specimen was weighed (W_w) immediately before the test using an electric balance (± 0.0001 g). After the test, 25 mm long sections were cut from each specimen and oven-dried at 105°C to a constant weight (W_o) to determine their moisture content (MC) (Equation 1). This was done after testing because drying could interfere with hardness characteristics.

$$MC = [(W_w - W_o) / W_o \times 100] \quad (1)$$

where W_o = Oven dry weight; W_w = Wet weight; MC = Moisture content.

Modified Janka hardness test

A Janka hardness tester with a modified, diameter 11.3 mm ball (projected area 1 cm²) was used to determine the hardness of specimens. One centralised penetration was made on the tangential and radial face by continuously applying the load at a rate of 6.6 mm/ min. The load at which the ball attained half its penetration was recorded as the hardness (kN) of the wood specimen.

Abrasive-wear resistance test

A device to stimulate wear produced in service was constructed and used to measure abrasion resistance of wood flooring surfaces on the basis of weight loss. A number 80 grit size abrasive was used. The weight loss was employed instead of thickness decrease because it precisely indicated the total amount of material abraded in each cycle as it can account for uneven wear in late-wood-earlywood transition regions where there is reaction wood and interlocked grains.

A modified abrasion wear resistance testing method was employed. A specimen was clamped to expose the 20 × 100 mm to the abrading medium that reciprocated at 9 stroke cycles per minute. The single abrading sheet was run in and used on each set of wood species specimens. The abrader was not changed as it was considered to be sufficiently durable to maintain consistent wear rate on few species of low to medium density. To minimise any effects of reduced efficiency of the abrader and bias, tests were carried out in random blocks of specimens from the four species.

A load approximately equivalent to the average traffic weight was superimposed on the test specimen. After 100 strokes, the specimen was removed and any dust or abrading material adhering to its surface was brushed off. The specimen was measured for weight loss to determine the amount of material abraded in each test cycle.

The procedure was repeated five times or until five points of weight loss per 100 revolutions plotted essentially as a straight line.

Table 3. Measurements of the density and hardness of four hardwood specimens [coefficient of variation (cov) and coefficient of determination (r^2)].

Species	Density (kg/m ³)	Number of specimens	Hardness (kN)		
			Radial face	Tangential face	Mean
Poplar	361.2	32	1.287	1.298	1.292
Cov	3.89%		10.49%	11.48%	7.41%
r^2			0.04%	45.5%	26.1%
Blackwood	621.7	21	4.612	5.444	5.028
cov	13.68%		32.33%	35.12%	32.28%
r^2			80.0%	79.6%	88.1%
Mahogany	602.4	19	4.175	4.640	4.408
cov	1.35%		6.61%	7.87%	6.63%
r^2			16.6%	64.7%	47.7%
Iroko	554.54	8	3.7	3.78	3.74
cov	2.37%		9.78%	8.44%	6.07%
r^2			4.3%	13.7%	18.1%

The slope of the line indicated the change in weight per set of abrasion strokes. The weight loss measurement at each data point was transformed into its logarithm. The slope (b) of the linear portion of the resulting semi-logarithmic plot indicating the rate of wear was computed using the least square linear regression technique (equation 2):

$$b := \frac{\left(\frac{\sum X_{1...5} \cdot \ln Y_{1...5}}{n} - \frac{\sum X_{1...5} \cdot \sum \ln Y_{1...5}}{n \cdot n} \right)}{\left[\frac{(\sum X_{1...5})^2}{n} \right] - \left[\frac{(\sum X_{1...5})}{n} \right]^2} \quad (2)$$

where $X_{1...5}$ = Weight loss interval; $\ln Y_{1...5}$ = Weight loss logarithm; n = Sample size.

The inverse of the slope gave the abrasive-wear resistance index. The higher the wear resistance index the higher was the abrasive-wear resistance and vice-versa.

RESULTS AND DISCUSSION

The relationship between wood density with either hardness and abrasive-wear resistance was established by the Pearson's product moment correlation coefficient (r). The relationship between the two values of correlation coefficient is approximately a square law relationship referred to as coefficient of determination (r^2).

Basic density and hardness

The moisture content of specimens ranged between 9 and 13%. These results agreed with the expected equilibrium moisture content for wood conditioned at 20°C and 65% relative humidity. The results for hardness tests and measurement of basic density are summarised in (Table 3). The variation in the density and hardness values of wood specimens was very small except for the slight increased dispersion in blackwood due to the structural variability of these wood specimens (Table 3). With

the exception of blackwood, hardness was higher on the tangential faces, but a closer inspection indicates that the difference is negligible. This tendency for increased hardness on the tangential face is problematic because it coincides with the radial direction where movement is least. The movement of timber is smaller in the radial direction so horizontal positioning of wood in this direction minimises movement.

Analysis of results using the coefficient of determination (r^2) show that lower wood densities have a very low influence on the hardness value especially on the radial face (Table 3). These results indicate that the capacity for predicting the hardness value of wood using its density increases with increasing density. The potential for density as a tool for predicting the hardness of wood is further explored in Table 4.

The power law gave the best description of the relationship between density of hardwood used in this study and their hardness values (Table 4). It is clear that the hardness values of the hardwood species increased with the density in a non-linear manner. It has been confirmed that the existence of a close correlation between the strength of wood and its density and that it was possible to estimate hardness without even knowing the species (Haygreen and Bowyer, 1996).

The results here show two distinct levels of relationships. The lower density species also had lower correlation with hardness and the capability of density as a predictor of hardness improved with increasing density. It is postulated that these changes are related to the structural variables of wood such as porosity (diffuse or ring), the presence of rays, cell wall alignment and thickness because these characteristics change with density resulting in the alteration of the hardness of wood.

Abrasive-wear resistance

The coefficient of variation in abrasive-wear resistance

Table 4. Ranking of wood flooring materials into traffic classes.

Traffic class	Density (kg/m ³)	Wear resistance index	Hardness (kg)
1. Very heavy	913+	--	teak
2. Heavy	753 -897	--	pod mahogany panga-pang
3. Moderate	657 -738	--	m'chibi mpapama mukwa
4. Light	621.7 ¹ 602.4 ¹ 554.5 ¹	blackwood iroko	blackwood mahogany iroko
Unclassified	361.2 ¹	poplar	poplar

¹Density values obtained from this study.

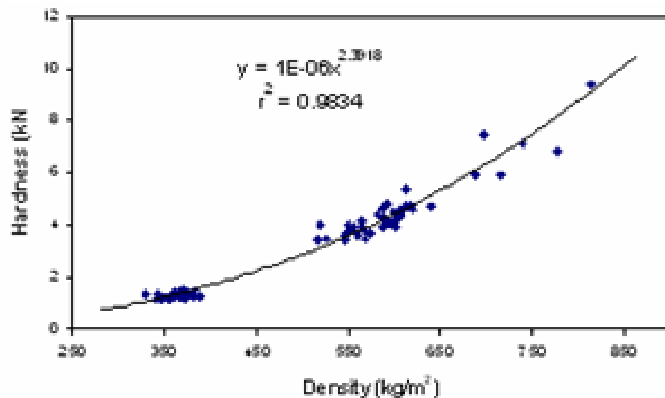

Figure 2. Relationship between the density and hardness of various wood species.

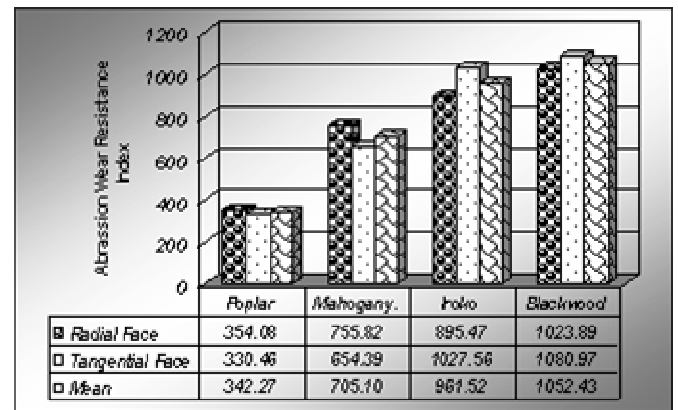

Figure 3. Abrasive-wear resistances of hardwoods on radial and tangential faces.

test increased from 6.8 to 22.6% with the decreasing number of specimens. The slight increase in variability is acceptable since this work is for exploratory purposes, but when implementing a full-scale assessment of species for suitability in wood flooring, a minimum sample size of 30 specimens is recommended by statisticians. A summary of the results for abrasive-wear resistance of hardwood species tested on radial faces and tangential faces is given in Figure 3. The figure shows a higher radial face abrasive-wear resistance in poplar and mahogany specimens and vice-verse on the other two species. The results also show that the increase in abrasive-wear resistance was not entirely associated with the density of wood. Despite having a lower density than mahogany, iroko offered higher abrasive-wear resistance. Similarly, Youngquist and Munthe (1956) also found some inconsistencies in *Fraxinus spp* (Ash), *Fagus spp.* (Beech) and *Betula spp.* (Birch) that exhibited less abrasive-wear resistance than wood species of lower density such as *Populus spp.* The hardwood species used in this study were classified according to their abrasive-wear resistance index, density and hardness values (Table 4).

Additional data was obtained from the literature (Anon, 1974). Mukwa, mpapama and m'chibi qualified for moderate traffic, pod mahogany and panga-panga for heavy loads while teak was classified for industrial applications (very heavy loads). The classifications of the remaining hardwood species are discussed below.

It is apparent from Figures 2 and 3 that the influence of wood density on its abrasive-wear resistance is limited. The ranking of species according to their hardness values and abrasive-wear resistance index in Table 4 show an exchange of positions between iroko and mahogany. Cavities filled with stone deposits have been observed on the sawn surface of iroko (Wilson and White, 1986). It is likely that various degrees of silicon (i.e. stone) content in iroko enhance abrasive-wear resistance, but has negligible influence on wood density. Similarly, low abrasive-wear resistance of Australian jarrah is attributed to the presence of brittle (abrasive) resinous substances, and high resistance of Burma teak has been linked to the presence of oily extractives (Kollman and Wilfred, 1968). Specimens of *Populus sp.* were unclassified indicating that similar species may not be suitable for wood flooring

material (Table 4).

Conclusion

Although the results were not definitive, they were tendencies for increased hardness on the tangential faces and blackwood only. The tendency for increased hardness in radial face coincides with radial direction where movement is minimal which illustrates the importance of using wood species with small movement. Laying wood flooring with radial direction in the horizontal plane could minimise movement.

The coefficient of determination shows that lower wood densities have a very low influence on the hardness value especially on the radial face. These results indicate that the ability to accurately predict the hardness of a specific wood species using its density increases with density. It is thought that variables such as void volume, i.e. wood porosity, cell wall thickness and growth defects such as interlocked grains have a positive contribution to both the density and hardness of timber. The results here corroborates previous studies as they showed that improved wear resistance in wood is brought about by disposition of certain compounds in wood cavities and wood density plays a smaller role.

The results here show that neither the hardness value nor the density of wood sufficiently indicates the degree of abrasive-wear resistance. However, the results illustrate the potential of using the abrasive-wear resistance test in a full-scale assessment to establish the suitability of lesser-used indigenous hardwoods for wood flooring to relieve pressure from commercial indigenous hardwood species. Reliance on published data is limited in that lesser-used species have not been extensively studied to account for subtle property differences attributed to wood variability.

ACKNOWLEDGEMENTS

I acknowledge that the experimental work reported was undertaken using facilities and wood specimens provided by the Forest Products Research Centre, Buckinghamshire Chilterns University, UK, and that Mr Brain Mathews, Mr Jarvis Sawyer and Dr Hugh Mansfield Williams assisted in the fabrication of the abrasive-wear resistance test device.

REFERENCES

- Anon (1974). Wood mosaic floors for a lifetime: Timber technical guide. South African Lumber Millers Association.
- Anon (1999). Pulp and Paper Information Sheet
- Desch HE, Dinwoodie JM (1996). Timber Structure, Properties, Conversion and Use. The MacMillan Press Ltd, London.
- Doyle J, Walker JCF (1985). Indentation Hardness of Wood. *Wood and fibre Science* 17(3): 369-376.
- Ferris NS (1956). Know your Rhodesia Know Nyasaland. Rhodesia Printing Company Ltd, Salisbury.
- Findlay WPK (1975) Timber properties and uses. Granada Publishing Ltd, London.
- Goldsmith B, Carter DT (1981). The Indigenous Timbers of Zimbabwe; The Bulletin of Forestry Research No. 9.
- Gwete C (2000). Forest Industries Training Centre: August 2000 Report.
- Haygreen JG, Bowyer JL (1996). Forest Products and Wood Sciences: An introduction. Iowa State University Press, Iowa.
- Kollman FFP, Wilfred AC (1968). Principles of Wood Science and Technology 1 Solid Wood. Springer-Verlag, Berlin.
- Lavers GM (1983). The Strength properties of timber. HMSO, London.
- Roberta AS (eds) (1997) Annual Book of ASTM standards: Standard Methods of Testing Small Clear Specimens of Timber. D American Society for Testing and Materials (ASTM): West Conshohocken. 4(10):143-94.
- Saruchera M (2006). State of the environment Reporting programmes for Zambezi Basin: Forests shrinking in most basin states. *SOEPROZ*. Available from: www.sardc.net/imersca/zambezi/ZNews-letter/issue1of2/forest.htm. [Accessed 19 March 2006]
- Timberlake J, Fagg C, Barnes R (1999). Field guide to the Acacias of Zimbabwe, CBC Publishing, Harare.
- Tsoumis G (1991). Science and Technology of Wood Structure, Properties. Utilisation. Chapman and Hall, New York.
- Wilson K, White DJB (1986). The Anatomy of Wood: its Diversity and Variability. Stobart and Son Ltd, London.
- Youngquist WG, Munthe BP (1956). The Abrasive Resistance of Wood as determined with the U. S. Navy Wear-test Machine. Forest Products Laboratory-Forest Service U. S. Department of Agriculture and the University of Wisconsin.